

සියලු ම හිමිකම් ඇවිරිණි/முழுப் பதப்பிழைப்புடையது/All Rights Reserved]

ශ්‍රී ලංකා විභාග දෙපාර්තමේන්තුව ශ්‍රී ලංකා විභාග දෙපාර්තමේන්තුව ශ්‍රී ලංකා විභාග දෙපාර්තමේන්තුව ශ්‍රී ලංකා විභාග දෙපාර්තමේන්තුව ශ්‍රී ලංකා විභාග දෙපාර්තමේන්තුව  
 இலங்கைப் பரீட்சைத் திணைக்களம், Sri Lanka Department of Examinations, Sri Lanka  
 Department of Examinations, Sri Lanka

අධ්‍යයන පොදු සහතික පත්‍ර (උසස් පෙළ) විභාගය, 2015 අගෝස්තු  
 கல்விப் பொதுத் தராதரப் பத்திர (உயர் தர)ப் பரீட்சை, 2015 ஓகஸ்ட்  
 General Certificate of Education (Adv. Level) Examination, August 2015

කෘෂි තාක්ෂණවේදය I  
 விவசாயத் தொழினுட்பவியல் I  
 Agro Technology I

18 E I

පැය දෙකයි  
 இரண்டு மணித்தியாலம்  
 Two hours

### Instructions:

- \* Answer all questions.
- \* Write your **Index Number** in the space provided in the answer sheet.
- \* Instructions are given on the back of the answer sheet. Follow those carefully.
- \* In each of the questions 1 to 50, pick one of the alternatives from (1), (2), (3), (4), (5) which is **correct or most appropriate** and mark your response on the answer sheet with a cross (x) on the number of the correct option in accordance with the instructions given on the back of the answer sheet.

1. Select the correct statement from the following in relation to the use of appropriate technology in a production system.
  - (1) Increase cost of production and labour use efficiency.
  - (2) Increase productivity and production efficiency.
  - (3) Ensure use of less labour and more machinery.
  - (4) Extends shelf-life and improve quality of the product.
  - (5) Improves appearance and texture of the product.
2. Following are some techniques used in banking.
 

A - Money transfer	B - Internet banking
C - Credit card	D - Debit card

Of the above, new technologies used in buying and selling of commodities in successful business management are

  - (1) A, B and C only.
  - (2) A, B and D only.
  - (3) A, C and D only.
  - (4) B, C and D only.
  - (5) All A, B, C and D.
3. A chronic disease condition which is **not** directly associated with over-nutrition, is
  - (1) cancer.
  - (2) heart attack.
  - (3) stroke.
  - (4) diabetes.
  - (5) osteoporosis.
4. The body mass index (BMI) of a person is best explained as the
 

(1) $\frac{\text{body mass (kg)}}{\text{body height (cm)}}$	(2) $\frac{\text{body mass (kg)}}{\text{body height}^2 \text{ (m)}}$
(3) $\frac{\text{body mass}^2 \text{ (kg)}}{\text{body height (m)}}$	(4) $\frac{\text{body mass}^2 \text{ (kg)}}{\text{body height (cm)}}$
(5) $\frac{\text{body mass (kg)}}{\text{body height}^2 \text{ (cm)}}$	
5. Following two statements are based on the biochemical spoilage of food.
 

A - Enzymatic reactions may lead to spoilage of food.

B - Browning of food can be explained as an enzymatic reaction.

Of the above,

  - (1) only A is correct.
  - (2) only B is correct.
  - (3) both A and B are correct.
  - (4) A is correct and it is further explained by B.
  - (5) B is correct and it is further explained by A.

6. The most common microorganism, which is responsible for the spoilage of meat, is  
 (1) *Clostridium botulinum*. (2) *Aspergillus flavus*.  
 (3) *Aspergillus oryzae*. (4) *Lactobacillus bulgaricus*.  
 (5) *Lactobacillus thermophilus*.
7. A student listed the following as the processes affecting food security of a country.  
 A - Increasing food production B - Reducing post-harvest losses  
 C - Food diversification D - Food preservation  
 Of the above, the processes directly contribute to food security are,  
 (1) A and B only. (2) A and C only  
 (3) A, B and C only. (4) B, C and D only.  
 (5) All A, B, C and D.
8. Following statements are based on the agroclimatic regions, great soil groups and mean annual rainfall of Sri Lanka.  
 A - 14 great soil groups have been identified in Sri Lanka.  
 B - Based on the distribution of rainfall, Sri Lanka has been divided into three agro-climatic zones.  
 C - The dry zone of Sri Lanka receives a mean annual rainfall less than 1,750 mm with a distinct dry season from May to September.  
 Of the above, correct statement(s) is/are  
 (1) A only. (2) B only.  
 (3) A and B only. (4) A and C only.  
 (5) B and C only.
9. The elevation of the mid country of Sri Lanka is  
 (1) 0 - 50 m above sea level. (2) 50 - 100 m above sea level.  
 (3) 100 - 300 m above sea level. (4) 300 - 900 m above sea level.  
 (5) 900 - 1 500 m above sea level.

● Use the given figure to answer question No. 10.

10. The plant propagation technique shown in the figure is  
 (1) budding.  
 (2) side grafting.  
 (3) veneer grafting.  
 (4) in-arching.  
 (5) wedge grafting.



11. Parthenocarpy is best defined as  
 (1) artificially-induced production of fruits without seeds.  
 (2) natural or artificially-induced production of fruits without fertilization of ovules.  
 (3) growth and development of embryos occurring without fertilization.  
 (4) a sexual reproduction technique that produces fruits without seeds.  
 (5) an asexual reproduction technique through which seedless fruits are produced.
12. Select the correct statement from the following  
 (1) Insecticides are commonly used in Sri Lanka as seed treatments before planting.  
 (2) Roots of the leeks plant are used as material for vegetative propagation.  
 (3) Propagation by seeds will increase the biological diversity of the ecosystem.  
 (4) Vegetative propagation will increase the genetic diversity of the plant population.  
 (5) Captan is the chemical used to remove dormancy of crop seeds before planting.
13. Following are some parts of *Aegle marmelos* (Bael).  
 A - Thorns on the stem B - Roots  
 C - Leaves D - Fruits  
 E - Bark  
 Of the above, the part(s) not used for medicinal purpose is/are  
 (1) A only. (2) B only.  
 (3) A and E only. (4) C and E only.  
 (5) B, D and E only.

14. Select the incorrect statement about ginger.
- (1) It is used to treat vomiting. (2) It is used to treat abdominal pain.  
 (3) It is used to treat cough. (4) It is used to treat food poisoning.  
 (5) It is used to treat Asthma.
15. Consider the following diseases.
- A - worm diseases B - eye diseases  
 C - skin diseases D - heart diseases  
 E - kidney diseases
- Of the above, diseases treated by using plant parts of Murunga (*Moringa oleifera*) are
- (1) A, B, and C only. (2) A, B, and D only.  
 (3) A, C and E only. (4) B, C and D only.  
 (5) C, D and E only.
16. Ecosystem-Based Management (EBM) is a management approach that is used to integrate
- (1) economic, ecological and business goals.  
 (2) ecological, social and economic goals.  
 (3) ecological, social and agricultural goals.  
 (4) social, business and economic goals.  
 (5) agricultural, social and economic goals.
17. The main reason for storing perishables at low temperature is to
- (1) minimize moisture loss.  
 (2) increase the respiration of soft tissues.  
 (3) maintain the viability.  
 (4) minimize the microbial and physiological activities.  
 (5) improve the colour.
18. The presence of fungi in dried chilli is mainly due to
- (1) harvesting at immature stage. (2) improper drying conditions.  
 (3) storing at dry places. (4) storing in dark places.  
 (5) sun drying.
19. Following are three statements on biotechnology.
- A - Modern-day science is developed based on biotechnology.  
 B - Biotechnological applications are found in traditional practices.  
 C - Biotechnology is one of the important technologies developed recently.
- Of the above, the correct statement/s is/are
- (1) A only. (2) B only. (3) C only. (4) A and B only. (5) A and C only.
20. A potential good entrepreneur
- (1) is always prepared to take high risks.  
 (2) never take high risks.  
 (3) usually take risks and manage them carefully.  
 (4) tries to avoid risks and minimize losses.  
 (5) manages risks without external assistance.
21. Consider the following statements in relation to entrepreneurship.
- A - A good entrepreneur is flexible, independent and devoted to work.  
 B - The success of an entrepreneur depends on the initial investment.  
 C - Delegation of responsibilities to others exhibits the leadership of an entrepreneur.
- Of the above, the correct statement/s is/are
- (1) A only. (2) B only. (3) C only. (4) A and B only. (5) A and C only.
22. The pyramid represents the employees of different categories of a tea packaging business. The categories 'A' and 'B' would be
- (1) owner and director, respectively.  
 (2) director and assistant manager, respectively.  
 (3) assistant manager and supervisor, respectively.  
 (4) supervisor and foreman, respectively.  
 (5) senior supervisor and junior supervisor, respectively.

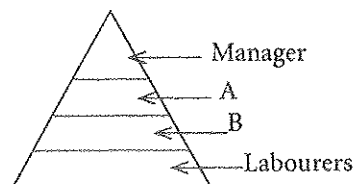

23. The information required to prepare a balance sheet of a small enterprise are
- (1) income and expenditure.
  - (2) income, expenditure and profit.
  - (3) capital investment and gross income.
  - (4) assets and liabilities.
  - (5) assets, liabilities and profit.
24. Wind direction is important during application of agrochemicals using a knapsack sprayer as it
- (1) reduces the droplet size and application rate.
  - (2) determines the direction of movement of the operator to minimize the risk.
  - (3) increases the dosage of the chemical applied.
  - (4) reduces the amount of chemicals applied on plants.
  - (5) does not support the use of liquids.
25. A limitation of the Sri Lankan type biogas digester is
- (1) low moisture content in biogas compared to other types of biogas digesters.
  - (2) that it is restricted only for the digestion of rice straw.
  - (3) that it requires skilled labour for construction.
  - (4) it stops the biogas production during refilling stage.
  - (5) it is more prone to gas leakage.
26. Select the correct statement in relation to use of bamboo for farm structures.
- (1) Not suitable as it has less strength than concrete.
  - (2) It can be considered as an appropriate technology if used for a correct purpose.
  - (3) May increase the cost, if it is used as a substitute for GI pipes.
  - (4) Not recommended as it degrades faster.
  - (5) Not promoted as it affects the environment.
27. The following implement is used,

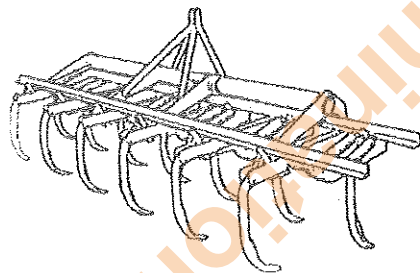

- (1) for breaking the hard pan of compacted soils.
  - (2) with a two-wheel tractor for land preparation.
  - (3) with a four-wheel tractor for primary land preparation in upland farming.
  - (4) with a four-wheel tractor for land preparation in low land farming.
  - (5) in plantations for inter-cultivation.
28. Following is a two-wheel tractor with an implement attached. The implement connected to the two wheel tractor is a

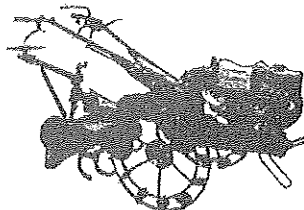

- (1) disk plough.
  - (2) rotovator.
  - (3) tine tiller.
  - (4) mold board plough.
  - (5) water pump.
29. With the decrease in the average size of soil particles
- (1) nutrient-holding capacity of the soil will decrease.
  - (2) infiltration will increase.
  - (3) water-holding capacity of the soil will increase.
  - (4) aeration will decrease.
  - (5) organic mater content will increase.

30. The ability of a soil to hold water is determined by
- (1) evaporation, transpiration, and sublimation.
  - (2) infiltration capacity, water-holding capacity and evaporative water loss.
  - (3) irrigation, infiltration and salinization.
  - (4) depth of soil, particle size and organic matter content.
  - (5) infiltration capacity, water-holding capacity and evaporative water loss.
31. Percolation losses are high in
- (1) soils with high organic matter.
  - (2) soils with high amount of clay.
  - (3) compact soils than loose soils.
  - (4) sandy soils.
  - (5) loamy soils.
32. Irrigation interval is increased
- (1) in rainy seasons.
  - (2) in windy seasons.
  - (3) in sandy soils.
  - (4) if water is applied at low volumes in each irrigation.
  - (5) if irrigated at noon.
33. The most important factor in flood irrigation is
- (1) to have a hard pan under the root zone for retaining water.
  - (2) the quality of irrigation water.
  - (3) to have only aquatic plants to be irrigated.
  - (4) the ability of soil to drain the water quickly to avoid root damage.
  - (5) to have an undulating land.
34. Of the following, select the element that is essential for biological nitrogen fixation.
- (1) Sulphur
  - (2) Zinc
  - (3) Potassium
  - (4) Molybdenum
  - (5) Nitrogen
35. Manganese is required in plants for
- (1) chlorophyll synthesis.
  - (2) nucleic acid synthesis.
  - (3) plant cell formation.
  - (4) photolysis of water.
  - (5) root respiration.
36. The major form of sugar transported from the site of photosynthesis to the rest of the plant is
- (1) glyceraldehyde-3-phosphate.
  - (2) glucose.
  - (3) fructose.
  - (4) ribulose 1,5-bisphosphate.
  - (5) sucrose.
37. following are some features to be considered when designing a landscape in an artistic way.
- |            |                     |
|------------|---------------------|
| A - Colour | B - Texture         |
| C - Mass   | D - Light and shade |
- Of the above, the most important features are
- (1) A, B and C only.
  - (2) A, B, and D only.
  - (3) A, C and D only.
  - (4) B, C and D only.
  - (5) all A, B, C and D.
38. Mycorrhiza is a
- (1) parasitic association between roots and some fungi.
  - (2) symbiotic association between fungi and roots of some higher plants.
  - (3) relationship of ants with the roots of some higher plants.
  - (4) symbiotic relationship between algae and some fungi.
  - (5) parasitic association between weeds and roots of some higher plants.
39. The cell wall of fungi consist of
- (1) cellulose.
  - (2) hemicellulose
  - (3) pectin.
  - (4) chitin.
  - (5) starch.
40. In a label of a pesticide, 'EC' refers to
- (1) Electrical Conductivity.
  - (2) Emulsifiable Concentrate.
  - (3) Effective Concentration.
  - (4) European Community.
  - (5) Enquiry Clause.

41. The herbicide that was banned to be imported to Sri Lanka from 2015 is  
 (1) paraquat. (2) glyphosate.  
 (3) glufosinate ammonium. (4) carbofuran.  
 (5) monocrotopos.
42. One of the main advantages of protected agriculture is  
 (1) the low cost of production. (2) high production per unit area.  
 (3) low inputs. (4) low capital cost.  
 (5) low operational cost.
43. Protected agriculture is more environment friendly as it  
 (1) uses hybrid varieties. (2) uses low amount of agrochemicals.  
 (3) uses only organic manure. (4) does not use any agrochemicals.  
 (5) partly isolated from the normal environment.
44. The biggest importer of Sri Lankan floricultural products in 2014 was  
 (1) The Netherlands. (2) Japan. (3) United Kingdom.  
 (4) Saudi Arabia. (5) Germany.
45. Following statements are based on plant tissue culture.  
 A - MS is one of the growing media available at the market.  
 B - A growing media could be produced locally using the Albert solution.  
 C - Low capital cost involved.  
 D - Virus-free planting materials could be produced.  
 E - Trained personnel is needed.  
 Of the above, the correct statements are  
 (1) A, B, C and D only. (2) A, B, C and E only.  
 (3) A, B, D and E only. (4) A, C, D and E only.  
 (5) B, C, D and E only.
46. Consider the following statements.  
 A - Only ruminant animals can digest fiber rich feedstuffs.  
 B - Though carbohydrate and lipid sources are used as energy supplements in animal feeds, animals have the ability to get energy from protein supplements, too.  
 C - Animal proteins contain more essential amino acids than plant proteins.  
 D - Hybrid Napier is a good quality pasture grass.  
 Of the above, the correct statements are  
 (1) A and B only. (2) B and C only.  
 (3) C and D only. (4) A, B and C only.  
 (5) B, C and D only.
47. Examples for some of the major elements essential for animals are,  
 (1) Ca, Mg, K and Cd. (2) N, P, K and Ca.  
 (3) Ca, P, K and Na. (4) Ca, P, S and Fe.  
 (5) Ca, P, Cr and Zn.
48. Of the following, select the most correct statement.  
 (1) The shape of the egg and colour of the egg shell have a direct influence on egg hatchability.  
 (2) Hatching eggs should be stored for about 3 – 4 days, before setting in the incubator.  
 (3) Soon after hatching, feed and water should be provided to chicks.  
 (4) Artificial incubation is more successful, as suitable conditions can be easily controlled.  
 (5) Eggs are transferred from the setter to the hatcher on the last day of incubation.
49. Estrus synchronization in dairy cattle  
 (1) increases milk production of the farm.  
 (2) increases the uniformity of the herd.  
 (3) facilitates a continuous milk production in the farm.  
 (4) improves the health condition of animals.  
 (5) improves the breeding efficiency of animals.
50. The temperature and time combination used for pasteurization of milk is  
 (1) 72 °C and 30 minutes. (2) 63 °C and 30 minutes.  
 (3) 63 °C and 15 seconds. (4) 150 °C and 15 seconds.  
 (5) 75 °C and 15 seconds.

\*\*\*

සියලු ම හිමිකම් ඇවිරිණි / முழுப் பதிப்புரிமையுடையது / All Rights Reserved

ශ්‍රී ලංකා විභාග දෙපාර්තමේන්තුව ශ්‍රී ලංකා විභාග දෙපාර්තමේන්තුව ශ්‍රී ලංකා විභාග දෙපාර්තමේන්තුව ශ්‍රී ලංකා විභාග දෙපාර්තමේන්තුව  
 இலங்கைப் பரீட்சைத் திணைக்களம் இலங்கைப் பரීட்சைத் திணைக்களம் இலங்கைப் பரීட்சைத் திணைக்களம் இலங்கைப் பரීட்சைத் திணைக்களம்  
 Department of Examinations, Sri Lanka Department of Examinations, Sri Lanka Department of Examinations, Sri Lanka Department of Examinations, Sri Lanka  
 Department of Examinations, Sri Lanka

අධ්‍යයන පොදු සහතික පත්‍ර (උසස් පෙළ) විභාගය, 2015 අගෝස්තු  
 கல்விப் பொதுத் தராதரப் பத்திர (உயர் தர)ப் பரீட்சை, 2015 ஆகஸ்ட்  
 General Certificate of Education (Adv. Level) Examination, August 2015

කෘෂි තාක්ෂණවේදය II  
 விவசாயத் தொழினூட்பவியல் II  
 Agro Technology II

18 E II

පැය තුනයි  
 மூன்று மணித்தியாலம்  
 Three hours

Index No. : .....

### Instructions:

- \* This question paper consists of 10 question in 08 pages.
- \* This question paper comprises of Parts A, B and C.  
 The time allotted for all parts is three hours.

#### PART A - Structured Essay (2-7 pages)

- \* Answer all four questions on this paper itself.
- \* Write your answers in the space provided for each question. Please note that the space provided is sufficient for your answers and extensive answers are not expected.

#### PART B and C - Essay (page No. 8)

- \* Select two questions from each of the Parts B and C and answer four questions only. Use the papers supplied for this purpose. At the end of the time allotted for this paper, tie the three parts together so that Part A is on the top of Part B and C before handing over to the supervisor.
- \* You are permitted to remove only Parts B and C of the question paper from the Examination Hall.

### For Examiner's Use only

Part	Question No.	Marks
A	1	
	2	
	3	
	4	
B	5	
	6	
	7	
C	8	
	9	
	10	
Total		
Percentage		

#### Final Marks

In Numbers	
In Letters	

#### Code Numbers

Marking Examiner 1.	
Marking Examiner 2.	
Marks Checked by	
Supervised by	

**Part A - Structured Essay**  
*Answer all questions on this paper itself.*  
*(Each question carries 10 marks.)*

Do not write in this column

1. (A) Soft technology is based on different components. State **two** such components.

- (1) .....
- (2) .....

(B) State **two** ways to use internet to find information on business management.

- (1) .....
- (2) .....

(C) State a disease condition associated with inadequate dietary intake of each of the following nutrients.

Nutrient	Disease condition
(i) Vitamin A	.....
(ii) Iron	.....
(iii) Iodine	.....
(iv) Calcium	.....

(D) Spoilage of food can be explained as a multi-factorial process.

(i) State **two** factors that are directly associated with chemical spoilage of food.

- (1) .....
- (2) .....

(ii) State **two** possible conditions that directly affect the spoilage of food under unhygienic conditions.

- (1) .....
- (2) .....

(E) State **three** ways that household food security can be promoted.

- (1) .....
- (2) .....
- (3) .....

(F) List **four** factors that has been used to classify agro-ecological regions in Sri Lanka.

- (1) .....
- (2) .....
- (3) .....
- (4) .....

(G) Name the vegetative propagation method shown in each of the figures and state an example of a crop for which the method can be used.

(i) Method : .....  
Crop : .....

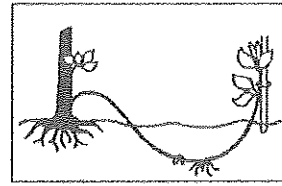

(ii) Method : .....  
Crop : .....

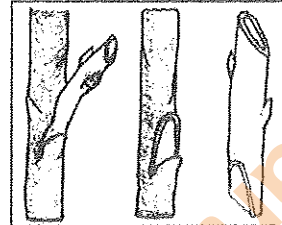

(iii) Method : .....  
Crop : .....

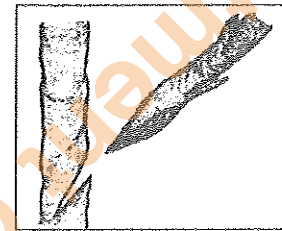

Do not write in this column

2. (A) Name **three** sensitive aquatic ecosystems found in Sri Lanka.

- (1) .....
- (2) .....
- (3) .....

(B) State **two** threats for the sustainability of aquatic systems.

- (1) .....
- (2) .....

(C) State **two** important measures to reduce post-harvest losses of fish related products.

- (1) .....
- (2) .....

(D) State **two** technological methods used to minimize post-harvest losses of grains.

- (1) .....
- (2) .....

(E) State **two** advantages and **two** disadvantages of genetically modified crops.

(i) Advantages

- (1) .....
- (2) .....

(ii) Disadvantages

- (1) .....
- (2) .....

Department of Examinations, Sri Lanka

Do not write in this column

(F) A small-scale yoghurt production business was badly affected due to increased price of raw milk and plastic containers. Few employees have volunteered to resign due to poor financial situation of the business.

(i) State **one** external factor responsible for the current condition of the business.

.....

(ii) State **one** internal factor responsible for the current condition of the business.

.....

(G) A rice miller purchased a new milling machine for Rs 150,000. He received Rs 100,000 as a bank loan at 1% monthly interest and invested another Rs 20,000 to install the machine. His electricity bill per month is Rs 12,000. Answer the following questions.

(i) What is the capital investment of this business?

.....

.....

(ii) Calculate the recurrent expenditure per month for this business

.....

.....

(iii) State **two** additional information that is required to calculate the profit/loss of the business.

(1) .....

(2) .....

(H) State **two** factors that should be considered in selecting a suitable entrepreneurship opportunity.

(1) .....

(2) .....

(I) State **two** examples for risks that could result due to processing food without following proper standards.

(1) .....

(2) .....

(J) Market waste and agricultural waste are suitable raw material for composting. State **two** conditions suitable for better composting of these raw materials.

(1) .....

(2) .....

3. (A) State **one** appropriate alternate technology each for the operations given below to be used in  $\frac{1}{4}$  ha paddy land.

Operation	Appropriate alternate technology
(i) Use of four-wheel tractor for land preparation	.....
(ii) Use of combine harvesters for harvesting	.....

Do not write in this column

(B) Following diagram shows a farm implement.

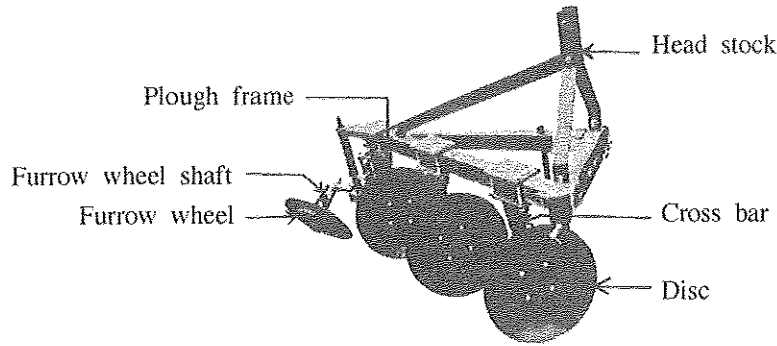

(i) Name the implement.

.....

(ii) Describe the use of this implement in agriculture.

.....  
 .....  
 .....

(iii) State the function of the implement parts named below.

<b>Part</b>	<b>Function</b>
(1) Disc	: .....
(2) Head stock	: .....

(C) State **four** causes of land degradation.

- (1) .....
- (2) .....
- (3) .....
- (4) .....

(D) State a function of each of the parts of a sprinkler irrigation system, given below.

<b>Part</b>	<b>Function</b>
(i) Water pump	: .....
(ii) Water filter	: .....
(iii) Sprinkler head	: .....

(E) State a suitable method of irrigation for each of the following crops.

<b>Crop</b>	<b>Irrigation method</b>
(i) Rice	: .....
(ii) Mango	: .....
(iii) Chilli	: .....

Do not write in this column

(F) (i) State two physiological roles of nitrogen in plants.

(1) .....

(2) .....

(ii) State two deficiency symptoms of calcium in plants.

(1) .....

(2) .....

(G) State whether the following statements on plants are True 'T' or False 'F'.

(i) CO<sub>2</sub> fixation occurs within the stroma. : .....

(ii) One molecule of O<sub>2</sub> is produced for every CO<sub>2</sub> molecule fixed by photosynthesis : .....

(H) State two problems encountered due to trees planted along road sides.

(1) .....

(2) .....

4. (A) A farmer decided to use herbicides to control weeds at 7 days after planting rice in a lowland in the dry zone of Sri Lanka. He selected a foliar applied herbicide, which showed symptoms in 2 - 3 days after application. Answer the following questions.

(i) Using the weed classification based on leaf and stem morphology, state the major group of weeds that the farmer would be targeting to control?  
.....

(ii) Classify the herbicide used by the farmer, based on following criteria.

(1) Time of application : .....

(2) Mode of action : .....

(iii) State an important practice the farmer should adopt 2 - 3 days after applying the herbicide.  
.....

(B) (i) What is metamorphosis?  
.....  
.....

(ii) The diagram below shows a complete metamorphosis of an insect. Name the stages A, B and C.

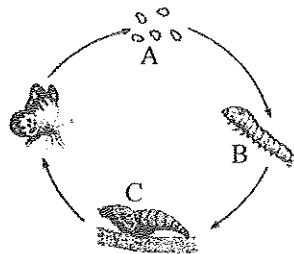

A : .....

B : .....

C : .....

(C) Name four crops that are widely grown inside poly tunnels in Sri Lanka.

(1) .....

(2) .....

(3) .....

(4) .....

Do not write in this column

(D) Name **two** major species of cut flowers and **two** major species of cut foliage that are exported from Sri Lanka.

(i) Cut flowers

(1) .....

(2) .....

(ii) Cut foliage

(1) .....

(2) .....

(E) State **four** advantages of having lawns in landscaping.

(1) .....

(2) .....

(3) .....

(4) .....

(F) Fill in the blanks of the following paragraph.

"Pasture grasses such as ..... are suitable for grassing by cattle. Though cows can get their nutrients by digesting roughage feed with the help of ..... living in the rumen, they should also be fed with some concentrates containing ..... and ..... supplements along with some minerals."

(G) A hatchery operator producing layer type chicks set 50,000 eggs in an incubator. During candling done at the end of the first week of incubation 2,000 eggs were found as clear eggs. At the end of incubation, 40,000 chicks were produced but only little less than 20,000 chicks were selected for sale.

(i) Calculate the hatchability (%) of fertile eggs.

.....  
.....

(ii) Mention the main reason for selecting only less than 20,000 chicks for sale.

.....  
.....

(H) Name **two** hormones responsible for the regulation of oestrus cycle of a cow and their main function.

**Hormone**

**Main function**

(1) .....

(2) .....

(I) State **two** examples of animal products preserved through each of following preservation methods.

(i) Osmotic dehydration .....

(ii) Fermentation .....

\*\*

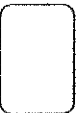

Department of Examinations, Sri Lanka

Department of Examinations, Sri Lanka

Department of Examinations, Sri Lanka

Department of Examinations, Sri Lanka

සියලු ම හිමිකම් ඇවිරිණි / முழுப் பதிப்புரிமையுடையது / All Rights Reserved

ශ්‍රී ලංකා විභාග දෙපාර්තමේන්තුව  
 இலங்கைப் பரீட்சைத் திணைக்களம்  
 Department of Examinations, Sri Lanka

අධ්‍යයන පොදු පහතික පත්‍ර (උසස් පෙළ) විභාගය, 2015 අගෝස්තු  
 கல்விப் பொதுத் தராதரப் பத்திர (உயர் தர)ப் பரீட்சை, 2015 ஆகஸ்ட்  
 General Certificate of Education (Adv. Level) Examination, August 2015

කාමී තාක්ෂණවේදය II  
 விவசாயத் தொழினுட்பவியல் II  
 Agro Technology II

18 E II

### Essay

\* Select two questions from each of the Parts B and C and answer four questions only.  
 (Each question carries 15 marks.)

#### Part B

5. (i) State the advantages and disadvantages of using traditional technology in the development programs of Sri Lanka.  
 (ii) Describe the harmful impacts of waste on the environment.  
 (iii) Explain the importance and strategies to achieve national food security.
6. (i) Explain the possible changes that can occur in food due to spoilage.  
 (ii) Explain the factors that should be considered in planning a healthy diet for school children.  
 (iii) Describe the methods of milk preservation.
7. (i) Justify the following statement.  
 "Biotechnological applications have immensely contributed in achieving high food production."  
 (ii) Describe the characteristics of a good entrepreneur.  
 (iii) Describe how the environmental damages caused due to use of machineries in food production could be minimized.

#### Part C

8. (i) Describe how the combination of appropriate technologies could be used in land preparation in a 1 ha of upland farm.  
 (ii) Explain the importance of 'soft landscape materials'.  
 (iii) Describe methods that can be used to improve soil productivity of a lowland paddy field in a sustainable manner.
9. (i) Explain the advantages and disadvantages of using tissue culture to multiply planting materials for agriculture.  
 (ii) Describe the importance of phosphorus and potassium fertilizer in rice plants.  
 (iii) Explain the importance of environmental temperature in improving the productivity of crops.
10. (i) Explain the environmental impact of using pesticides in a paddy field.  
 (ii) Using appropriate sketches, describe how a solar propagator could be made.  
 (iii) Describe how an egg incubator could be managed to achieve the maximum hatchability of eggs.

\*\*\*

Department of Examinations, Sri Lanka

Department of Examinations, Sri Lanka