

අධ්‍යයන පොදු සහතික පත්‍ර (උසස් පෙළ) විභාගය, 2016 අගෝස්තු
 கல்விப் பொதுத் தராதரப் பத்திர (உயர் தர)ப் பரீட்சை, 2016 ஆகஸ்ட்
 General Certificate of Education (Adv. Level) Examination, August 2016

සිවිල් තාක්ෂණවේදය I
 குடிசாரத் தொழினுட்பவியல் I
 Civil Technology I

14 E I

පැය දෙකයි
 இரண்டு மணித்தியாலம்
 Two hours

Instructions:

- * Answer *all* the questions.
- * Write your **Index Number** in the space provided in the answer sheet.
- * Use of calculators is not allowed.
- * Instructions are given on the back of the answer sheet. Follow those carefully.
- * In each of the questions 1 to 50, pick one of the alternatives from (1), (2), (3), (4), (5) which is **correct** or **most appropriate** and mark your response on the answer sheet with a **cross** (x) in accordance with the instructions given in the back of the answer sheet.

1. The drag force acting on a free falling sphere in a fluid, is expressed as $F = 6\pi\eta aV$, where a is the sphere radius, V is the terminal velocity and η is the absolute viscosity. The SI units of η are
 (1) Pa.s (2) Poise (3) m^2s^{-1} (4) m^2s (5) Nm
2. Density of water at room temperature is found to be 62.4 lbf/ft^3 . Unit weight of water is given as 9.81 kN/m^3 . 1 psi pressure is equal to
 (1) 1.0 kPa (2) 4.1 kPa (3) 5.8 kPa (4) 6.9 kPa (5) 7.2 kPa
3. Certain safety measures for cyclists are suggested below.
 A - Adjust seat to ensure comfort and efficient pedaling.
 B - Check to ensure uneven wear in brake shoes.
 C - Determine tyre pressure based on the weight of rider.
 D - Use a side mirror to look behind, before changing course.
 As a cyclist, which safety measures you would consider taking in order to prevent injury during riding?
 (1) A, B and C only. (2) A, B and D only. (3) A, C and D only.
 (4) B, C and D only. (5) A, B, C and D
4. Alum is a chemical compound used in swimming pools and water purification plants. The specific compound of hydrated Potassium Aluminium Sulphate (ie. Potassium Alum) has the formula $KAl(SO_4)_2 \cdot 12H_2O$. Consider the following statements regarding Alum:
 A - It is a crystallized solid at room temperature.
 B - It is used in water purification, in order to cause negatively charged particles to flocculate.
 C - It also acts as a disinfectant that removes bacteria from water.
 D - It is highly soluble in water.
 Which of the above statements are true?
 (1) A, B and C only. (2) A, B and D only. (3) A, C and D only.
 (4) B, C and D only. (5) A, B, C and D
5. A person has purchased a three-wheeler on credit obtained from a finance company. He intends to serve his semi-urban community, and a few retail outlets in his neighbourhood. Which of the following decisions demonstrate his entrepreneurship traits?
 A - Serve two regular customers to transport their children to the National school (Destination being 3 km away).
 B - Use mobile phone to network with fellow drivers
 C - Offer a discounted rate to regular customers
 D - Use mobile phone to secure night-time hires
 (1) A, B and C only. (2) A, B and D only. (3) A, C and D only.
 (4) B, C and D only. (5) A, B, C and D

6. Select the correct elevation of the object when looking from direction A.

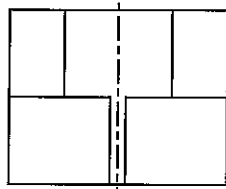

(1)

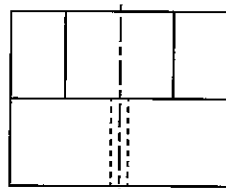

(2)

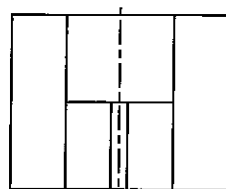

(3)

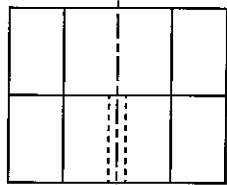

(4)

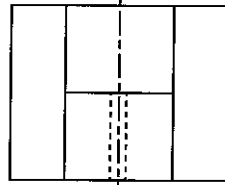

(5)

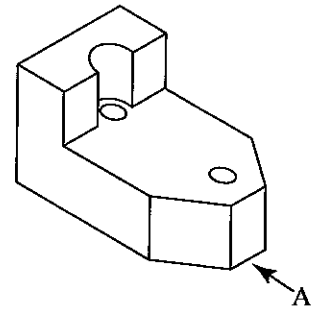

7. Figures 1 and 2 show velocity-time graphs for two projections of a ball. Select the response which gives the most relevant projection. Neglect the air resistance and other relevant resistances.

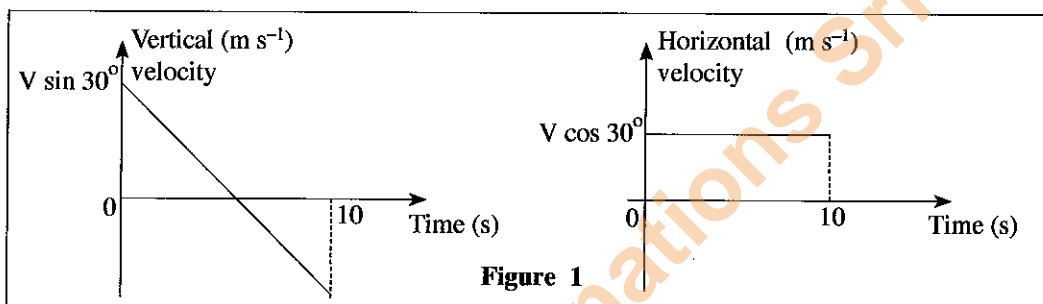

Figure 1

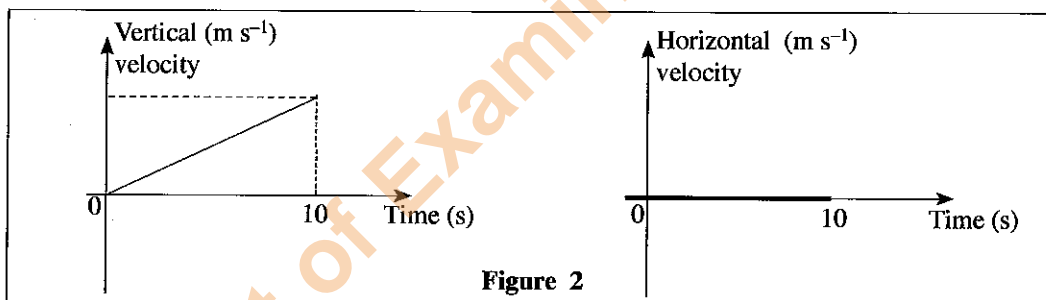

Figure 2

| | Figure 1 | Figure 2 |
|-----|-------------------------------------------------------------------------------------|-----------------------------------------------------------------------------------|
| (1) | Projection of a ball from velocity V at an angle 30° to a horizontal plane | Projection of a ball along a horizontal plane |
| (2) | Projection of a ball along a vertical plane in upward direction | Projection of a ball from velocity V at an angle 30° to a vertical plane |
| (3) | Projection of a ball from velocity V at an angle 30° to a horizontal plane | Drop a ball along a vertical plane from a height |
| (4) | Drop a ball along a vertical plane from a height | Projection of a ball along a horizontal plane |
| (5) | Projection of a ball from velocity V at an angle 30° to a vertical plane | Drop a ball along a vertical plane from a height |

8. Wind and tidal waves are used in turbines and generator sets to convert one form of energy to another. Select the correct energy conversion involved in the process.

(1) Mechanical energy \rightarrow electrical energy

(2) Kinetic energy \rightarrow electrical energy

(3) Potential energy \rightarrow kinetic energy

(4) Potential energy \rightarrow electrical energy

(5) Chemical energy \rightarrow electrical energy

9. Which of the following statements is true about the law of conservation of energy?
- (1) Energy cannot be created nor destroyed, but it can be converted from one form to another.
 - (2) Energy can be created or destroyed, but it cannot be converted from one form to another.
 - (3) Energy cannot be created nor destroyed, nor can it be converted from one form to another.
 - (4) Energy can be created or destroyed, and it can also be converted from one form to another.
 - (5) Energy can be created but cannot be destroyed.
10. Which of the following options given below correctly shows the energy changes involved when a television is on?
- (1) Electrical energy \rightarrow Light and Sound energy \rightarrow Thermal energy
 - (2) Electrical energy \rightarrow Thermal energy \rightarrow Light and Sound energy
 - (3) Light and Sound energy \rightarrow Thermal energy \rightarrow Electrical energy
 - (4) Thermal energy \rightarrow Light and Sound energy \rightarrow Electrical energy
 - (5) Thermal energy \rightarrow Electrical energy \rightarrow Light and Sound energy
11. Select the proper optical arrangement for the reflector of a front head lamp of a car.
- (1) Plane mirror
 - (2) Plane glass
 - (3) Concave mirror
 - (4) Convex mirror
 - (5) Lens arrangement
12. A 75 W incandescent lamp is installed in a house wiring circuit. It is switched on for 2 hours in the morning and for 6 hours at night. Owner decided to replace the 75 W incandescent lamp with 15 W CFL lamp to reduce power consumption. What is the expected saving in daily power consumption?
- (1) 480 kWh
 - (2) 48 kWh
 - (3) 0.48 kWh
 - (4) 600 kWh
 - (5) 0.6 kWh
13. A bipolar junction transistor is tested to identify whether it is working or faulty. A multimeter is switched to ohm scale and the positive testing probe is connected to the base and the negative testing probe is connected to the emitter. Then a low resistance is displayed. After interchanging the probes, a high resistance is shown. Consider the following conclusions regarding the transistor.
- A - It is a NPN type transistor
 - B - It is a PNP type transistor
 - C - Base-emitter junction is broken
 - D - Base-emitter junction is in good condition
 - E - Data are not sufficient to reach any conclusions.
- Select the most accurate statement/s.
- (1) A and C only.
 - (2) B and D only.
 - (3) A and D only.
 - (4) B and C only.
 - (5) E only.
14. What is the equivalent resistance and standard power values for one equivalent resistor which can be used between A and B, instead of the resistor bank?

- (1) 200 k Ω / 2W
- (2) 50 k Ω / 1W
- (3) 50 k Ω / 2W
- (4) 20 k Ω / 2W
- (5) 120 k Ω / 2W

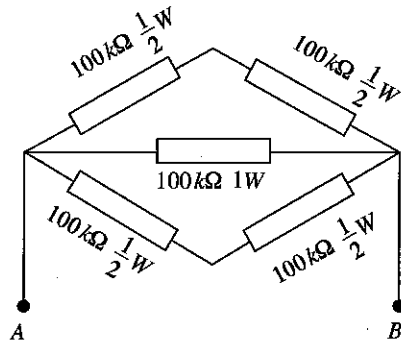

15. A, B and C circuits given below are used for an amplifier. Select the circuit/s which can protect the amplifier when supply connections are interchanged.

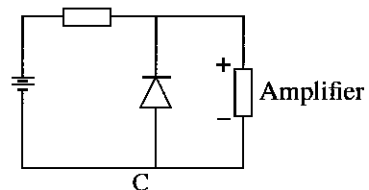
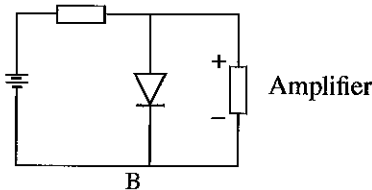
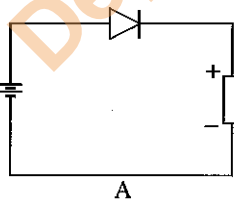

- (1) A only
- (2) A and B only
- (3) A and C only
- (4) B and C only
- (5) A, B and C all

16. What is the symbol used for a logic gate with an output logic state equal to 0, only when logic states of all inputs are equal only to zero?

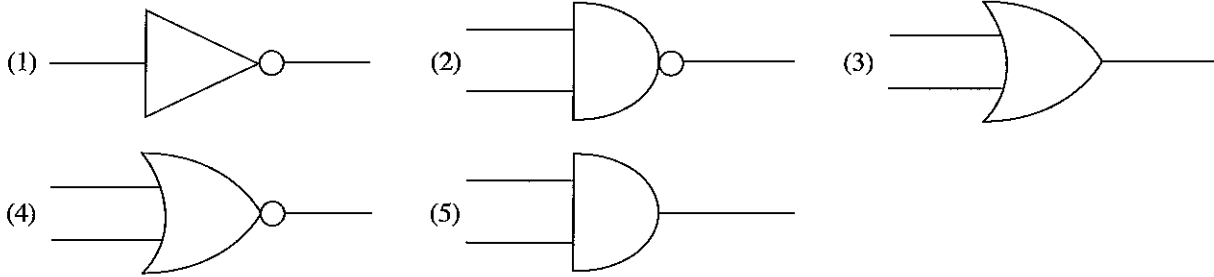

17. Consider the following circuit arrangements. Select the option that gives the ascending order of ammeter readings.

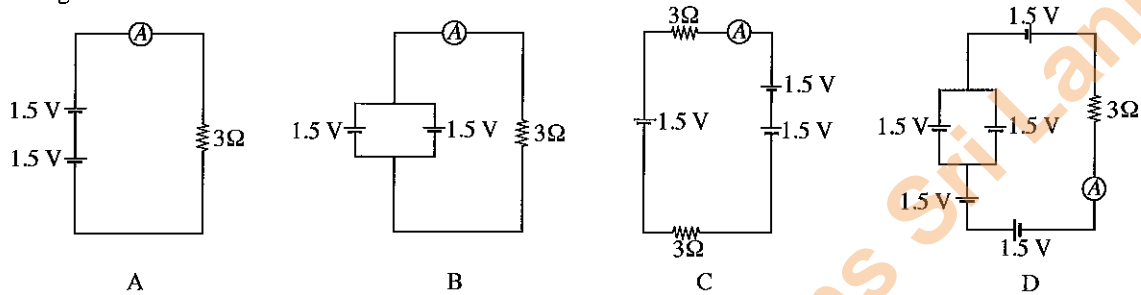

- (1) C, B, A, D (2) A, B, C, D (3) A, B, D, C (4) D, C, B, A (5) C, A, B, D

18. Select the option which gives the correct symbols for electronic components given below in corresponding order from A to E.

A - NPN transistor B - PNP transistor C - Diode
D - Capacitor E - Light emitting diode

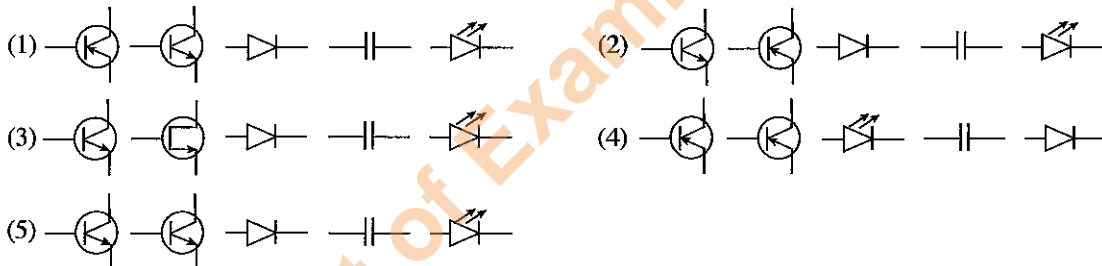

19. Which one of the following best describe the relationship between the buoyancy force of an object submerged in a fluid?

- (1) The buoyancy force is equal to the mass of the object.
(2) The buoyancy force is equal to the weight of the fluid.
(3) The buoyancy force is equal to the mass of the fluid that the object displaces.
(4) The buoyancy force is equal to the weight of the fluid that the object displaces.
(5) The buoyancy force is equal to the density of the fluid.

20. When an aeroplane is taking off passengers inside the cabin may feel a pain in their ears. This can be due to

- A - Air pressure reduction with increasing altitude.
B - Sound of the engine of the aeroplane.
C - Temperature increase with increasing altitude.
D - Reduction of the density of air with increasing altitude.

- (1) A only. (2) B only. (3) A and C only. (4) A and D only. (5) B and C only.

• Answer the following questions 21 and 22, assuming $g = 10 \text{ m/s}^2$.

21. A train engine reaches a speed of 36 kmh^{-1} from zero velocity within 5 seconds. It weights 120 tons and the friction coefficient between its wheels and the rail track is 0.4. The generated frictional resistance is

- (1) 12 kN (2) 120 kN (3) 48 kN (4) 480 kN (5) 960 kN

22. The force generated from the engine described in question 21 is
 (1) 480 kN (2) 240 kN (3) 270 kN
 (4) 232 kN (5) 720 kN

23. 360 kg weight is lifted through a frictionless pulley arrangement as shown in the figure. The force to be applied at P would be

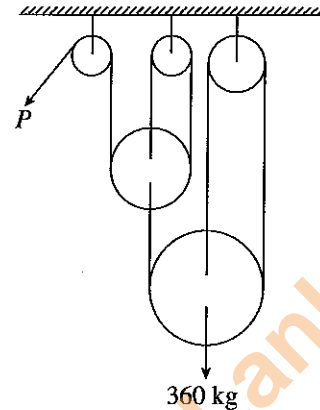

- (1) 60 kg
 (2) 120 kg
 (3) 40 kg
 (4) 80 kg
 (5) 150 kg

24. What are the correct statements regarding the friction force?

- A - The friction force between two surfaces can be increased by increasing the surface areas.
 B - The friction force between two surfaces can be changed by changing the roughness of each surface.
 C - The friction force is used in automobiles to carry out useful tasks.
 D - By changing the roughness of two surfaces, coefficient of friction between those surfaces can be changed.

- (1) A, B and C only. (2) A, B and D only. (3) A, C and D only.
 (4) B, C and D only. (5) A, B, C and D.

25. A measurement obtained from a vernier calliper is shown in the figure.
 What is its reading?

- (1) 3.16 cm
 (2) 2.40 cm
 (3) 2.16 cm
 (4) 4.80 cm
 (5) 2.46 cm

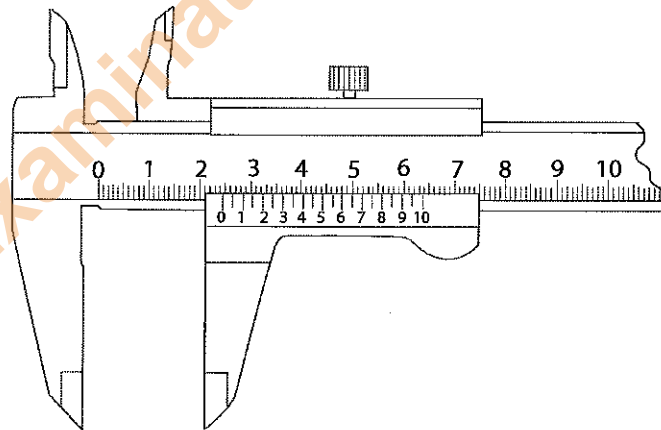

26. The task that is **not** relevant to the person preparing a bill of quantities is

- (1) calculating cement quantity for a concrete mix.
 (2) extracting the details of doors and windows from the building plan.
 (3) calculating concrete volume for a floor slab.
 (4) calculating quantities of materials used for roofing.
 (5) estimating the volume of earthwork for foundations.

27. Which of the following is the **incorrect** statement when taking quantities for a building project?

- (1) cement mortar work is measured in square feet.
 (2) concrete volumes are measured in cubic meters.
 (3) columns and beams are sometimes measured in linear feet.
 (4) tiling work is measured in cubic feet.
 (5) excavation for foundations is measured in cubic meters.

28. Following are some of the instruments used in surveying field work.

- A - Chain B - Levelling instrument
 C - Pegs D - Ranging poles

The instruments used for chain surveying are;

- (1) A, B and C only. (2) A, B and D only. (3) A, C and D only.
 (4) B, C and D only. (5) A, B, C and D.

29. Given below are four steps used when setting out an optical theodolite, prior to making an observation.
- A - Placing the theodolite on the tripod and centering it over the peg.
 - B - Fixing and centering the tripod over the peg.
 - C - Centering the circular level bubble of theodolite using the tripod legs.
 - D - Centering the plate level bubble of the theodolite using the foot screws.

The correct order of steps used during setting out is;

- (1) A, B, C and D. (2) B, C, A and D. (3) B, A, D and C.
 (4) A, B, D and C. (5) A, C, B and D.
30. Which of the following state institutions is **not** responsible for monitoring the industrial effluent discharge to streams and rivers?
- (1) Central Environment Authority (2) National Water Supply and Drainage Board
 - (3) Geological Surveys and Mines Bureau (4) Municipal councils
 - (5) Department of Agriculture

31. Figure shows a reinforcement cage used in a simply supported reinforced concrete beam.

- A - Element X carries a tensile force
- B - Elements Y helps to confine concrete within the reinforcement cage
- C - Element Y carries stress
- D - Element Z carries a compressive force

Which of the above statements are true?

- (1) B and C (2) C and D
 (3) A, C and D (4) B, C and D only
 (5) A, B, C and D

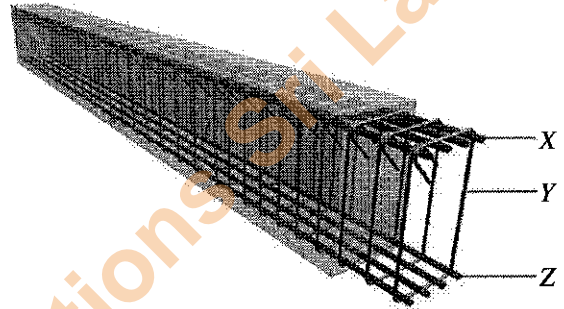

32. Which of the following reasons explain the purpose of curing reinforced concrete structural members?

- A - To reduce formation of a cement slurry on the surface
- B - To preserve intended strength of concrete
- C - To prevent loss of water due to evaporation
- D - To reduce shrinkage of concrete

- (1) A, B and C only (2) A, B and D only (3) A, C and D only
 (4) B, C and D only (5) A, B, C and D

33. Some statements about the concrete are given below.

- A - Workability of concrete reduces with increasing transportation time
- B - Workability of concrete reduces with increasing water/cement ratio
- C - Workability of concrete reduces with increasing air bubbles in the concrete mix
- D - Workability of concrete reduces with increasing angularity of coarse aggregate

Which of the above statements are true regarding concrete?

- (1) A and B (2) A and C (3) A and D (4) B and C (5) B and D

34. Figure shows details of an Acro-jack connection. Which one of the named parts does **not** carry any stress?

- (1) A
 (2) B
 (3) C
 (4) D
 (5) E

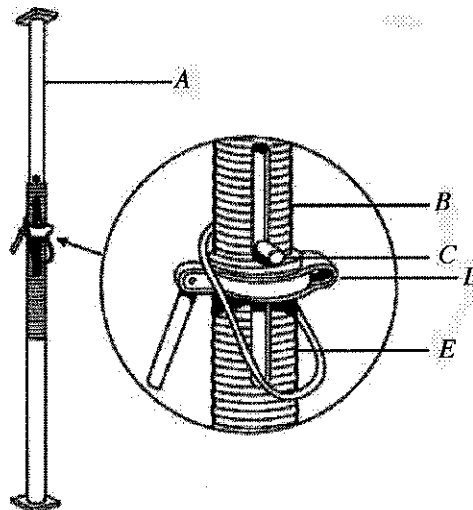

35. Figure shows a reinforced concrete lintel beam spanning over a window opening.

- A - The two wall supports are considered to be fixed supports.
- B - Top fibres of the beam at mid-span are in compression.
- C - Shear stresses may exist along the length of the beam.
- D - The beam is subjected to torsion.

Which of the above statements are true?

- (1) A, B and C only
- (2) A, B and D only
- (3) A, C and D only
- (4) B, C and D only
- (5) A, B, C and D

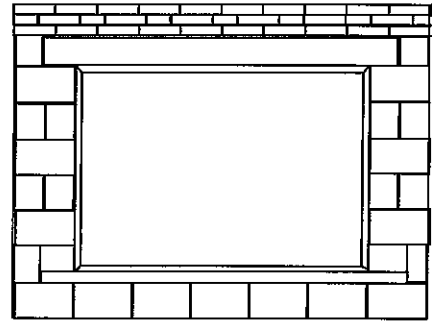

36. Figure shows the stress-strain behaviour of a low-carbon steel, observed during a standard tensile test.

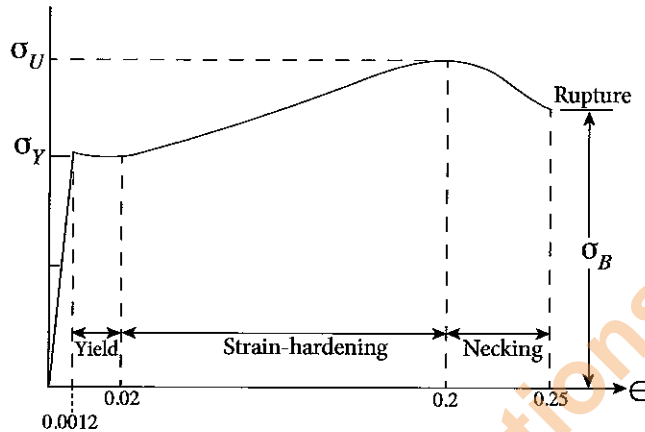

Consider the following statements on stress-strain behaviour.

- A - Yielding of the specimen occurs at constant stress.
- B - Linear stress-strain behaviour is observed for elastic strains only.
- C - Strain-hardening causes its yield strength to increase.
- D - During rupture, a reduction in the cross-sectional area is observed.

Of the above, which statements are correct?

- (1) A, B and C only
- (2) A, B and D only
- (3) A, C and D only
- (4) B, C and D only
- (5) A, B, C and D

37. In most single storey dwellings structural loads are transferred to ground via a continuous plinth foundation made of Random-Rubble Masonry. Which of the following statements are true?

- A - Width of the foundation depends on the bearing capacity of the soil beneath.
- B - The plinth wall gains its strength from cemented inter-locking rubble stones.
- C - Plinth walls support load bearing brick walls and reinforced concrete columns.
- D - A 1:5 cement mortar mix is recommended for plinth walls that support load bearing walls.

- (1) A, B and C only
- (2) A, B and D only
- (3) A, C and D only
- (4) B, C and D only
- (5) A, B, C and D

38. Identify the correct statements that describe the purposes of the following elements.

- A - The sub-grade supports the sub-base, to carry vehicle axle loads.
- B - The bituminous surface treatment prevents water infiltration.
- C - The road base and sub-base consists of compacted graded aggregate.
- D - In-situ soil formation may serve as a road sub-base.

- (1) A, B and C only
- (2) A, B and D only
- (3) A, C and D only
- (4) B, C and D only
- (5) A, B, C and D

39. Sri Lanka's speed limit for all vehicles within school areas and hospitals is

- (1) 20 km/h.
- (2) 25 km/h.
- (3) 30 km/h.
- (4) 35 km/h.
- (5) 40 km/h.

40. Tie measurements are
- (1) measurements taken for error checking.
 - (2) measurements taken for locating bench marks.
 - (3) included angle between two chain lines in a traverse.
 - (4) level measurements in a contour survey.
 - (5) Whole Circle Bearing of a chain line.
41. Which of the following statements is **incorrect** regarding incineration of solid waste?
- (1) There is a significant reduction in the volume and weight of waste.
 - (2) The ash can contain heavy metals and other toxic substances.
 - (3) The incinerators are relatively economical to construct.
 - (4) The incineration process can be used to generate electricity.
 - (5) Incineration should be done at elevated temperatures.
42. A rectangular roof top (15 m x 12.5 m) of a building receives an average daily rainfall of 15 mm during a particular month of the year. If the rain water falls on the roof to be used for rainwater harvesting, what is the minimum tank capacity required to store rain water of 2 days? (The rainwater harvesting system has a water collection efficiency of 75%.)
- (1) 4.20 cubic meters
 - (2) 2.11 cubic meters
 - (3) 4.22 cubic meters
 - (4) 3.20 cubic meters
 - (5) 4.25 cubic meters
43. The minimum distance to be kept between the septic tank and a drinking water well according to the local government authority requirements is
- (1) 40 feet.
 - (2) 50 feet.
 - (3) 80 feet.
 - (4) 60 feet.
 - (5) 110 feet.
44. Given below are several statements regarding building construction regulations.
- A - Any residential building is entitled to obtain a 3-phase electricity supply.
 - B - A two storey building can get separate electricity connections for both floors.
 - C - Minimum possible sub-divided land space, in a land survey, is 6 perches.
 - D - Electricity supply can be obtained for a residential building, during its construction period.
- Out of them, which statements are correct?
- (1) A and B only.
 - (2) A and C only.
 - (3) A, B and C only.
 - (4) B, C and D only.
 - (5) A, B, C and D.
45. Following are some statements regarding quality of different water sources on earth.
- A - River water may contain clay particles.
 - B - Water of deep tube wells may contain calcium and magnesium salts.
 - C - Water of shallow wells may contain only a small amount of minerals.
 - D - Salinity of water in inland reservoirs can be high.
- Out of them, which statements are correct?
- (1) A, B and C only.
 - (2) A, C and D only.
 - (3) A, B and D only.
 - (4) B, C and D only.
 - (5) A, B, C and D.
46. Given below are some statements regarding an overhead storage tank in a domestic water supply.
- A - Increasing the elevation of the storage tank will increase the water pressure in the system.
 - B - Increasing the diameter of the outlet pipe from storage tank will increase water pressure in the system.
 - C - Water pressure can be maintained even during a pressure drop in the main supply pipe.
 - D - Extra amount of water can be stored for immediate use.
- Out of them, which statements are correct?
- (1) A, B and C only.
 - (2) B, C and D only.
 - (3) A, C and D only.
 - (4) A, B and D only.
 - (5) A, B, C and D.
47. The reason to fix an aeration pipe to a septic tank is
- (1) to remove carbon dioxide generated in the septic tank.
 - (2) to facilitate sewer flow into the septic tank under gravity.
 - (3) to remove any blockage which can occur inside sewer lines.
 - (4) to supply oxygen for microbial activity.
 - (5) to add water to facilitate sewer flow.

48. The following statements are about fire exit which is an essential component in multi-storied buildings.

- A - Spiral exits are not suitable as occupants might feel tired when using.
- B - Construction materials is not an important consideration when constructing fire exits.
- C - Fire exits must be braced sufficiently to reduce vibrations.
- D - Entrance to fire exit must be constructed at the corner of the building.

Which of these statements can be true about fire exits?

- (1) A and B only.
- (2) B and C only.
- (3) C and D only.
- (4) A and C only.
- (5) A and D only.

49. Following statements are about storing cement which is an essential construction material in modern engineering constructions.

- A - Cement must be stored in a damp proof environment.
- B - Orientation of cement bags is not an important consideration when storing cement.
- C - First in first out is a good practice for stored cement.
- D - Cement bags should be always stored on wooden planks.

Which of the above statements can be true about storing cement in a construction site?

- (1) A, B and C only.
- (2) A, B and D only.
- (3) B, C and D only.
- (4) A, C and D only.
- (5) A, B, C and D.

50. Consider the following statements.

- A - The soaking pit is designed to discharge kitchen waste water to the ground.
- B - The septic tank is a storage of digested solid waste.
- C - The inlet level of a septic tank should always be lower than its outlet level.
- D - A sealed septic tank requires a vent.

Out of them, which statements are true regarding a domestic sewer system?

- (1) A, B and C only.
- (2) A, B and D only.
- (3) A, C and D only.
- (4) B, C and D only.
- (5) A, B, C and D.

* * *

Department of Examinations Sri Lanka

Department of Examinations Sri Lanka

ශ්‍රී ලංකා විභාග දෙපාර්තමේන්තුව ශ්‍රී ලංකා විභාග දෙපාර්තමේන්තුව ශ්‍රී ලංකා විභාග දෙපාර්තමේන්තුව ශ්‍රී ලංකා විභාග දෙපාර්තමේන්තුව ශ්‍රී ලංකා විභාග දෙපාර්තමේන්තුව
 இலங்கைப் பரீட்சைத் திணைக்களம் இலங்கைப் பரීட்சைத் திணைக்களம் இலங்கைப் பரීட்சைத் திணைக்களம் இலங்கைப் பரීட்சைத் திணைக்களம் இலங்கைப் பரීட்சைத் திணைக்களம்
 Department of Examinations, Sri Lanka Department of Examinations, Sri Lanka Department of Examinations, Sri Lanka Department of Examinations, Sri Lanka Department of Examinations, Sri Lanka
 ශ්‍රී ලංකා විභාග දෙපාර්තමේන්තුව ශ්‍රී ලංකා විභාග දෙපාර්තමේන්තුව ශ්‍රී ලංකා විභාග දෙපාර්තමේන්තුව ශ්‍රී ලංකා විභාග දෙපාර්තමේන්තුව ශ්‍රී ලංකා විභාග දෙපාර්තමේන්තුව
 இலங்கைப் பரීட்சைத் திணைக்களம் இலங்கைப் பரීட்சைத் திணைக்களம் இலங்கைப் பரීட்சைத் திணைக்களம் இலங்கைப் பரීட்சைத் திணைக்களம் இலங்கைப் பரීட்சைத் திணைக்களம்
 Department of Examinations, Sri Lanka Department of Examinations, Sri Lanka Department of Examinations, Sri Lanka Department of Examinations, Sri Lanka Department of Examinations, Sri Lanka

අධ්‍යයන පොදු සහතික පත්‍ර (උසස් පෙළ) විභාගය, 2016 අගෝස්තු
 கல்விப் பொதுத் தராதரப் பத்திர (உயர் தர)ப் பரீட்சை, 2016 ஓகஸ்ட்
 General Certificate of Education (Adv. Level) Examination, August 2016

සිවිල් තාක්ෂණවේදය II
 குடிசாரத் தொழினுட்பவியல் II
 Civil Technology II

14 E II

පැය තුනයි
 மூன்று மணித்தியாலம்
 Three hours

Index No. :

Important :

- * This question paper consists of 12 pages.
- * This question paper comprises Parts A, B and C. The time allotted for all parts is three hours. (Use of calculators is not allowed.)

Part A - Structured Essay (09 pages)

- * Answer all the questions on this paper itself.
- * Write your answers in the space provided for each question. Note that the space provided is sufficient for your answers and that extensive answers are not expected.

Part B and C - Essay (03 pages)

- * Select minimum of two questions from each of the parts B and C and answer four questions only. Use the papers supplied for this purpose. At the end of the time allotted for this paper, tie the three parts together so that Part A is on the top of Part B and C before handing over to the supervisor.
- * You are permitted to remove only Parts B and C of the question paper from the Examination Hall.

For Examiner's Use Only

| Part | Q. No. | Marks |
|------------|--------|-------|
| A | 1 | |
| | 2 | |
| | 3 | |
| | 4 | |
| B | 1 | |
| | 2 | |
| | 3 | |
| C | 4 | |
| | 5 | |
| | 6 | |
| Total | | |
| Percentage | | |

Final Marks

| | |
|------------|--|
| In Numbers | |
| In Words | |

Code Numbers

| | |
|--------------------|--|
| Marking Examiner 1 | |
| Marking Examiner 2 | |
| Checked by | |
| Supervised by | |

PART A – Structured Essay
 Answer *all four* questions on this paper itself.

Do not
 write
 in this
 column

1. An isometric view of a machine component is shown in Figure 1. Machine component is symmetric along the vertical plane passing through X-X. Two holes of diameter 10 mm ($\Phi 10$) passes completely through the component. Assuming any missing dimensions, draw the following views to a suitable scale using first angle projection principle. Show all relevant dimensions in the sketches. Use the graph sheets given on page 3 and 4 to answer the questions. (All dimension are in mm.)

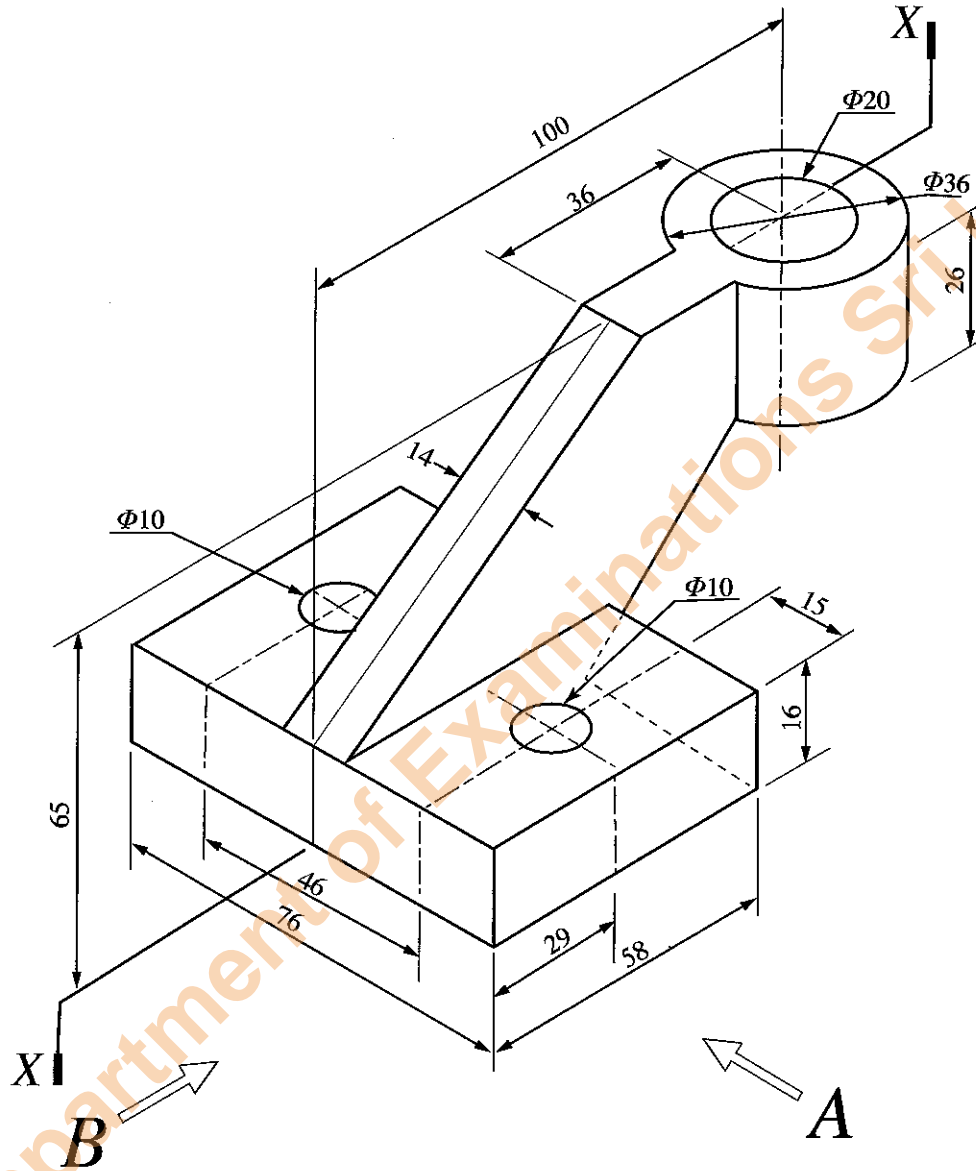

- (i) Front elevation seen through direction A.
 (ii) End elevation seen through direction B.
 (iii) Plan.

Department of Examinations Sri Lanka

Department of Examinations Sri Lanka

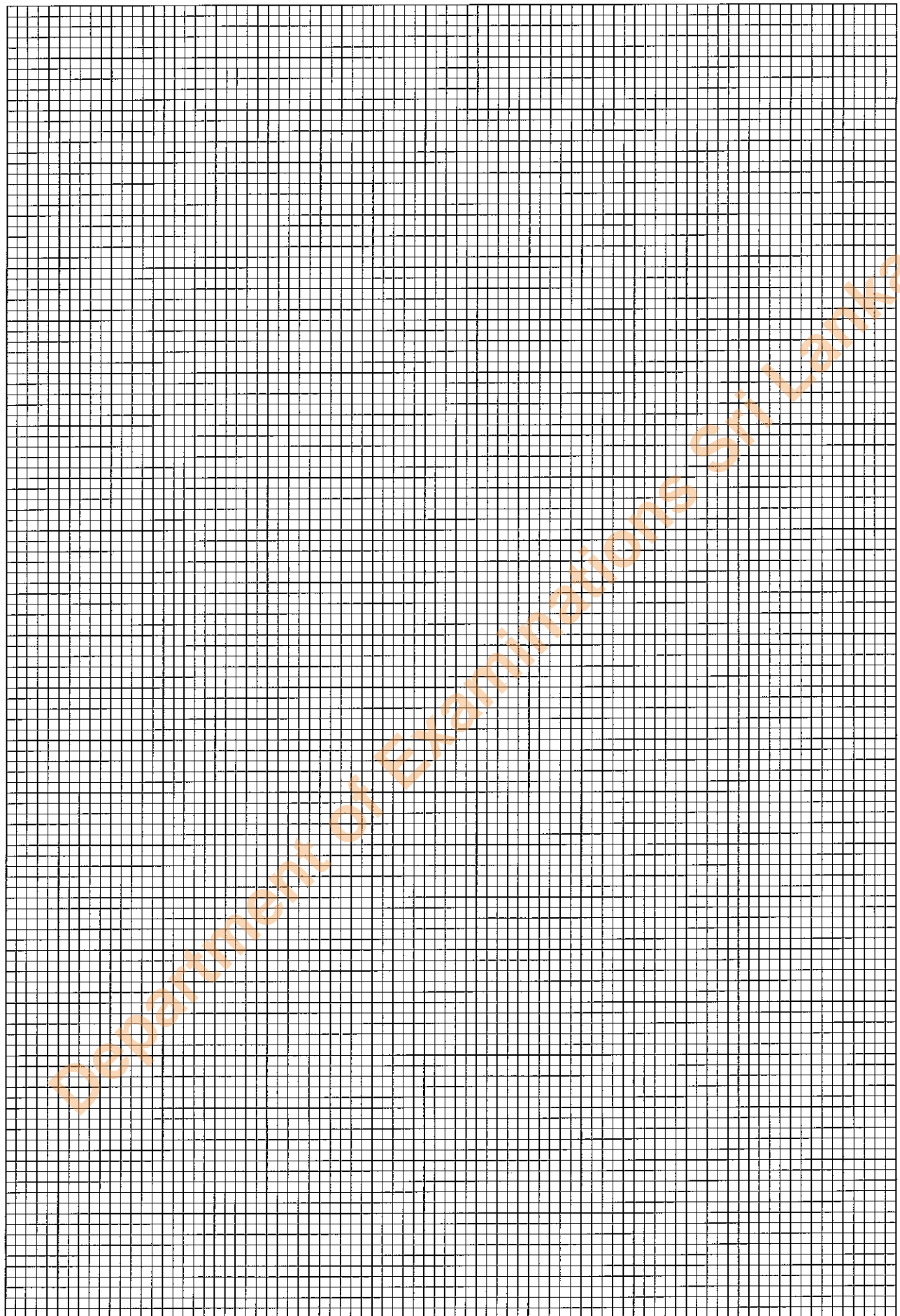

[see page five

Do not write in this column

2. ABC school has a computer laboratory and a conference room. As the IT technician, you are assigned with the task to upgrade the IT facilities of the ABC school. The computer laboratory has 20 working desktop computers. It is decided to add another 30 computers to the laboratory.

(a) 10 computers will be assembled by using the components in good working condition from computers removed from the laboratory due to various faults. Consider that the following list of components are in good working condition.

- Mother board 15 units
- Casing of the system unit with power supply and other accessories 20 units
- RAM card 10 units
- Hard disk 15 units
- LCD monitor 15 units
- Mouse 15 units
- Keyboard 20 units
- DVD player and writer 10 units

Note: Assume that all hardware items are compatible and large stock of cables and connectors are available.

(i) Select **four** items required to assemble a basic system unit from the available list.

- (1)
- (2)
- (3)
- (4)

(ii) List another **three** hardware items required to prepare a fully functional computer in addition to the system units.

- (1)
- (2)
- (3)

(iii) Assume that these ten computer units will be used to prepare documents, presentations, create drawings and to edit pictures. List **four** softwares required to make these ten computers fully functional.

- (1)
- (2)
- (3)
- (4)

(b) Assume that ten computers have been assembled and another twenty computers have been bought. Currently computers are not connected to a computer network and no internet facilities are available.

(i) List **three** hardware items required to create a computer network of fifty computers.

- (1)
- (2)
- (3)

Do not write in this column

(ii) Propose a method to supply the internet facilities for the computer laboratory.

.....

.....

.....

.....

(c) The conference room will be renovated with multimedia facilities, facilities for video conferencing, for conducting workshops and seminars by resource persons from distance places using online facilities.

(i) List **three** input/output hardware devices required for the computer in addition to the basic input/output devices.

(1)

(2)

(3)

(ii) Mention **one** specific software required for the conference room in addition to the basic application software.

.....

.....

3. A roof for an agricultural equipment storage shed is to be constructed using galvanized corrugated sheets. The building is made of block-work and its inner dimensions are 6m x 3m. The two opposite sides have blank gable walls. The metal sheets have dimensions 1800mm x 875mm. A typical specification for metal sheets is given below.

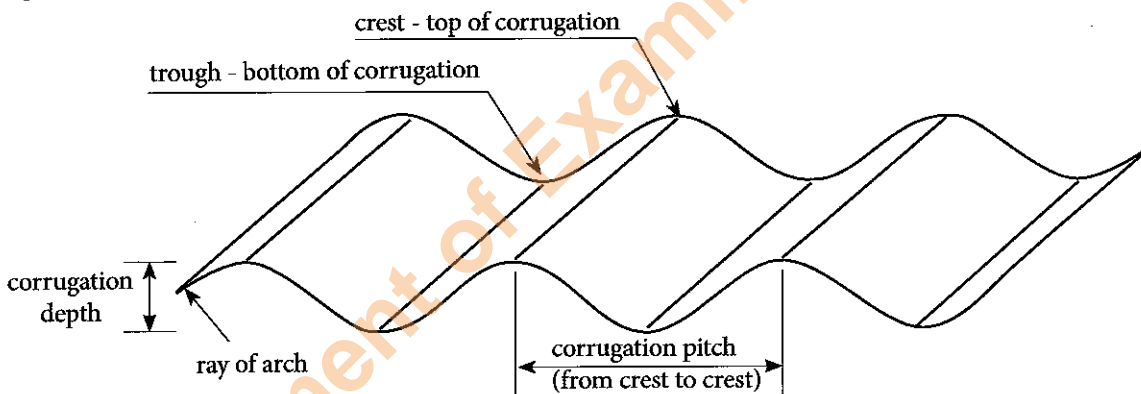

| Specification for CGI | Recommended for Roofing (According to Nepal Standard) |
|---------------------------------|----------------------------------------------------------------------------------------|
| Minimum thickness | 0.35 mm |
| Zinc Coating | Hot dip galvanization with minimum 120 g/m ² zinc on each side of the sheet |
| Approximately weight per bundle | 55 kg |
| Nominal Pitch of Corrugation | 18 mm (tolerance +/- 1.5 mm) |
| Nominal Pitch of Corrugation | 76.2 mm (tolerance +/- 2 mm) |
| No of Corrugation | 1/2 + 10 + 1/2 |
| Width of Sheet | 875 mm (tolerance +/- 10 mm) |

<https://www.shettercluster.org>

Do not
write
in this
column

- (a) Sketch the timber structure of roof indicating sizes of timber members, its layout and spacing. State any assumptions you have made.

- (b) State the roof pitch you would recommend for the structure. Discuss your selection.

.....
.....
.....

- (c) Explain, using sketches, how you would lay the sheets, while preventing water infiltration through the roof.

Department of Examinations Sri Lanka

Department of Examinations Sri Lanka

(d) Explain, using sketches, how you would fasten the sheets to the timber structure, to protect roof sheets against uplift forces, and to prevent infiltration of water through the roof.

Do not
write
in this
column

(e) Provide a sketch to show how you intend to cap along the roof ridge.

Department of Examinations Sri Lanka



Do not write in this column

4. Water meters provided by the National Water Supply and Drainage Board are used to determine monthly domestic water usage.

(a) State the standard unit of measurement used for this purpose. State the least quantity of water that can be measured using such water meters.

.....

(b) A water meter is used to measure the consumption of a household with five persons. Compute the daily consumption, in standard units, based on a per capita use of 120 litres per day. Compute the monthly consumption of this household. State any assumption you have made.

.....

.....

.....

(c) The house owner suspects that the meter is faulty and as a result he is 'over billed'. Explain how he could verify that there is a water leak in the domestic supply system, and the reason for over billing is not a faulty water meter.

.....

.....

.....

(d) Having checked for leaks in the supply system, explain how he could verify that over-billing is infact due to the faulty water meter.

.....

.....

.....

(e) Pipe borne water may contain significant amount of calcium and magnesium salts. Explain how these salts may affect components of a domestic water supply system, including the water meter.

.....

.....

.....

.....

.....

.....

* *



Department of Examinations Sri Lanka

Department of Examinations Sri Lanka

Department of Examinations Sri Lanka

Department of Examinations Sri Lanka

සියලු ම හිමිකම් ඇවිරිණි / முழுப் பதிப்புரிமையுடையது / All Rights Reserved

ශ්‍රී ලංකා විභාග දෙපාර්තමේන්තුව ශ්‍රී ලංකා විභාග දෙපාර්තමේන්තුව ශ්‍රී ලංකා විභාග දෙපාර්තමේන්තුව ශ්‍රී ලංකා විභාග දෙපාර්තමේන්තුව ශ්‍රී ලංකා විභාග දෙපාර්තමේන්තුව
 இலங்கைப் பரீட்சைத் திணைக்களம் இலங்கைப் பரීட்சைத் திணைக்களம் இலங்கைப் பரීட்சைத் திணைக்களம் இலங்கைப் பரීட்சைத் திணைக்களம் இலங்கைப் பரීட்சைத் திணைக்களம்
 Department of Examinations, Sri Lanka Department of Examinations, Sri Lanka Department of Examinations, Sri Lanka Department of Examinations, Sri Lanka Department of Examinations, Sri Lanka
 ශ්‍රී ලංකා විභාග දෙපාර්තමේන්තුව ශ්‍රී ලංකා විභාග දෙපාර්තමේන්තුව ශ්‍රී ලංකා විභාග දෙපාර්තමේන්තුව ශ්‍රී ලංකා විභාග දෙපාර්තමේන්තුව ශ්‍රී ලංකා විභාග දෙපාර්තමේන්තුව
 இலங்கைப் பரීட்சைத் திணைக்களம் இலங்கைப் பரීட்சைத் திணைக்களம் இலங்கைப் பரීட்சைத் திணைக்களம் இலங்கைப் பரීட்சைத் திணைக்களம் இலங்கைப் பரීட்சைத் திணைக்களம்
 Department of Examinations, Sri Lanka Department of Examinations, Sri Lanka Department of Examinations, Sri Lanka Department of Examinations, Sri Lanka Department of Examinations, Sri Lanka

අධ්‍යයන පොදු සහතික පත්‍ර (උසස් පෙළ) විභාගය, 2016 අගෝස්තු
 கல்விப் பொதுத் தராதரப் பத்திர (உயர் தர)ப் பரீட்சை, 2016 ஓகஸ்ட்
 General Certificate of Education (Adv. Level) Examination, August 2016

සිවිල් තාක්ෂණවේදය II
 குடிசார்த் தொழினுட்பவியல் II
 Civil Technology II

14 E II

පැය තුනයි
 மூன்று மணித்தியாலம்
 Three hours

Essay

- * Select **two** questions from each of the **Parts B and C** and answer **four** questions only.
 (Give concise answers. Sketch clear figures and label them where necessary.
 (Each question carries 15 marks.)

Part B

1. Sri Lanka's most households are connected to the main electricity supply, which has been improved due to recent rural electrification projects.

- (a) Lighting is a main electricity consumption need in urban homes. Now there is a trend in replacing previous CFL and incandescent lamps with LED lights for improving the efficiency and thereby reducing the electricity consumption. Consider the following details of a house.

| Lighting item | Number | Power rating | Daily usage (hours) | Units consumed per month (kWh) |
|-------------------------------|--------|--------------|---------------------|--------------------------------|
| 1) Indoor CFL lamps | 05 | 15 W | 8 | |
| 2) Indoor CFL lamps | 03 | 10 W | 6 | |
| 3) Indoor incandescent lamps | 04 | 40 W | 4 | |
| 4) Outdoor incandescent lamps | 01 | 75 W | 6 | |
| 5) Outdoor incandescent lamps | 01 | 100 W | 6 | |

Calculate the monthly power consumption of lighting items mentioned in the table.

- (b) Owner is planning to replace existing lights with more efficient LED lamps. Following table gives a comparison of incandescent, CFL and LED lamps based on light output.

| Incandescent (W) | With equivalent light output CFL (W) | With equivalent light output LED (W) |
|------------------|--------------------------------------|--------------------------------------|
| 40 | 10 | 4 |
| 60 | 13 | 6 |
| 75 | 18 | 9 |
| 100 | 23 | 16 |

Suggest LED options for each lighting item mentioned in (a) based on the details in the table.

- (c) (i) Calculate the total monthly electric energy consumption for the items mentioned in (a) in kWh with LED lamps.
 (ii) Calculate the percentage energy saving achieved by replacing the existing lighting.
- (d) Initial cost of LED is high compared to CFL and incandescent lamps. However, the lifetime of LED is very much higher than CFL and incandescent lamps.
- (i) Explain how you can consider these facts in selecting lamps for household application. Assume that the cost of a CFL is six times the incandescent lamp and cost of LED is 20 times the incandescent lamps. Lifetime of LED is 5 times the CFL and lifetime of CFL is 10 times the incandescent lamps.
- (ii) Explain the effect of efficiency improvement if you use CFL instead of LED for selected one in part (b) by considering cost factor and the lifetime. Consider one example and justify your answer.

2. Figure shows a sketch of a home-built concrete mixer made of items that can be purchased from a general hardware store.

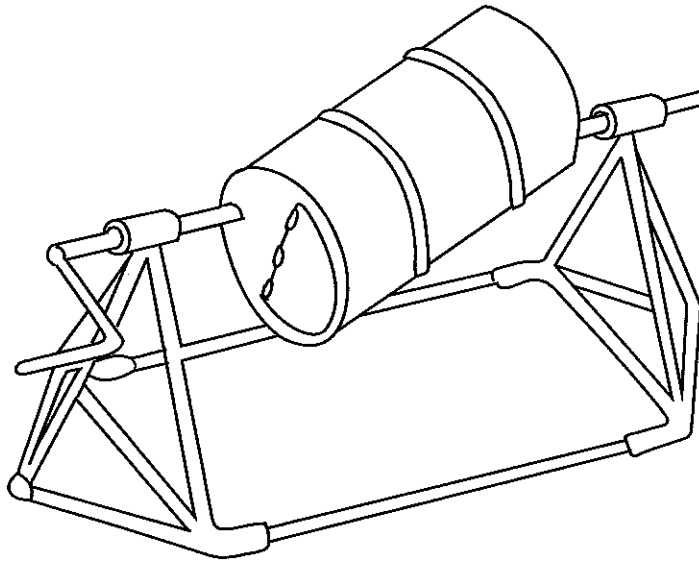

Suppose that your team is given the task to design and built the said device for your school building project.

- Sketch the sectional view of the rotating parts to an approximate scale, on a vertical plane passing through its rotating axis. Show details of connection between the drum and its axle, and steps taken to reduce energy loss due to friction.
 - Estimate the volume of concrete you could mix in a single batch. Explain how you have arrived at the estimated value. State any assumptions you have made in this regard.
 - Estimate the amount of torque that one has to give in order to rotate the drum, when it is mixing the quantity of concrete estimated in (b) above. Explain how you have arrived at the estimated value. State any assumptions you have made in this regard.
3. Congenital disorders, diseases, injuries and accidents have caused a considerable number of differently-abled persons living with amputated limbs, weak limbs and loss of vision, hearing or speech. Societies have now accepted the need to make their life comfortable and to facilitate them to contribute to society, to the best of their abilities. In this regard, technological innovations are playing a greater role. Select one type of disability of your choice.
- Discuss how modern technological innovations have made such individuals to be productive individuals.
 - Explain how the innovations discussed in 3(a) above, facilitates such individuals to live with their family and loved ones comfortably, rather than living in a facility dedicated to such individuals.
 - Describe instances where such individuals can contribute to their household and/or society while being differently-abled.

Part C

4. A typical layout of a column-slab arrangement of a two-storeyed residential building is shown in the figure.

- List equipment and accessories you would use when setting out the columns and the slab.
- Sketch the reinforcement details for beam BCD. Name the items using standard notations.
- Sketch the reinforcement details for slab panel A if 10 mm steel bars are used for this purpose. Name the items using standard notations.

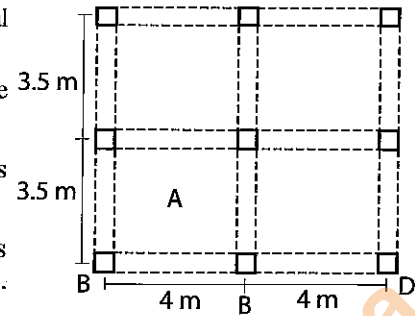

5. Figure shows a proposed building plan for a village community centre. Four corners of the building are constructed with 225 mm x 225 mm reinforced concrete columns with 900 mm x 900 mm square pad foundations. Walls are 225 mm thick brick walls and height of AB and DC walls are 3.0 m. Walls AD and BC are gabled walls with a centre height of 3.6 m. All dimensions in the figure are in mm.

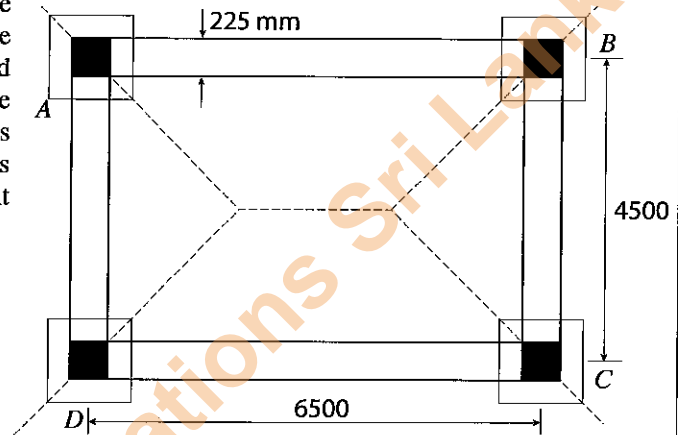

Prepare taking-off sheets for the following items.

- Excavation for the foundation
- Concrete for the foundation
- Brick paving
- Brick wall

State any assumptions you have made.

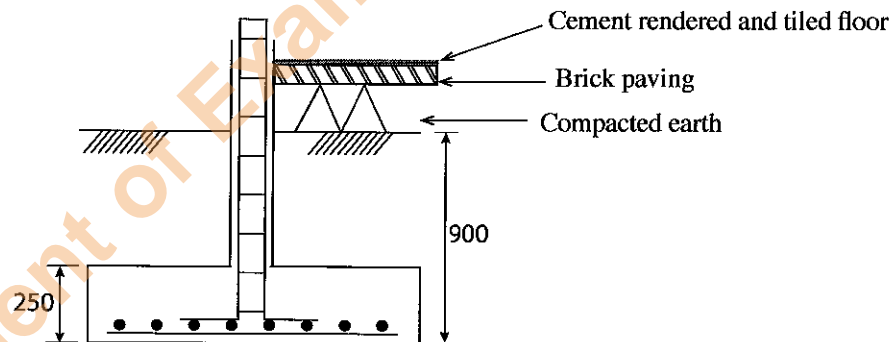

6. A domestic rainwater collection system is to be designed for housing units in the dry zone of Sri Lanka. The roof is a simple two sided gable-roof with 12 m length, and the horizontal distance between the two roof gutters is 10 m. Water is collected using down pipes. The two gutters are connected to down pipes located at one end of the building. Water that is collected by the down pipes are channelled to the collection tanks via a sand filter.

- If the average daily rainfall during the rainy season is 20 mm, and assuming a rainwater collection efficiency of 80%, determine the required tank capacity to collect three days of collection.
- Provide a sketch, which shows the assembly of the rainwater collection and distribution system. Name the important components.
- If the household wishes to use rain water for drinking and cooking purposes, discuss the measures that should be taken in order to maintain the required water quality.

* * *

Department of Examinations Sri Lanka

Department of Examinations Sri Lanka