

ශ්‍රී ලංකා විභාග දෙපාර්තමේන්තුව ශ්‍රී ලංකා විභාග දෙපාර්තමේන්තුව ශ්‍රී ලංකා විභාග දෙපාර්තමේන්තුව ශ්‍රී ලංකා විභාග දෙපාර්තමේන්තුව ශ්‍රී ලංකා විභාග දෙපාර්තමේන්තුව
 இலங்கைப் பரீட்சைத் திணைக்களம் இலங்கைப் பரීட்சைத் திணைக்களம் இலங்கைப் பரීட்சைத் திணைக்களம் இலங்கைப் பரීட்சைத் திணைக்களம் இலங்கைப் பரීட்சைத் திணைக்களம்
 Department of Examinations, Sri Lanka Department of Examinations, Sri Lanka Department of Examinations, Sri Lanka Department of Examinations, Sri Lanka Department of Examinations, Sri Lanka
 ශ්‍රී ලංකා විභාග දෙපාර්තමේන්තුව ශ්‍රී ලංකා විභාග දෙපාර්තමේන්තුව ශ්‍රී ලංකා විභාග දෙපාර්තමේන්තුව ශ්‍රී ලංකා විභාග දෙපාර්තමේන්තුව ශ්‍රී ලංකා විභාග දෙපාර්තමේන්තුව
 இலங்கைப் பரීட்சைத் திணைக்களம் இலங்கைப் பரීட்சைத் திணைக்களம் இலங்கைப் பரීட்சைத் திணைக்களம் இலங்கைப் பரීட்சைத் திணைக்களம் இலங்கைப் பரීட்சைத் திணைக்களம்
 Department of Examinations, Sri Lanka Department of Examinations, Sri Lanka Department of Examinations, Sri Lanka Department of Examinations, Sri Lanka Department of Examinations, Sri Lanka

අධ්‍යයන පොදු සාහිත්‍ය පත්‍ර (උසස් පෙළ) විභාගය, 2016 අගෝස්තු
 கல்விப் பொதுத் தராதரப் பத்திர (உயர் தர)ப் பரீட்சை, 2016 ஆகஸ்ட்
 General Certificate of Education (Adv. Level) Examination, August 2016

ඉංජිනේරු තාක්ෂණවේදය I
 பொறியியற் தொழினுட்பவியல் I
 Engineering Technology I

65 E I

පැය දෙකයි
 இரண்டு மணித்தியாலம்
 Two hours

Instructions:

- * Answer all the questions.
- * Write your Index Number in the space provided in the answer sheet.
- * Instructions are given on the back of the answer sheet. Follow those carefully.
- * In each of the questions 1 to 50, pick one of the alternatives from (1), (2), (3), (4), (5) which is correct or most appropriate and mark your response on the answer sheet with a cross (x) in accordance with the instructions given at the back of the answer sheet.
- * Each questions carries 03 marks totalling to 150.
- * Use of calculators is not allowed.

1. A measuring ruler has been graduated up to 0.5 mm. The maximum error that can be expected according to its graduation in measuring length is
 (1) ±1.0 mm. (2) ±0.75 mm. (3) ±0.5 mm. (4) ±0.25 mm. (5) ±0.05 mm.
2. The capacitance of a 5 μF capacitor is equal to
 (1) 5 × 10³ pF. (2) 5 × 10⁶ pF. (3) 5 × 10⁹ pF. (4) 5 × 10¹² pF. (5) 5 × 10¹⁵ pF.
3. The correct views of the following isometric object, if viewed from the directions of arrows A and B respectively are (figures are not drawn to scale),

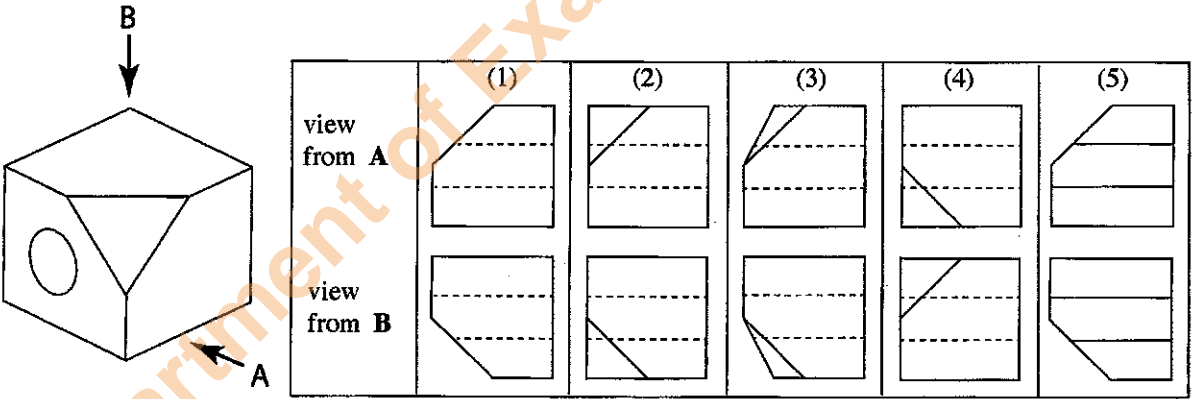

4. It is required to cut a thin metal sheet using an oxyacetylene flame. The flame that should be used for this is
 (1) a flame rich with acetylene.
 (2) a flame rich with oxygen.
 (3) a neutral flame.
 (4) a carburising flame.
 (5) a flame containing an inert gas together with oxygen and acetylene.
5. A factor that did not challengingly influence the development of engineering technology is
 (1) depleting resources. (2) rules and regulations.
 (3) commercialisation. (4) existing technological knowledge.
 (5) wars.

Department of Examinations Sri Lanka

6. Information related to Sumedha, Ganeshan, Rizana and Michael is given below.

- A - Sumedha runs his business in a very uncertain market while improving it.
- B - Ganeshan introduced a new commodity to the market to face his competitors.
- C - Rizana continues the business which was started by her father while earning profits as usual.
- D - Michael is an owner of a business who runs business despite losses.

According to the above statements, a high level of entrepreneurial characteristics is shown by,

- (1) Sumedha and Ganeshan.
- (2) Sumedha and Michael.
- (3) Ganeshan and Rizana.
- (4) Sumedha and Rizana.
- (5) Ganeshan and Michael.

7. The figure below shows the market behaviour with regard to a commodity.

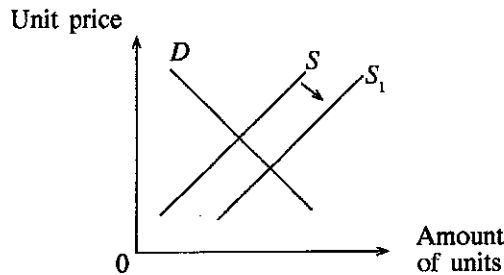

According to the above figure, a main reason for the displacement of supply curve from S to S_1 may be,

- (1) increased price of the commodity.
 - (2) improved quality of the commodity.
 - (3) increased relative profit margin of the commodity.
 - (4) increased consumer liking.
 - (5) increased income of consumers.
8. The included angles that were measured from three survey stations in a theodolite traverse were respectively $108^\circ 53' 40''$, $38^\circ 12' 20''$ and $32^\circ 53' 45''$. The total correction to be applied for correcting the error that has occurred here is

- (1) $-15''$
- (2) $-05''$
- (3) $00''$
- (4) $+05''$
- (5) $+15''$

9. The direct distance between two cities A and B is 25 km. The direct distance between these cities in a map drawn to a scale of 1 : 250 000 is

- (1) 1 mm.
- (2) 2.5 mm.
- (3) 1 cm.
- (4) 2.5 cm.
- (5) 10 cm.

10. Surveyor's field book note containing perpendicular offsets taken from survey line AD for boundary points B, C and E are given below. The area of the polygon-shaped land ABCDEA is

- (1) 450 m^2
- (2) 500 m^2
- (3) 550 m^2
- (4) 600 m^2
- (5) 650 m^2

	D	
	40.0	
	35.0	10.0 C
E 10.0	20.0	
	5.0	10.0 B
	0.0	
	A	

11. Consider the following statements regarding chain surveying.

- A - All survey stations used must be clearly visible from each other.
- B - Triangles used must be well conditioned triangles.
- C - The lengths of the sides of the triangles used must be equal as far as possible.

Of the above, the correct statement/s is/are

- (1) B only.
- (2) A and B only.
- (3) A and C only.
- (4) B and C only.
- (5) All A, B and C.

12. The standard measurements of a paper of size A1 are (Consider A4 size paper as $210 \text{ mm} \times 297 \text{ mm}$.)

- (1) $594 \text{ mm} \times 420 \text{ mm}$.
- (2) $420 \text{ mm} \times 594 \text{ mm}$.
- (3) $594 \text{ mm} \times 840 \text{ mm}$.
- (4) $840 \text{ mm} \times 1188 \text{ mm}$.
- (5) $297 \text{ mm} \times 420 \text{ mm}$.

13. Several brick bond types are shown in the following figures.

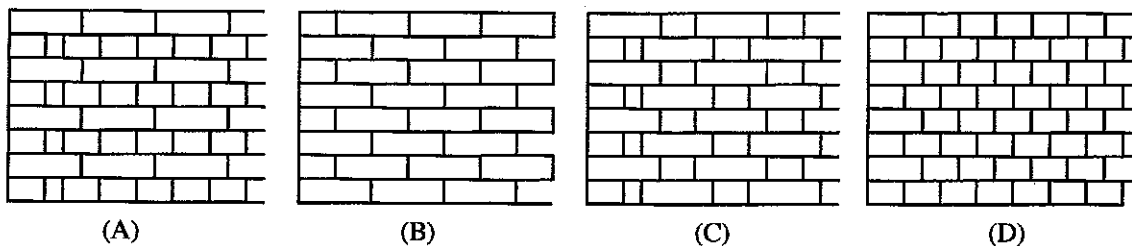

The bond types shown here in A, B, C and D are respectively

- (1) English, Flemish, Stretcher and Header.
- (2) English, Stretcher, Header and Flemish.
- (3) English, Stretcher, Flemish and Header.
- (4) Stretcher, Flemish, English and Header.
- (5) Header, Flemish, Stretcher and English.

14. The following figure shows a timber roof structure.

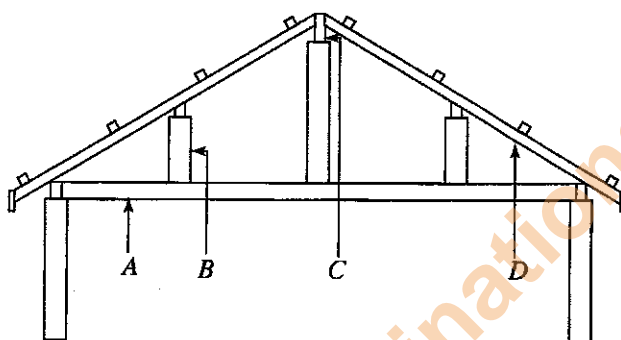

The components marked as A, B, C and D are respectively,

- (1) ridge, post, tie beam and rafter.
- (2) post, ridge, tie beam and rafter.
- (3) rafter, post, ridge and tie beam.
- (4) tie beam, post, ridge and rafter.
- (5) tie beam, ridge, post and rafter.

15. The following statements are regarding an engineering brick.

A - The length of a brick equals to the twice of its breadth and the length of the joint.

B - When a brick is immersed in water for 24 hours, water absorption should not exceed approximately $\frac{1}{5}$ th of the dry weight of the brick.

C - When bricks are allowed to strike one another a metallic sound should be produced.

Of the above, the correct statement/s is/are

- (1) A only.
- (2) A and B only.
- (3) A and C only.
- (4) B and C only.
- (5) All A, B and C.

16. When the standard light plane is decided, the angle used is

- (1) $61\frac{1}{2}^\circ$
- (2) $62\frac{1}{2}^\circ$
- (3) $63\frac{1}{2}^\circ$
- (4) $64\frac{1}{2}^\circ$
- (5) $65\frac{1}{2}^\circ$

17. In order to obtain a smooth finish in the plastering of internal walls, the most suitable ratio between cement : lime : sand to be used is

- (1) 1 : 1 : 5
- (2) 1 : 2 : 5
- (3) 1 : 2 : 4
- (4) 1 : 1 : 2
- (5) 1 : 3 : 6

18. The figure shows the main parts of door frame of a house

The components marked as A, B, C and D are respectively,

- (1) holdfast, spurstone, jamb post and rebate.
- (2) tenon, holdfast, rebate and horn.
- (3) spurstone, holdfast, jamb post and rebate.
- (4) spurstone, holdfast, rebate and head.
- (5) tenon, holdfast, jamb post and rebate.

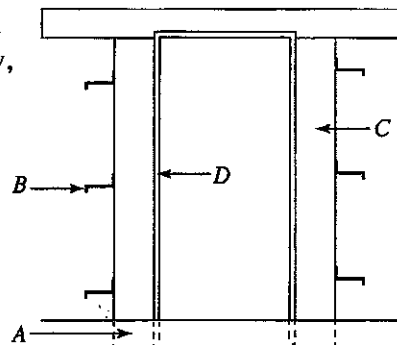

[See page four

19. The statements given below are regarding a simple foundation.
 A - The stability of a building can be increased by the foundation.
 B - The complete weight of the building can be transmitted to the earth by the plinth wall.
 C - Screed concrete is used to separate the earth in the excavated foundation trench from the concrete.
 Of the above, the correct statement/s is/are
 (1) A only. (2) A and B only. (3) A and C only.
 (4) B and C only. (5) All A, B and C.
20. What is the property of mortar that helps to form any shape?
 (1) Tensile property (2) Plasticity (3) Utility
 (4) Ductility (5) Compressive property
21. Concrete is cured to
 (1) increase the strength. (2) remove air pockets.
 (3) get a smooth surface. (4) keep the moisture.
 (5) reduce shrinkage.
22. The items used for calculating unit rates using bills of quantities are given below.
 A - rate for material
 B - rate for labour
 C - overheads
 D - rate for tools and equipment
 E - profit
 The items included in the gross unit rate are
 (1) A only. (2) A and B only.
 (3) A, B and C only. (4) A, B, C and D only.
 (5) All A, B, C, D and E.
23. Which is **not** a recognized institution that formulates standards and specifications relevant to the construction industry?
 (1) SMMI (2) SLSI (3) ISO (4) BSI (5) ICTAD
24. The most important property that should be taken into consideration when selecting a fluid for power transmission is
 (1) porosity. (2) elasticity. (3) viscosity.
 (4) incompressibility. (5) density.
25. Several statements regarding metal working technology, are given below.
 A - Only cylindrical parts and holes can be produced on a lathe.
 B - Plastic deformation takes place in forming steel.
 C - Steel can be formed only at high temperatures.
 Of the above, the correct statement/s is/are
 (1) A only. (2) B only. (3) C only.
 (4) A and B only. (5) A and C only.
26. Select correct statement regarding the power transmission system of a motor vehicle.
 (1) If the diameter of the wheels is increased, a motor vehicle can travel at increased speeds.
 (2) When the gear ratio of the gear box is increased, the ability of a motor vehicle to accelerate decreases.
 (3) When the gear ratio of the final drive is increased, the motor vehicle will have the ability to travel at an increased speed.
 (4) The two universal joints at both ends of the propeller shaft influence the acceleration of the vehicle.
 (5) The size of the flywheel increases with the increasing number of cylinders in an engine.
27. What is **not** used for maintaining timing between the crankshaft and the camshaft?
 (1) toothed belts (2) chain drives (3) gear wheels
 (4) sprocket wheels (5) V-belts
28. Among the components used in a motor-car suspension system, the most contributing component for the energy loss is the
 (1) shock absorber. (2) coil spring. (3) leaf spring.
 (4) torsion bar. (5) tyre.

29. What is the correct statement related to the technology of motor vehicles?
- (1) An ABS system continuously applies brakes on all the wheels until the motor vehicle completely stops.
 - (2) The central surface of a tyre wears early when the tyre is under inflated.
 - (3) It is possible to store large amount of oil inside a small chamber because lubrication oil pump pressurises lubrication oil.
 - (4) The front region of a motor vehicle is manufactured with increased toughness for the additional safety of passengers.
 - (5) When disconnecting the battery terminals of a motor vehicle, it is safer to first disconnect the terminal connected to the body of the motor vehicle.
30. What is the correct statement with regard to the special techniques associated with motor vehicle technology?
- (1) Super charger, for its operation, does not require the power generated by the engine.
 - (2) Turbo charger pressurises the exhaust gas before it is fed back to the engine.
 - (3) Since the Exhaust Gas Recirculation (EGR) system feeds back part of the exhaust gas to the engine, it is possible to reduce the overall amount of CO₂ emitted by the engine.
 - (4) The particulate emission contained in the exhaust gas is minimised by the 3-way catalytic converter.
 - (5) The maximum temperature inside the combustion chamber is lowered by an EGR system.
31. The fuel injector of cylinder number 1 of a four-stroke engine releases fuel 1000 times in a minute. What is the speed of the engine in revolutions per minute?
- (1) 250 (2) 500 (3) 1000 (4) 2000 (5) 4000
32. What is the correct statement about the cooling systems used in motor vehicles?
- (1) When the engine is operating at its optimum temperature, the pressure inside the radiator is higher than the atmospheric pressure.
 - (2) The thermostatic valve is used to measure the temperature of the coolant.
 - (3) The main mode of heat loss in the radiator is radiation.
 - (4) Two coolant pumps are used in thermo syphon cooling system.
 - (5) By lowering the engine temperature below the ambient temperature, it is possible to increase fuel efficiency.
33. In the process of refrigeration,
- (1) pressures are equal inside the condenser and the evaporator.
 - (2) evaporator releases heat to the environment.
 - (3) liquid refrigerant evaporates by releasing heat.
 - (4) refrigerant exists in the gaseous state inside the compressor.
 - (5) condenser absorbs heat from the environment.
34. Consider the following statements.
- A - Slider crank mechanism converts reciprocating motion into rotary motion.
B - Worm and wheel are used when rotation speeds need to be changed in small amounts.
C - Bevel gears are used only to transmit rotary motion in a perpendicular direction.
- Of the above, the correct statement/s is/are
- (1) A only. (2) B only. (3) C only.
(4) A and B only. (5) A and C only.
35. Which is **not** a factor for safety considered in designing fluid machines?
- (1) Capacity (2) Safety valves
 - (3) Factor of safety (4) Overload switches
 - (5) Pressure relief valves
36. Out of the statements given below which one is true about engineering standards and specifications?
- (1) ISO standards have been prepared to satisfy various standards.
 - (2) The price of a commodity can be considered as a specification.
 - (3) The task of a technical committee is to purchase goods according to the standards.
 - (4) Technology committees supply standards.
 - (5) Standards positively influence the quality of a product.
37. Single-phase electrical supply voltage and its frequency used in Sri Lanka are respectively
- (1) 240 V and 50 Hz. (2) 230 V and 60 Hz. (3) 220 V and 50 Hz.
(4) 230 V and 50 Hz. (5) 240 V and 60 Hz.

38. When there is a electrical leakage in domestic electric appliance, the accessory that should operate to automatically disconnect electricity from the system is
- (1) the fuse connected to the appliance.
 - (2) the miniature circuit breaker in the relevant circuit.
 - (3) earth leakage/residual current circuit breaker.
 - (4) electrical isolator.
 - (5) miniature circuit breaker of the electrical supply.
39. According to the international electrical engineering rules and regulations the colours of the live, neutral and earth wires of a single-phase electrical supply system must be,
- (1) red, brown and green with a yellow stripe.
 - (2) blue, brown and green with a yellow stripe.
 - (3) blue, brown and green.
 - (4) brown, blue and green.
 - (5) brown, blue and green with a yellow stripe.
40. When a solenoid having N turns is subjected to a magnetic field with a rate of change of flux equal to $\frac{d\phi}{dt}$, the induced electromotive force according to the principles of electro-magnetic induction is $E_o = -N \frac{d\phi}{dt}$. When a solenoid having 100 turns is subjected to a magnetic field which has magnetic flux changing from 0.003 Wb to 0.004 Wb in 0.1 seconds, the magnitude of the induced electromotive force is
- (1) 0.1 V. (2) 0.5 V. (3) 1 V. (4) 2 V. (5) 3 V.
41. A fire has started in the main electrical distribution board of a building. There are fire extinguishers coloured in red, black and blue installed at a nearby place. What are the colour/s of fire extinguishers which should be used for extinguishing the fire?
- (1) red and black (2) red and blue (3) black only
 - (4) red only (5) blue and black
42. A star-delta starter is used for starting a three-phase induction motor. If this motor is connected to a three-phase supply of 400 V 50 Hz, values of the voltages in its windings when connected as star and delta respectively are
- (1) 400 V and $\frac{400}{\sqrt{3}}$ V (2) $\frac{400}{\sqrt{3}}$ V and 400 V (3) $400\sqrt{3}$ V and 400 V
 - (4) 400 V and 400 V (5) 400 V and $400\sqrt{3}$ V
43. An electric bulb has been connected to a direct current supply of 24 V. It was found that the resistance between its terminals was 288 Ω after lighting it for about 5 minutes. The power of the bulb is
- (1) 1 W. (2) 2 W. (3) 4 W. (4) 8 W. (5) 20 W.
44. For the operation of a Junction Field Effect Transistor (JFET),
- (1) the pn junction between gate and source should be reverse biased.
 - (2) the pn junction between gate and source should be forward biased.
 - (3) drain should connect with the earth.
 - (4) gate should connect with the supply voltage.
 - (5) the pn junction between gate and source should be forward biased and the drain should connect with the earth.
45. Which graph shows the voltage wave across R_L corresponding to the input signal of the following circuit?

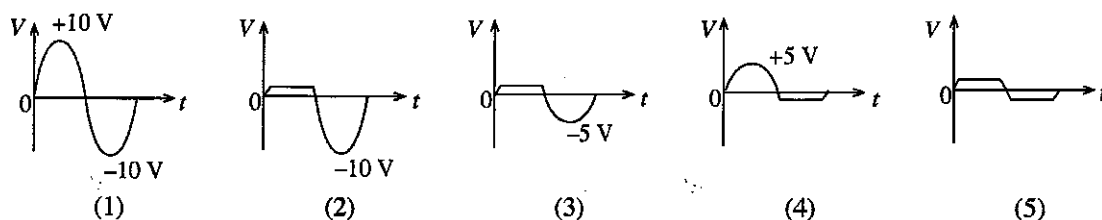
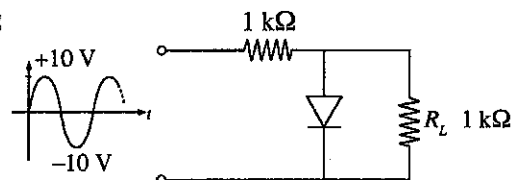

46. The difference between an oscillator and an amplifier is
- (1) oscillator has a high voltage gain.
 - (2) oscillator does not require an input signal.
 - (3) oscillator does not require a direct current supply.
 - (4) the output voltage of an oscillator is always constant.
 - (5) voltage gain of the oscillator is high and output voltage is always constant.

47. An essential characteristic of an operational amplifier is **not**
- (1) high open-loop voltage gain.
 - (2) low power.
 - (3) high input impedance.
 - (4) low output impedance.
 - (5) high frequency gain band width.

48. In the following circuit when the input signal voltage (V_{in}) is increased with respect to the earth, the voltage (V_{out}) of the output signal
- (1) increases.
 - (2) decreases.
 - (3) not change.
 - (4) initially increases and then decreases.
 - (5) initially decreases and then increases.

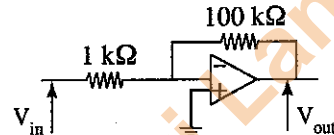

49. The Boolean expression $Y = \bar{A}B + AB + A\bar{B}$ is equivalent to

- (1) a only
- (2) b only.
- (3) c only.
- (4) a and b only.
- (5) b and c only

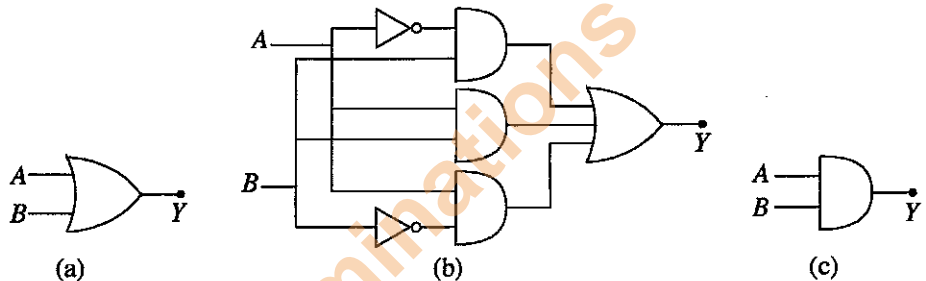

50. Consider the following electrical waves with respect to modulations drawn to the same time scale.

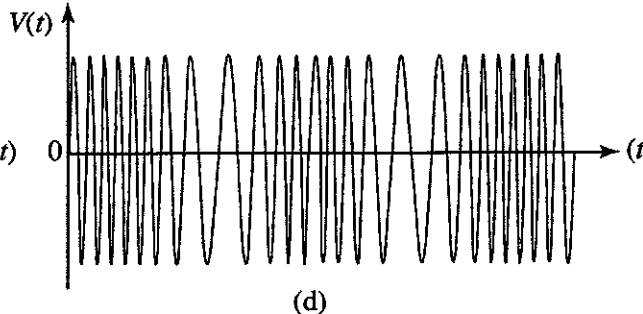
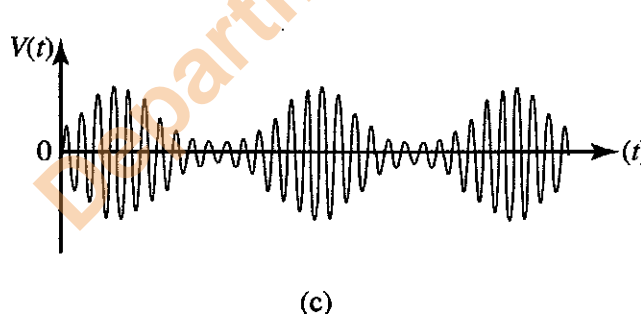
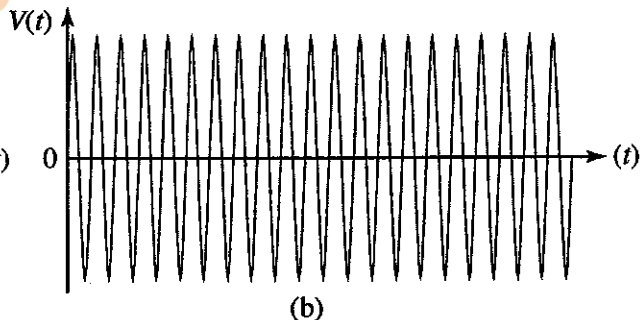
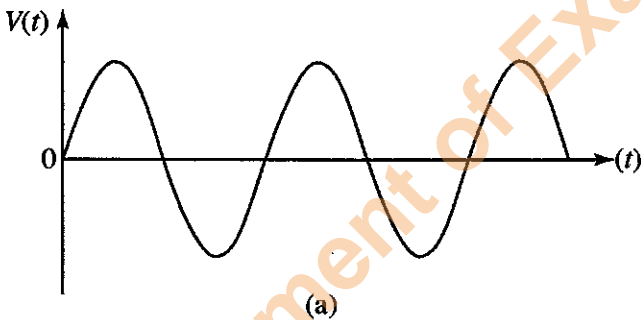

- Signal, carrier, amplitude modulated wave and frequency modulated wave are respectively shown by
- (1) a, b, c and d.
 - (2) b, c, a and d.
 - (3) b, a, d and c.
 - (4) b, a, c and d.
 - (5) a, b, d and c.

Department of Examinations Sri Lanka

Department of Examinations Sri Lanka

Department of Examinations Sri Lanka

ලංකා විභාග දෙපාර්තමේන්තුව ශ්‍රී ලංකා විභාග දෙපාර්තමේන්තුව ශ්‍රී ලංකා විභාග දෙපාර්තමේන්තුව ශ්‍රී ලංකා විභාග දෙපාර්තමේන්තුව ශ්‍රී ලංකා විභාග දෙපාර්තමේන්තුව
 இலங்கைப் பரீட்சைத் திணைக்களம் இலங்கைப் பரීட்சைத் திணைக்களம் இலங்கைப் பரීட்சைத் திணைக்களம் இலங்கைப் பரීட்சைத் திணைக்களம் இலங்கைப் பரීட்சைத் திணைக்களம்
 Department of Examinations, Sri Lanka Department of Examinations, Sri Lanka Department of Examinations, Sri Lanka Department of Examinations, Sri Lanka Department of Examinations, Sri Lanka
 இலங்கைப் பரීட்சைத் திணைக்களம் இலங்கைப் பரීட்சைத் திணைக்களம் இலங்கைப் பரීட்சைத் திணைக்களம் இலங்கைப் பரීட்சைத் திணைக்களம் இலங்கைப் பரීட்சைத் திணைக்களம்
 Department of Examinations, Sri Lanka Department of Examinations, Sri Lanka Department of Examinations, Sri Lanka Department of Examinations, Sri Lanka Department of Examinations, Sri Lanka

දෙවන පෙළ භාෂිත පත්‍ර (පස් පෙළ) විභාග, 2016 අගෝස්තු
සਲකිට් පොතුවේ තුන්වන පිටුව (2-වන තුරු) පරීட்சා, 2016 ඔක්තෝබර්
General Certificate of Education (Adv. Level) Examination, August 2016

ඉංජිනේරු තාක්ෂණවේදය II பொறியியற் தொழினுட்பவியல் II Engineering Technology II	65	E	II	පැය තුනයි மூன்று மணித்தியாலம் Three hours
---	-----------	----------	-----------	--

Index No. :

Important :

- * This question paper comprises of four parts, A, B, C and D. The total time allotted for all four parts is three hours.
- * Use of calculators is not allowed.

PART A – Structured Essay :
 (pages 2 - 8)

Answer all the questions on the question paper itself. Write your answers in the space provided for each question. Note that the space provided is sufficient for the answers and that extensive answers are not expected.

PARTS B, C and D – Essay :
 (pages 9 - 13)

Essay question paper contains six questions, Answer four questions selecting at least one question from each part. Use the papers supplied for this purpose.

At the end of the time allotted for this paper, tie the four parts A, B, C and D together as a single answer script so that Part A is on top and hand it over to the supervisor.

For Examiners' Use Only

65 - Engineering Technology II		
Part	Question Nos.	Marks Awarded
A	1	
	2	
	3	
	4	
B	5	
	6	
C	7	
	8	
D	9	
	10	
Total		
Percentage		

Final Marks	
In numbers	
In words	

Code Numbers	
Marking Examiner 1	
Marking Examiner 2	
Marks checked by	
Supervised by	

Department of Examinations Sri Lanka

PART A – Structured Essay

Answer **all four** questions on this paper itself.
(Marks allocated for each question is **60**.)

1. What is shown below is an isometric view of a wooden support having a 16 mm diameter hole in the base and a wedge as shown. According to the dimensions given, draw the front elevation (in the direction of arrow **A**), the side elevation (in the direction of arrow **B**) and the plan on the grid provided using the method of third angle orthogonal projection. Take one small square in the grid as 1 mm × 1 mm. The scale to be used is 1 : 1. All dimensions are in millimetres. Complete the data table assuming that this technical drawing has been drawn by Mr. Kumara of Sachintha Industrial Institute on 02.08.2016 and checked by Ms. Mallika on 04.08.2016 as drawing number ET/65/02. (The figure has not been drawn to scale.)

Do not write in this column

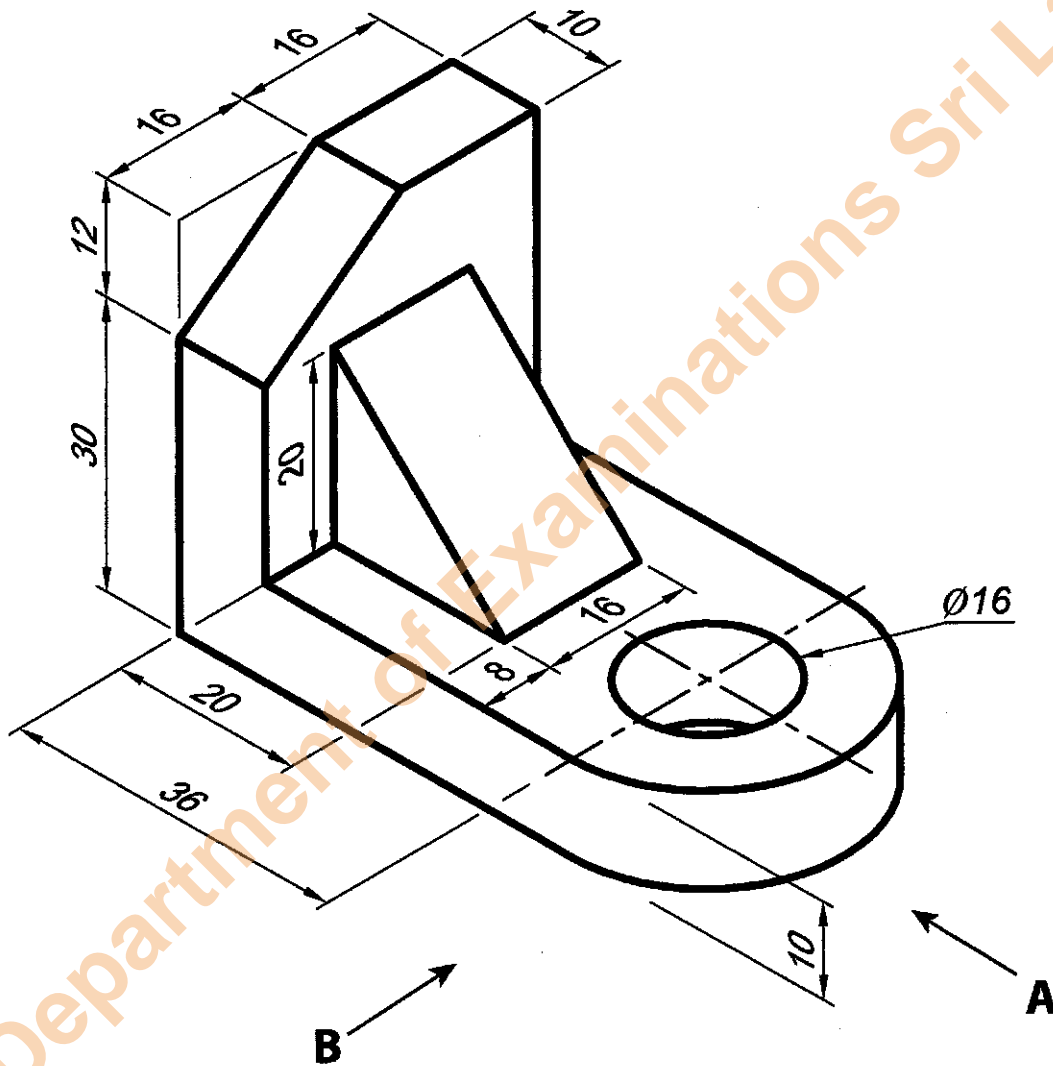

Q.1

60



Do not write in this column

2. Figure X shows a rough plan of a proposed cricket stadium. Figure Y shows a cross section of its main pavilion.

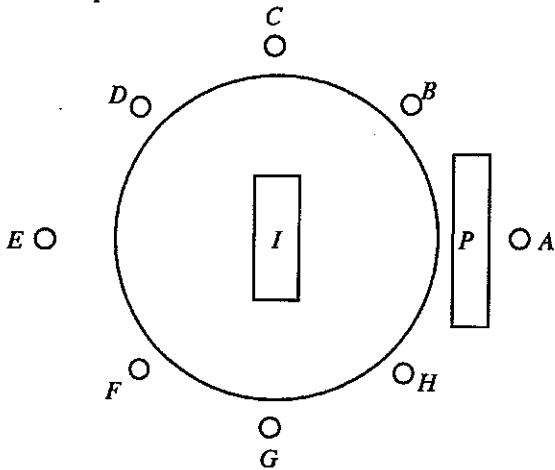

Figure X

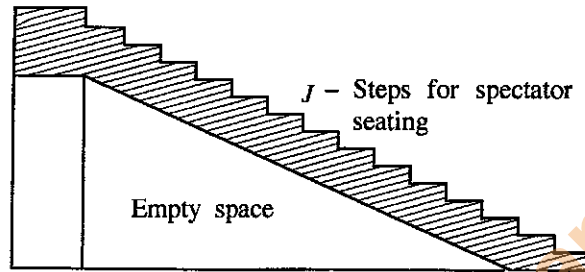

Figure Y

P - Pavilion

A - H - Flood light posts

I - Pitch

(a) For the section that includes the steps for seating of the spectators in the pavilion P, a concrete volume of 280 m^3 is needed according to calculations. The recommended ratio of concrete mixture is 1 : 2 : 4. It is necessary to have 1.5 m^3 of dry material in order to obtain 1 m^3 of wet concrete. Calculate the required volumes in cubic meters for the following materials.

(1) Sand :

(2) Metal/aggregate :

(08 × 2 = 16 marks)

(b) The stadium requires 36 kWh of electrical energy during the day time. It has been decided to supply this using solar cell panels. In practical circumstances the efficiency of a solar cell panel is 10% and the available average amount of solar energy is 6 kWh/m^2 per day. How many square metres of solar cell panels are needed in order to supply the required electrical energy?

.....

(04 marks)

(c) The pitch (I) at the centre of the playground is designed to have a rectangular shape. State two methods that can be simply used in order to mark one corner of the rectangular shape.

(1)

(2)

(02 × 2 = 04 marks)

(d) State an equipment/tool that can be used to ensure whether the flood light posts are vertical.

.....
 (02 marks)

(e) It has been proposed to install an overhead tank and a pipe system to distribute and supply water to the playground. State two factors that govern the rate of flow of water to the playground that need to be considered when designing the water system.

(1)

(2)

(02 × 2 = 04 marks)

Do not write in this column

(f) Steps shown by J need to be constructed to facilitate the spectators to sit and watch cricket. What are the deciding factors that determine the height of the steps?

(1)

(2)

(03 x 2 = 06 marks)

(g) It has been decided to have 8 flood light posts to facilitate playing at night. Each of the posts requires 10 kW of power. In order to supply electricity for these, it has been decided to use a diesel electric generator.

(i) What is the minimum capacity that the electric generator should have?

.....

(04 marks)

(ii) For increasing the reliability of the electric generator system, write one step each that can be taken at the stages mentioned below.

(1) Design stage :

(2) Operation stage :

(04 x 2 = 08 marks)

(iii) Write four different health and safety risks that are there when operating this electric generator.

(1)

(2)

(3)

(4)

(03 x 4 = 12 marks)

Q.2

60

3. (a) (i) Manufacture of square plates instead of circular plates can be considered as a turning point in the ceramic industry. State the technological factors, which led to this.

(1) Factor related to production technology :

.....

(2) Factor related to materials technology :

.....

(04 x 2 = 08 marks)

(ii) Even though electric vehicles that use only a battery and a motor are considered as having 'zero emission', this is not a fact. State two arguments based on everyday use of electric vehicles in order to justify the above statement.

(1)

(2)

(04 x 2 = 08 marks)

(b) (i) Write two accidents that may cause risks to life which can be displayed on a notice board to warn machine operators of a machine shop.

(1)

(2)

(04 x 2 = 08 marks)

(ii) State two precautions taken during the design of production machinery in order to prevent accidents.

(1)

(2)

(04 x 2 = 08 marks)

Do not write in this column

(iii) State **two** musculoskeletal disorders that may result from working for a long time in a machine shop and give one causative factor for each.

Disorder	Causative factor
(1)
(2)

(04 × 4 = 16 marks)

(c) The linear graph shown in the figure below was obtained when calibrating an Ohm meter.

When a resistance was measured using this Ohm meter, a reading of 50 Ω was shown. What is the real value of the resistance?

.....

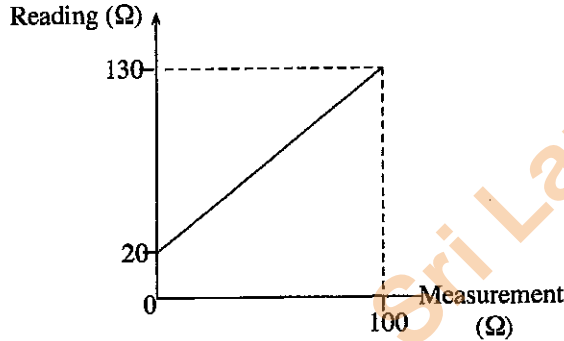

(12 marks)

Q. 3

60

4. (a) Mr. Sachintha operates a business for manufacturing and selling television antennas under the brand name 'EXP' in his own factory. His main market is in urban areas. Presently the sale of television antennas has been decreasing in these areas as a result of new technologies such as internet television popularizing. However, the sale of television antennas is still increasing in rural areas.

There are twenty experienced employees working in his business and six employees out of them have been assigned for selling activities. Mr. Sachintha trusts these employees to such an extent that he does not inquire the reasons for the decreases in sales for the months when sales are low. Mr. Sachintha operates his business by directing and motivating his employees properly and assigning duties and authorities to them. Sales employees have been given sole authority to collect money and also allowed to keep the remaining stocks under their custody. Mr. Sachintha does not have a clear idea about the profit that he should earn from his business.

Answer the following questions relating to the above passage.

(i) State **two** leadership qualities Mr. Sachintha has.

(1)

(2)

(04 marks)

(ii) Name **two** management functions that Mr. Sachintha has **not** practised properly and name **one** action each that can be taken by him to manage his business properly.

Function	Action
(1)
(2)

(08 marks)

(iii) Write one strength, weakness, opportunity and a threat in relation to Mr. Sachintha's business.

Item	Description
Strength
Weakness
Opportunity
Threat

(08 marks)

Do not write in this column

(iv) State **two** benefits of developing a marketing plan in order to overcome marketing weaknesses in Mr. Sachinta's business.

- (1)
-
- (2)
-

(04 marks)

(v) Give **two** factors which need attention by Mr. Sachintha for ethically dealing with his customers.

- (1)
- (2)

(04 marks)

(b) (i) The table below shows the market demand and supply information for the products of Mr. Sachintha's business.

Price (Rs.)	Demand (Units)	Supply (Units)
1800	1000	200
2000	800	400
2200	600	600
2400	400	800
2600	200	1000

(1) At what price will market equilibrium occur?

-

(02 marks)

(2) What is the reason for the market equilibrium to occur at that price?

-
-

(02 marks)

(ii) State **two** strategies that Mr. Sachintha can take for increasing the number of 'EXP' antennas sold.

- (1)
- (2)

(04 marks)

(iii) State **two** factors that Mr. Sachintha should consider when deciding on the supply of 'EXP' antennas.

- (1)
- (2)

(04 marks)

Do not write in this column

(c) Mr. Sachintha is able to produce either 'EXP' television antennas or 'PLX' antennas with improved technology. Information relevant to these products are shown in the table given below.

Description	EXP	PLX
Fixed cost	Rs. 90 000	Rs. 130 000
Unit cost of selling	Rs. 700	Rs. 1 000
Unit selling price	Rs. 1 800	Rs. 2 200
Unit variable cost	Rs. 600	Rs. 900
Number of expected sales units	5 000	5 250

(i) Calculate the gross profit per unit for each type of the antennas.

Description	EXP	PLX
Gross profit		

(04 marks)

(ii) Calculate and show which type of antenna out of the above two will give higher expected sales income to Mr. Sachintha.

.....

.....

.....

.....

(04 marks)

(iii) Calculate the break-even point for each of the antennas by showing the steps of the calculation.
EXP

.....

.....

.....

.....

(04 marks)

PLX

.....

.....

.....

.....

(04 marks)

(iv) List **two** micro-environmental factors that Mr. Sachintha should consider in addition to the expected income in deciding on the type of television antenna to produce out of the two.

- (1)
- (2)

(04 marks)

* * *

Q. 4

60

Department of Examinations Sri Lanka

ශ්‍රී ලංකා විභාග දෙපාර්තමේන්තුව ශ්‍රී ලංකා විභාග දෙපාර්තමේන්තුව ශ්‍රී ලංකා විභාග දෙපාර්තමේන්තුව ශ්‍රී ලංකා විභාග දෙපාර්තමේන්තුව ශ්‍රී ලංකා විභාග දෙපාර්තමේන්තුව
 இலங்கைப் பரீட்சைத் திணைக்களம் இலங்கைப் பரීட்சைத் திணைக்களம் இலங்கைப் பரීட்சைத் திணைக்களம் இலங்கைப் பரීட்சைத் திணைக்களம் இலங்கைப் பரීட்சைத் திணைக்களம்
 Department of Examinations, Sri Lanka Department of Examinations, Sri Lanka Department of Examinations, Sri Lanka Department of Examinations, Sri Lanka Department of Examinations, Sri Lanka

අධ්‍යයන පොදු සාහිත්‍ය පත්‍ර (උසස් පෙළ) විභාගය, 2016 අගෝස්තු
 கல்விப் பொதுத் தராதரப் பத்திர (உயர் தர)ப் பரீட்சை, 2016 ஆகஸ்ட்
 General Certificate of Education (Adv. Level) Examination, August 2016

ඉංජිනේරු තාක්ෂණවේදය II
 பொறியியற் தொழினுட்பவியல் II
 Engineering Technology II

65 E II

Instructions:

- * Answer four questions only selecting at least one question each from parts B, C and D.
- * Marks allocated for each question is 90.

Part B - Essay (Civil Technology)

5. (a) Answer the following questions based on the lintels and cantilever concrete structures given in the figures.

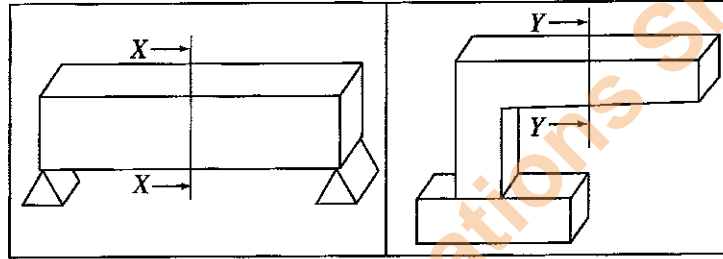

- (i) Draw the plane cross-sections X-X and Y-Y and indicate neutral zones. (04 marks)
 - (ii) In each of the above cross-sections indicate tensile and compressive zones. (08 marks)
 - (iii) Indicate the positions of the reinforcements in each of the cross-sections. (08 marks)
 - (iv) Explain the importance of reinforcements giving two reasons. (08 marks)
- (b) Write two factors that influence the length of overlap used in reinforcement bars for concrete. (08 marks)
- (c) Describe using an example two benefits of using pre-stressed concrete. (08 marks)
- (d) (i) Explain the importance of compaction process in laying concrete. (08 marks)
 (ii) Explain how over-compaction affects the quality of concrete. (08 marks)
- (e) Sketch a normal strip foundation and label any three parts. (08 marks)
- (f) It is required to construct a double roof for a workshop.
- (i) Describe with examples the main factors to be considered in determining the areas of cross-section of struts, posts etc. used for constructing the roof. (10 marks)
 - (ii) It is necessary to increase the span of the roof since the activities of the workshop have expanded. Explain why timber will be unsuitable to be used for the roof, if partition walls or columns are not to be used. (10 marks)
 - (iii) Name two materials that are suitable for the roof structure instead of timber. (02 marks)

6. Water becomes unsuitable for consumption when contaminated with various pollutants. The process of removing such harmful chemicals and other substances from water is important, and known as purification of water. After this process water is sent to storage tanks and then distributed to the consumers through distribution pipe systems.

- (a) Describe the main steps of water purification. (10 marks)
- (b) State the basic functions performed by the following components of water supply systems and sewage disposal systems.
- Taps
 - Valves
 - Water trap
 - Septic tank
 - Manhole
- (15 marks)
- (c) Describe the way the water hammer is created. (10 marks)
- (d) Given below are the level readings obtained in a levelling work using only one levelling instrument station for an area where it has been proposed to distribute water using a pipe network.

Levelling station	Reading (m)	Description
1	2.5	A
2	1.4	B
3	0.5	C
4	3.0	D
5	1.8	E
6	0.7	F

- (i) If the reduced level of the levelling station A is 100 m, calculate the reduced level of each of the other stations using a table based on the rise and fall method. (40 marks)
- (ii) Describe **three** errors that can occur in the levelling process. (09 marks)
- (iii) Describe **two** precautions that can be taken for minimising the above errors. (06 marks)

Part C - Essay (Mechanical Technology)

7. (a) A diesel fuelled, four stroke, inline engine has four cylinders. Based on this engine, explain how the four-stroke cycle is practically used in engines. (35 marks)
- (b) Compression ignition engines are preferred to spark ignition engines for heavy duty vehicles. Explain the main reason for this. (25 marks)
- (c) Excessive black smoke emission is a common problem in diesel engines. Explain **two** scientific reasons for the production of black smoke inside engines. (10 marks)
- (d) Give **two** mechanical faults causing this black smoke, inside engines. (10 marks)
- (e) In automotive cooling systems in engine, centrifugal pumps are often used instead of positive displacement pumps. Explain **two** reasons for this. (10 marks)

8. The figure shows the front elevation and the plan of an assembly which has been proposed for installing a 4 m high lamp post. It has two parts *A* and *B*. Part *A* is a square box steel channel which can hold the lamp post. The base *B* requires 4 holes as shown in the figure for fixing to the ground. You have been supplied with a 40 cm long box steel channel of cross-section 20 cm \times 20 cm and a steel plate of 10 mm thickness and size 70 cm \times 70 cm. (The figure is **not** to scale and the diagram is a sketch.)

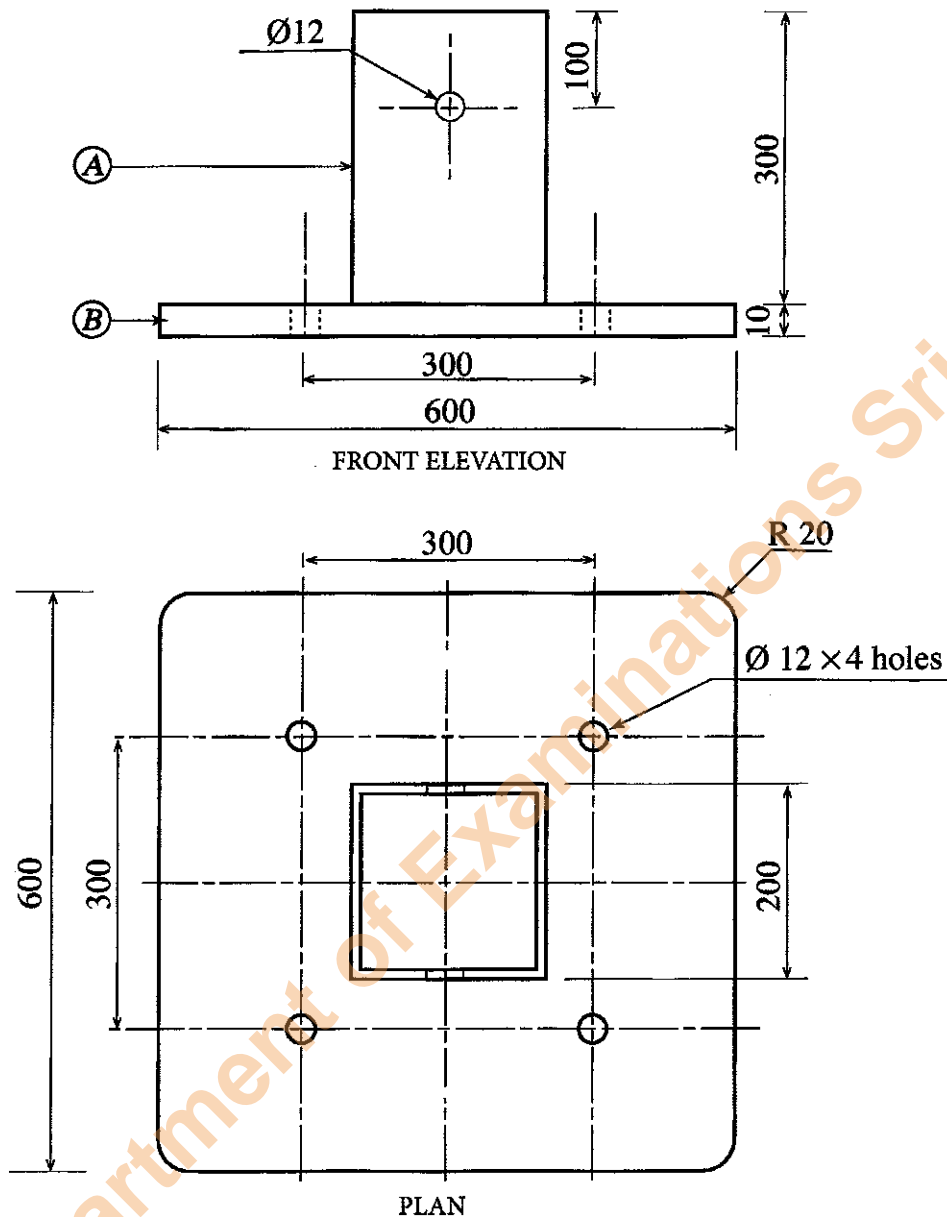

- Show the most suitable sequence of steps from the beginning for measuring off, marking out and preparing the flat steel plate for the base of the assembly. (25 marks)
- Show the sequence of steps from the beginning for measuring off, marking out and cutting off the box steel channel part for the assembly as shown in the diagram. (25 marks)
- Explain the way to assemble flat steel base and box steel part. (20 marks)
- Explain the method of completing and finishing the assembly. (10 marks)
- When in use it is possible that water will collect inside the box steel channel of the assembly part. Suggest a way to design the assembly to allow water to drain out. (10 marks)

Part D - Essay (Electrical and Electronic Technology)

9. (a) (i) State the right-hand rule for electro magnetic induction. (03 marks)
- (ii) In direct current motors field and armature windings are connected in three different ways for constructing series wound, shunt wound and compound wound motors. Draw the circuit diagrams for series wound, shunt wound and compound wound motors and indicate the way the field and armature windings are connected. (12 marks)
- (iii) Show graphically the relationship between the speed and armature current of series wound and shunt wound motors. (05 marks)
- (iv) State **one** example each for the application of direct current series wound motors and shunt wound motors and explain the reasons for such use. (05 marks)
- (b) (i) Write down the expression indicating the relationship among the voltages, number of turns and current in the primary and secondary windings of a lossless transformer. (03 marks)
- (ii) Domestic washing machine which has been used in a foreign country has been brought to this country. This machine draws a current of 5 A when it is working at maximum power when connected to an alternating current supply of 110 V and 50 Hz. It is required to install and operate this machine on Sri Lankan domestic electrical system.
- (A) State the type of transformer to be used for this. (02 marks)
- (B) If the transformer chosen has 50 turns in its secondary winding, calculate the number of turns required in the primary winding and the current flowing in the primary winding when the machine is operating at its maximum power. (Assume that the transformer is lossless.) (10 marks)
- (c) (i) It is required to make a line of electric bulbs for a decoration with 15 bulbs of 12 V, 24 W connected in series. The line of bulbs is to be connected to a 240 V 50 Hz alternating current supply. Calculate the value of the resistance to be connected in series to prevent the current through the bulbs exceeding their rated current. (10 marks)
- (ii) It is required to operate the electric lamp inside the living room of a house using two-way switches from outside the house as well as from inside the living room. Draw a wiring diagram for this using standard symbols. (10 marks)
- (d) The tariff structure which is used for preparing domestic electricity bills is shown below.

Monthly consumption units (kWh)	Unit price (Rs. per kWh)	Fixed monthly rate (Rs/month)
0 - 60	7.85	30.00
61 - 90	10.00	90.00
91 - 120	27.75	480.00
121 - 180	32.00	480.00
more than 180 units	45.00	540.00

The number of electricity units used during 30 days in your house is 95. You have received a bill of Rs. 1386.75 for this. A relative of yours who came to know about this advised you to use a pedestal fan of power 60 W instead of the ceiling fan of power 100 W in your bed room. Assume that the fan is used 8 hours per day and there is no change in the use of the other appliances.

- (i) How many electricity units can be saved in a month of 30 days by following this advice? (10 marks)
- (ii) Compute the new electricity bill for a 30-day month. (10 marks)
- (iii) How much money can you save in a month following the advice? (05 marks)
- (iv) If you had to spend Rs. 6000/= for buying the new fan, calculate the time required to recover the spent money. (05 marks)

10. (a) Following figure shows a fixed biased transistor circuit.

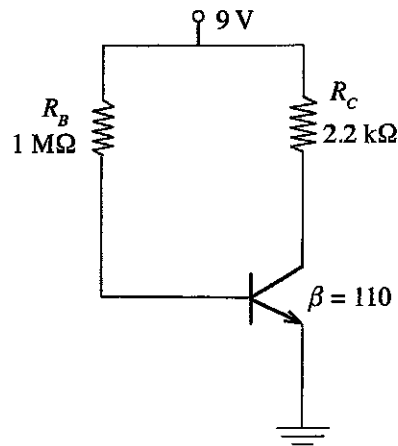

According to above circuit, calculate the following.

- (i) Collector current (I_C) (10 marks)
 - (ii) Collector emitter voltage (V_{CE}) (10 marks)
- (b) The fixed bias resistor (R_B) in the above circuit is replaced by a $1\text{ M}\Omega$ variable resistor.
- (i) Express the relationship between collector current (I_C) and base current (I_B) mathematically when the transistor works in the saturation region. (05 marks)
 - (ii) Calculate the maximum resistance of the variable resistor that causes the transistor saturation. (Assume collector emitter saturation voltage $V_{CE(SAT)}$ is 0.2 V) (20 marks)
 - (iii) If the resistance of the variable resistor becomes zero (0), explain how it affects the transistor operation. (05 marks)
- (c) In addition to the biasing shown in the above circuit illustrate using separate circuit diagrams **two** other methods for biasing a transistor. (10 marks)
- (d) Explain using a circuit diagram how the above circuit can be modified to safely, vary the brightness of a Light Emitting Diode (LED). (Assume that the supply voltage is 9 V , the voltage drop across the LED is 2.1 V and the maximum current through the LED is 100 mA .) The values of all fixed resistors should be calculated. (30 marks)

Department of Examinations Sri Lanka

Department of Examinations Sri Lanka