

සියලු ම හිමිකම් ඇවිරිණි / முழுப் பதிப்புரிமையுடையது / All Rights Reserved]

ශ්‍රී ලංකා විභාග දෙපාර්තමේන්තුව ශ්‍රී ලංකා විභාග දෙපාර්තමේන්තුව ශ්‍රී ලංකා විභාග දෙපාර්තමේන්තුව ශ්‍රී ලංකා විභාග දෙපාර්තමේන්තුව ශ්‍රී ලංකා විභාග දෙපාර්තමේන්තුව
இலங்கைப் பரீட்சைத் திணைக்களம் இலங்கைப் பரීட்சைத் திணைக்களம் இலங்கைப் பரීட்சைத் திணைக்களம் இலங்கைப் பரීட்சைத் திணைக்களம் இலங்கைப் பரීட்சைத் திணைக்களம்
Department of Examinations, Sri Lanka Department of Examinations, Sri Lanka Department of Examinations, Sri Lanka Department of Examinations, Sri Lanka Department of Examinations, Sri Lanka

අධ්‍යයන පොදු සහතික පත්‍ර (උසස් පෙළ) විභාග, 2016 අගෝස්තු
கல்விப் பொதுத் தராதரப் பத்திர (உயர் தர)ப் பரீட்சை, 2016 - ஆகஸ்ட்
General Certificate of Education (Adv. Level) Examination, August 2016

යාන්ත්‍රික තාක්ෂණවේදය I
பொறிமுறைத் தொழினுட்பவியல் I
Mechanical Technology I

15 E I

පැය දෙකයි
இரண்டு மணித்தியாலம்
Two hours

Instructions:

- * Answer **all** the questions.
- * Write your **Index Number** in the space provided in the answer sheet.
- * Use of calculators is not allowed.
- * Instructions are given on the back of the answer sheet. Follow those carefully.
- * In each of the questions 1 to 50, pick one of the alternatives from (1), (2), (3), (4), (5) which is **correct** or **most appropriate** and mark your response on the answer sheet with a cross (x) in accordance with the instructions given in the back of the answer sheet.

1. The drag force acting on a free falling sphere in a fluid, is expressed as $F = 6\pi\eta aV$, where a is the sphere radius, V is the terminal velocity and η is the absolute viscosity. The SI units of η are
(1) Pa.s (2) Poise (3) m^2s^{-1} (4) m^2s (5) Nm
2. Density of water at room temperature is found to be 62.4 lbf/ft^3 . Unit weight of water is given as 9.81 kN/m^3 . 1 psi pressure is equal to
(1) 1.0 kPa (2) 4.1 kPa (3) 5.8 kPa (4) 6.9 kPa (5) 7.2 kPa
3. Certain safety measures for cyclists are suggested below.
A - Adjust seat to ensure comfort and efficient pedalling.
B - Check to ensure uneven wear in brake shoes.
C - Determine tyre pressure based on the weight of rider.
D - Use a side mirror to look behind, before changing course.
As a cyclist, which safety measures you would consider taking in order to prevent injury during riding?
(1) A, B and C only. (2) A, B and D only. (3) A, C and D only.
(4) B, C and D only. (5) A, B, C and D all.
4. Alum is a chemical compound used in swimming pools and water purification plants. The specific compound of hydrated Potassium Aluminium Sulphate (ie. Potassium Alum) has the formula $KAl(SO_4)_2 \cdot 12H_2O$. Consider the following statements regarding Alum:
A - It is a crystallized solid at room temperature.
B - It is used in water purification, in order to cause negatively charged particles to flocculate.
C - It also acts as a disinfectant that removes bacteria from water.
D - It is highly soluble in water.
Which of the above statements are true?
(1) A, B and C only. (2) A, B and D only. (3) A, C and D only.
(4) B, C and D only. (5) A, B, C and D all.
5. A person has purchased a three-wheeler on credit obtained from a finance company. He intends to serve his semi-urban community, and a few retail outlets in his neighbourhood. Which of the following decisions demonstrate his entrepreneurship traits?
A - Serve two regular customers to transport their children to the National school (Destination being 3 km away).
B - Use mobile phone to network with fellow drivers
C - Offer a discounted rate to regular customers
D - Use mobile phone to secure night-time hires
(1) A, B and C only. (2) A, B and D only. (3) A, C and D only.
(4) B, C and D only. (5) A, B, C and D all.

6. Select the correct elevation of the object when looking from direction A.

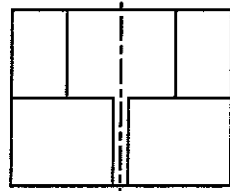

(1)



(2)

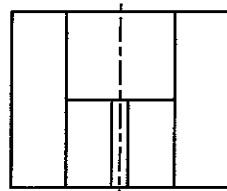

(3)

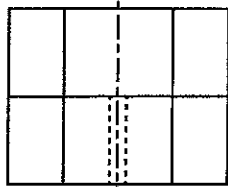
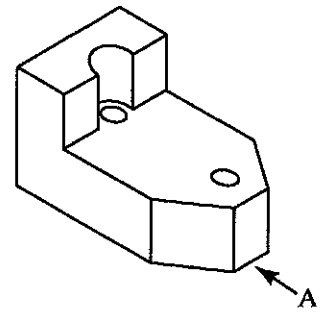

(4)

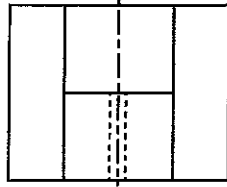

(5)

7. Figures 1 and 2 show velocity-time graphs for two projections of a ball. Select the response which gives the most relevant projection. Neglect the air resistance and other relevant resistances.

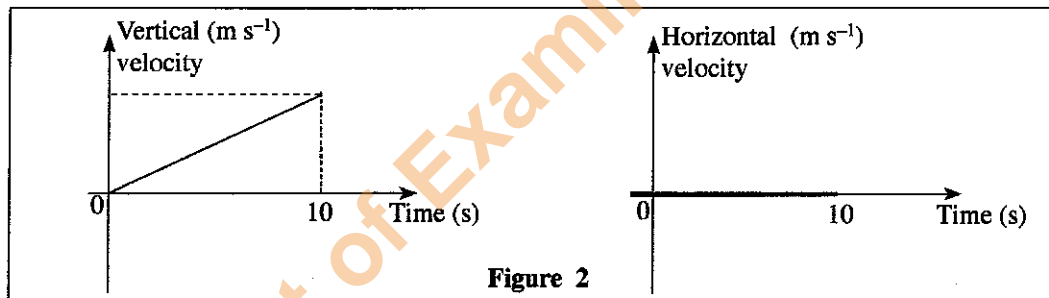
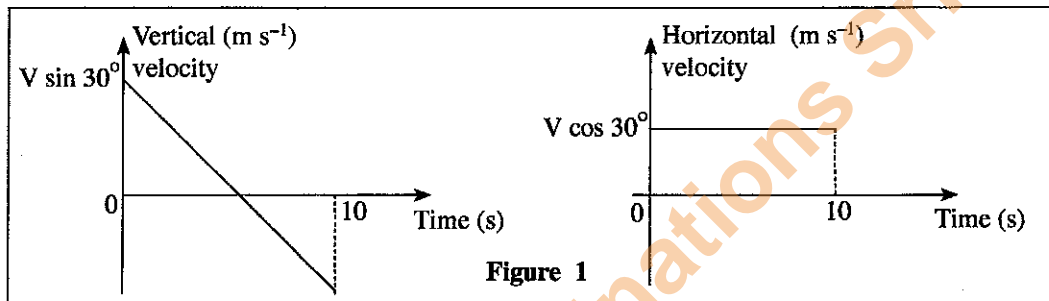

| | Figure 1 | Figure 2 |
|-----|---|---|
| (1) | Projection of a ball from velocity V at an angle 30° to a horizontal plane | Projection of a ball along a horizontal plane |
| (2) | Projection of a ball along a vertical plane in upward direction | Projection of a ball from velocity V at an angle 30° to a vertical plane |
| (3) | Projection of a ball from velocity V at an angle 30° to a horizontal plane | Drop a ball along a vertical plane from a height |
| (4) | Drop a ball along a vertical plane from a height | Projection of a ball along a horizontal plane |
| (5) | Projection of a ball from velocity V at an angle 30° to a vertical plane | Drop a ball along a vertical plane from a height |

8. Wind and tidal waves are used in turbines and generator sets to convert one form of energy to another. Select the correct energy conversion involved in the process.

- | | |
|---|--|
| (1) Mechanical energy \rightarrow electrical energy | (2) Kinetic energy \rightarrow electrical energy |
| (3) Potential energy \rightarrow kinetic energy | (4) Potential energy \rightarrow electrical energy |
| (5) Chemical energy \rightarrow electrical energy | |

9. Which of the following statements is true about the law of conservation of energy?
- (1) Energy cannot be created nor destroyed, but it can be converted from one form to another.
 - (2) Energy can be created or destroyed, but it cannot be converted from one form to another.
 - (3) Energy cannot be created nor destroyed, nor can it be converted from one form to another.
 - (4) Energy can be created or destroyed, and it can also be converted from one form to another.
 - (5) Energy can be created but cannot be destroyed.
10. Which of the following options given below correctly shows the energy changes involved when a television is on?
- (1) Electrical energy \rightarrow Light and Sound energy \rightarrow Thermal energy
 - (2) Electrical energy \rightarrow Thermal energy \rightarrow Light and Sound energy
 - (3) Light and Sound energy \rightarrow Thermal energy \rightarrow Electrical energy
 - (4) Thermal energy \rightarrow Light and Sound energy \rightarrow Electrical energy
 - (5) Thermal energy \rightarrow Electrical energy \rightarrow Light and Sound energy
11. Select the proper optical arrangement for the reflector of a front head lamp of a car.
- (1) Plane mirror (2) Plane glass (3) Concave mirror (4) Convex mirror (5) Lens arrangement
12. A 75 W incandescent lamp is installed in a house wiring circuit. It is switched on for 2 hours in the morning and for 6 hours at night. Owner decided to replace the 75 W incandescent lamp with a 15 W CFL lamp to reduce power consumption. What is the expected saving in daily power consumption?
- (1) 480 kWh (2) 48 kWh (3) 0.48 kWh (4) 600 kWh (5) 0.6 kWh
13. A bipolar junction transistor is tested to identify whether it is working or faulty. A multimeter is switched to ohm scale and the positive testing probe is connected to the base and the negative testing probe is connected to the emitter. Then a low resistance is displayed. After interchanging the probes, a high resistance is shown. Consider the following conclusions regarding the transistor.
- A - It is a NPN type transistor
 - B - It is a PNP type transistor
 - C - Base-emitter junction is broken
 - D - Base-emitter junction is in good condition
 - E - Data are not sufficient to reach any conclusion.
- Select the most accurate statement/s.
- (1) A and C only. (2) B and D only. (3) A and D only.
 - (4) B and C only. (5) E only.

14. What is the equivalent resistance and standard power values for one equivalent resistor which can be used between A and B, instead of the resistor bank?

- (1) 200 k Ω / 2W
- (2) 50 k Ω / 1W
- (3) 50 k Ω / 2W
- (4) 20 k Ω / 2W
- (5) 120 k Ω / 2W

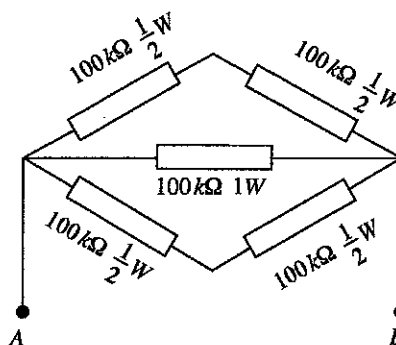

15. A, B and C circuits given below are used for an amplifier. Select the circuit/s which can protect the amplifier when supply connections are interchanged.

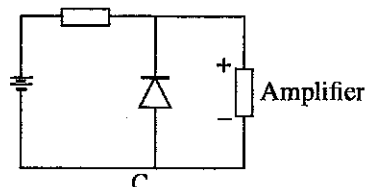
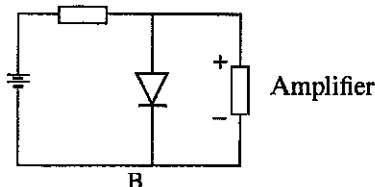
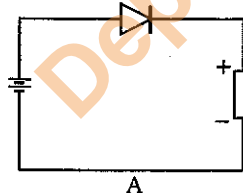

- (1) A only (2) A and B only (3) A and C only
- (4) B and C only (5) A, B and C all

16. What is the symbol used for a logic gate with an output logic state equal to 0, only when logic states of all inputs are equal to zero?

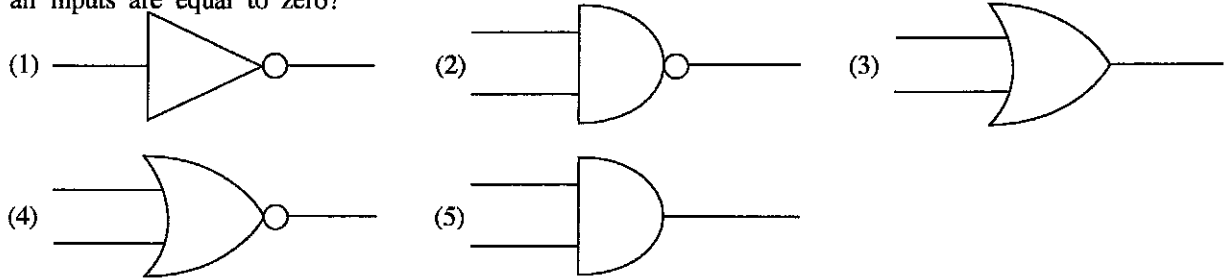

17. Consider the following circuit arrangements. Select the option that gives the ascending order of ammeter readings.

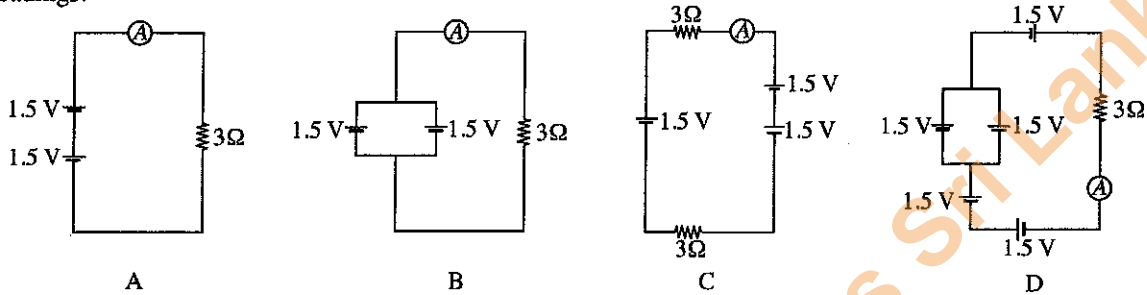

- (1) C, B, A, D (2) A, B, C, D (3) A, B, D, C (4) D, C, B, A (5) C, A, B, D

18. Select the option which gives the correct symbols for electronic components given below in corresponding order from A to E.

- A - NPN transistor B - PNP transistor C - Diode
D - Capacitor E - Light emitting diode

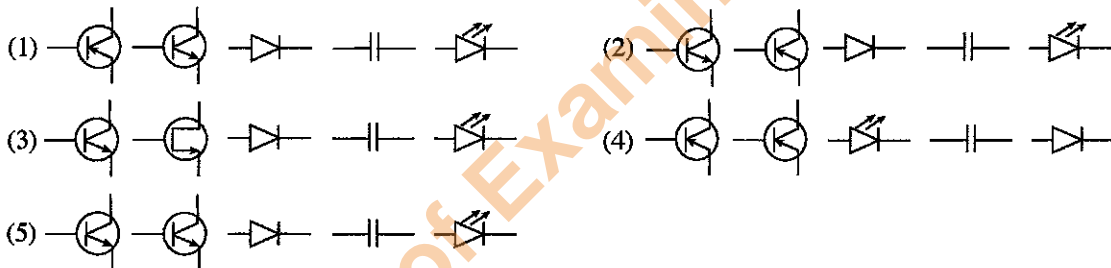

19. Which one of the following best describe the relationship between the buoyancy force of an object submerged in a fluid?

- (1) The buoyancy force is equal to the mass of the object.
 (2) The buoyancy force is equal to the weight of the fluid.
 (3) The buoyancy force is equal to the mass of the fluid that the object displaces.
 (4) The buoyancy force is equal to the weight of the fluid that the object displaces.
 (5) The buoyancy force is equal to the density of the fluid.

20. When an aeroplane is taking off passengers inside the cabin may feel a pain in their ears. This can be due to

- A - Air pressure reduction with increasing altitude.
 B - Sound of the engine of the aeroplane.
 C - Temperature increase with increasing altitude.
 D - Reduction of the density of air with increasing altitude.
 (1) A only. (2) B only. (3) A and C only. (4) A and D only. (5) B and C only.

• Answer the following questions 21 and 22, assuming $g = 10 \text{ m/s}^2$.

21. A train engine reaches a speed of 36 kmh^{-1} from zero velocity within 5 seconds. It weights 120 tons and the friction coefficient between its wheels and the rail track is 0.4. The generated frictional resistance is

- (1) 12 kN (2) 120 kN (3) 48 kN (4) 480 kN (5) 960 kN

22. The force generated from the engine described in question 21 is

- (1) 480 kN (2) 240 kN (3) 270 kN
 (4) 232 kN (5) 720 kN

23. 360 kg weight is lifted through a frictionless pulley arrangement as shown in the figure. The force to be applied at P would be

- (1) 60 kg
 (2) 120 kg
 (3) 40 kg
 (4) 80 kg
 (5) 150 kg

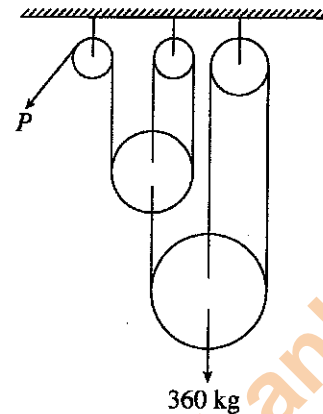

24. What are the correct statements regarding the friction force?

- A - The friction force between two surfaces can be increased by increasing the surface areas.
 B - The friction force between two surfaces can be changed by changing the roughness of each surface.
 C - The friction force is used in automobiles to carry out useful tasks.
 D - By changing the roughness of two surfaces, coefficient of friction between those surfaces can be changed.

- (1) A, B and C only. (2) A, B and D only. (3) A, C and D only.
 (4) B, C and D only. (5) A, B, C and D.

25. A measurement obtained from a vernier calliper is shown in the figure. What is its reading?

- (1) 3.16 cm
 (2) 2.40 cm
 (3) 2.16 cm
 (4) 4.80 cm
 (5) 2.46 cm

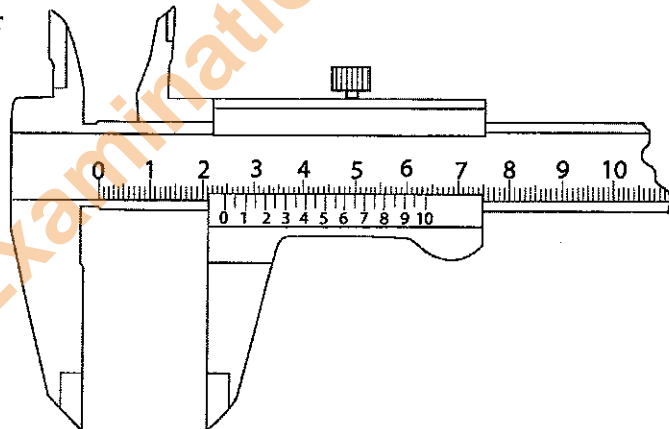

26. Gear is a toothed wheel that works with others to alter the relation between the speed of a driving mechanism (such as the engine of a vehicle) and the speed of the driven parts (the wheels). Select the gears that are used to connect two parallel shafts.

- A - Spur gears
 B - Helical gears
 C - Bevel gears
 D - Double helical gears

- (1) A, B and C only. (2) A, B and D only. (3) A, C and D only.
 (4) B, C and D only. (5) A, B, C and D all.

27. Which of the following device is **not** a direct measuring instrument?

- (1) Micrometer (2) Vernier calliper (3) Divider
 (4) Steel ruler (5) Measuring tape

28. What are the elements that should be controlled to obtain satisfactory welding operation in the arc welding?

- (1) Current, Voltage and Speed of travel.
 (2) Current, Voltage and Arc length.
 (3) Current, Arc length and Speed of travel.
 (4) Voltage, Arc length and Speed of travel.
 (5) Voltage, Arc length and Weld thickness.

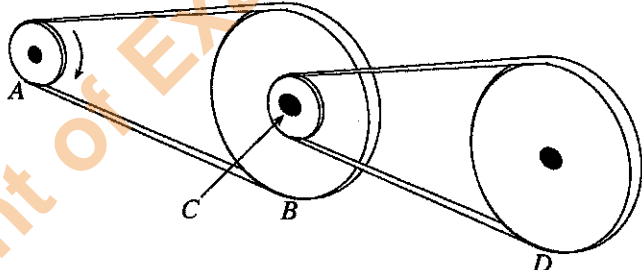
29. Fillet welding refers to the process of joining two pieces of metal together whether they are perpendicular or at an angle. Some of the welding joints are given below.
- A - Butt joint
B - Lap joint
C - T-joint
D - Corner joint
- Which of the welding joints are fillet weld?
- (1) A, B and C only. (2) A, B and D only. (3) A, C and D only.
(4) B, C and D only. (5) A, B C and D all.
30. In a motor vehicle the propulsion is provided by an engine or a motor. Consider the following statement regarding a vehicle.
- A - High torque is required at the start of the vehicle
B - Torque reduces at high speeds
C - Gearbox helps in smooth running of vehicle
- Which statement/s is/are correct?
- (1) A only (2) B only. (3) C only.
(4) A and B only. (5) A, B and C all.
31. Four statements regarding a gearbox is given below.
- A - A gear box is a mechanical method of transforming power from one device to another.
B - It can increase torque while reducing speed.
C - It can increase the power given by the prime mover while reducing speed.
D - Lubrications are normally used in a gearbox.
- What are the correct statements?
- (1) A, B and C only. (2) A, B and D only. (3) A, C and D only.
(4) B, C and D only. (5) A, B C and D all.
- Figure shows a power transmission system of a device. Pulley A rotates clockwise. Pulley B and C are connected to the same shaft. Diameters of pulley A, B, C and D are d , $3d$, $d/2$ and $2d$ respectively. Use the figure to answer questions 32 and 33.
32. Select the correct combination of rotational directions.
- 
- | B | C | D |
|--------------------|----------------|----------------|
| (1) Clockwise | Clockwise | Clockwise |
| (2) Anti-clockwise | Anti-clockwise | Anti-clockwise |
| (3) Clockwise | Anti-clockwise | Clockwise |
| (4) Anti-clockwise | Clockwise | Clockwise |
| (5) Clockwise | Clockwise | Anti-clockwise |
33. If the rotational speed of pulley A is ω what is the rotational speed of pulley C?
- (1) $\omega \times 3 \times \frac{1}{2}$ (2) $\frac{\omega \times 3}{\frac{1}{2}}$ (3) $\omega \times \frac{1}{3} \times 1$ (4) $\frac{\omega}{3 \times \frac{1}{2}}$ (5) $\frac{\omega}{\frac{1}{3} \times 1}$
34. What represents the input and the output of a temperature control system respectively?
- (1) The heating element and the temperature sensor.
(2) The actual temperature and heat produced.
(3) The heat produced by the system and the heating element.
(4) The desired temperature and the actual temperature.
(5) The temperature sensor and the desired temperature.

35. Following figure shows a boy adjusting temperature of water in a shower.

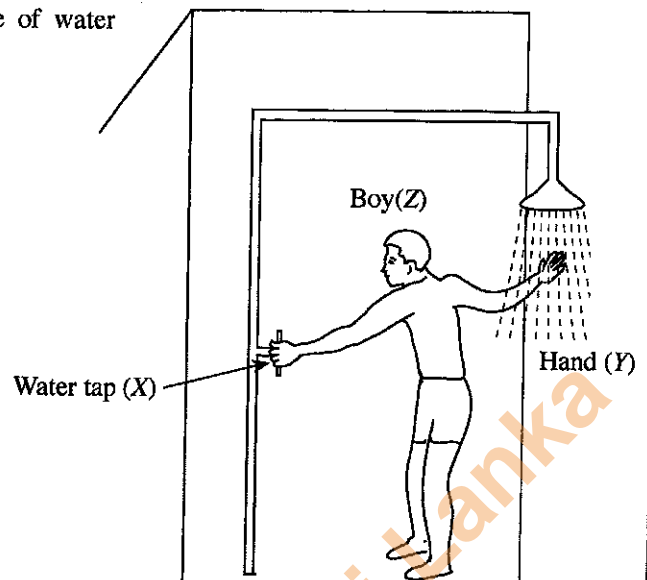

Which choice best describes the above figure?

- (1) A closed loop system, X = output, Y = feedback/sensor, Z = controller
- (2) An open loop system, X = plant, Y = controller, Z = feedback/sensor
- (3) An open loop system, X = output, Y = feedback/sensor, Z = controller
- (4) A closed loop system, X = plant, Y = feedback/sensor, Z = controller
- (5) A closed loop system, X = input, Y = plant, Z = controller

36. Following block diagram shows a human operational liquid level control system of a tank.

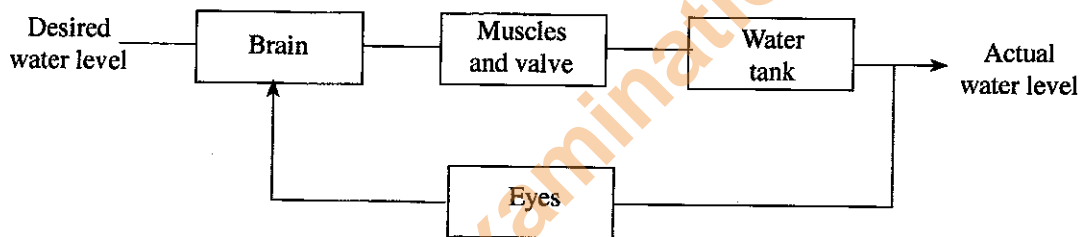

Which represents the controller, process/plant and feedback respectively?

- (1) Water tank, muscles and valve, eyes
- (2) Brain, eyes, muscles and valve
- (3) Muscles and valve, water tank, eyes
- (4) Muscles and valve, brain, water tank
- (5) Brain, muscles and valve, eyes

37. The diagram shows components of the refrigeration cycle.

When operating the refrigeration cycle, low pressure liquid exists between

- (1) P → Q
- (2) Q → R
- (3) R → S
- (4) S → P
- (5) P → R

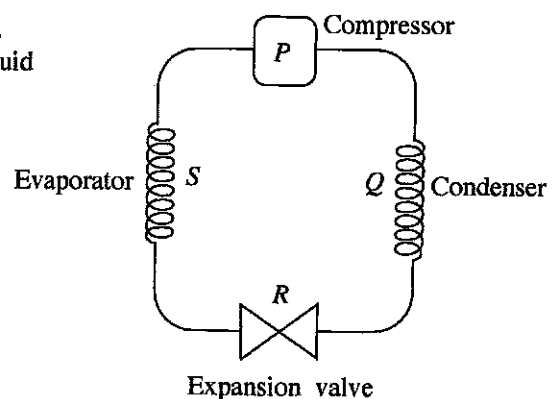

38. A student in the A/L technology class has made a screw thread around mild steel circular bar by using a die-nut and a handle. Then he checked the thread using a relevant nut. While he was inserting the nut and rotating it around the threaded bar, it goes down only two rounds and then fastened. Reason for this incident is

- (1) mismatch of pitch of threads around the bar and nut.
- (2) not using lubricant oil when rotating the nut around the threaded bar.
- (3) not using die-nut and die-handle correct way.
- (4) due to the burs that are still in the thread.
- (5) mismatch of materials of nut.

39. What is the most suitable method of joining 0.7 mm thick mild steel sheet and Aluminium sheet of the same thickness?

- (1) Riveting (2) Soft soldering (3) Metal inertgas welding
(4) Electric arc welding (5) Oxy-acetelene welding

40. Select the correct view of the object given below when looking from direction A.

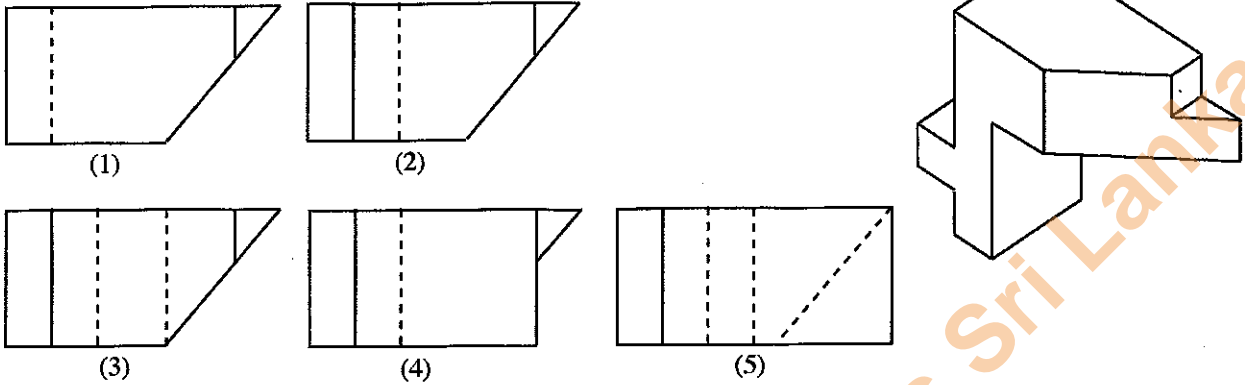

41. Following factors are to be considered when designing a machine for a textile factory.

- A - Location of control interfaces B - Operator's body dimensions
C - Operator's motion ranges D - Operator's age

Select the factors to be considered in the view point of ergonomics.

- (1) A, B and C only. (2) A, B and D only. (3) A, C and D only.
(4) B, C and D only. (5) A, B, C and D all.

42. Following statements describe a thermodynamic cycle.

- A - In a thermodynamic cycle properties depend only on the thermodynamic state.
B - Heat transfer and work done do not depend on the process.
C - Thermodynamic cycle is a series of thermodynamic processes.
D - Variables such as heat and work are not zero over a cycle.

Select the correct statements.

- (1) A, B and C only. (2) A, B and D only. (3) A, C and D only.
(4) B, C and D only. (5) A, B, C and D all.

43. Refrigeration is a process of moving heat from one location to another in controlled conditions. The formation of frost on cooling coils in a refrigerator is resulted

- A - Reduced power consumption B - Increased power consumption
C - Increased heat transfer D - Increased refrigerant wastage

Which of the above statements are **incorrect**?

- (1) A, B and C only. (2) A, B and D only. (3) A, C and D only.
(4) B, C and D only. (5) A, B, C and D all.

44. A car stopped screeching to avoid crash with a van. What change of energy is involved in that process?

- (1) Kinetic energy is converted into sound energy
(2) Kinetic energy is converted into sound and thermal energy
(3) Potential energy is converted into sound, heat and kinetic energy
(4) Kinetic and potential energy is converted into thermal and sound energy
(5) Potential energy is converted into sound energy

45. Tool life can be defined as the length of cutting time that a tool can be used until catastrophic failure.

- A - Quick dulling by plastic deformation.
B - Mechanical breakage of cutting tool due to excessive forces and shocks.
C - Gradual wear of the cutting tool.
D - Quick dulling by elastic deformation.

Which of the above statements give the failure modes of cutting tools?

- (1) A, B and C only. (2) A, B and D only. (3) A, C and D only.
(4) B, C and D only. (5) A, B, C and D all.

46. Figure shows a mechanism used to lift a load. The load can be lifted up or moved down by rotating the handle. r_1 and r_2 are radii of pulleys. Consider the four statements given below.

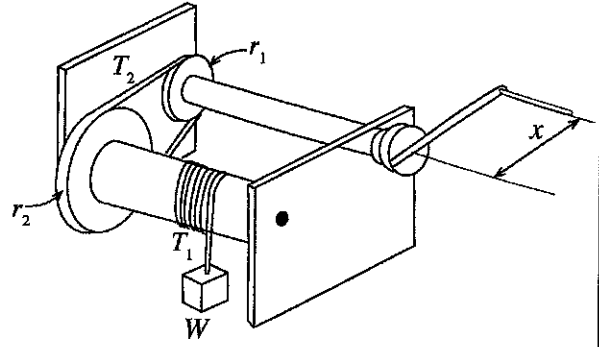

- A - Tension (T_1) of the cable depends on the load (W)
 B - Belt drive is not suitable for this kind of mechanism since slipping can occur.
 C - In order to reduce the effort of lifting, x should be increased and r_2 should be decreased.
 D - In order to reduce the effort $\frac{r_2}{r_1} > 1$

What are the correct statements?

- (1) A, B and C only. (2) A, B and D only. (3) A, C and D only.
 (4) B, C and D only. (5) A, B, C and D all.
47. Schematic diagram of a domestic water supply system is shown in the figure. Water flow rate and water pressure of the relevant places are given from Q_1 to Q_5 and P_1 to P_5 respectively. Assuming that the water flow is incompressible consider the following statements.

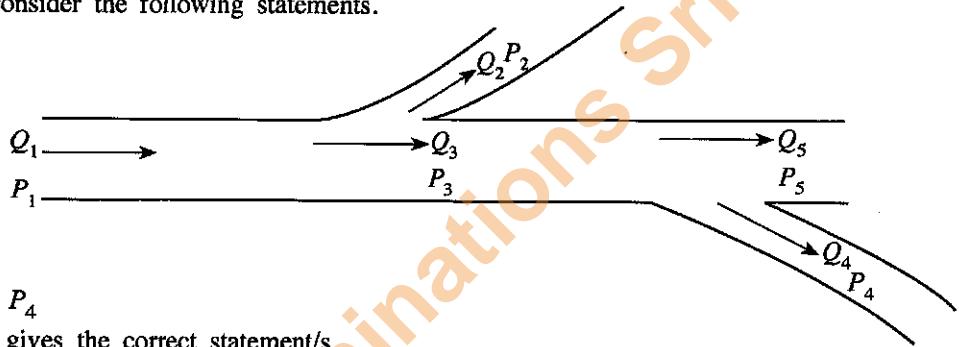

- A - $Q_1 = Q_2 + Q_3$
 B - $Q_5 = Q_3 - Q_4$
 C - $P_3 > P_5$ and $P_3 < P_4$

Select the choice which gives the correct statement/s.

- (1) A only. (2) A and B only. (3) B and C only.
 (4) C and D only. (5) A, B and C all.
48. Select the correct choice which is relevant to third angle projection of Engineering drawings.
- (1) The view obtained when looking from front is drawn behind the object.
 (2) The view obtained when looking from left direction is drawn in right side.
 (3) Plan is drawn at the bottom.
 (4) Right side view is drawn in left side.
 (5) Plan is drawn at the top.
49. What are the correct statements regarding Ergonomics and Anthropometry?
- A - Ergonomics is the science involved with the comprehension of interactions among humans and other systems.
 B - Ergonomics can not be used to increase the productivity.
 C - Anthropometry plays a significant role in Ergonomic design and industrial design.
 D - Anthropometry involves the systematic measurement of physical properties of the human body.
- (1) A, B and C only. (2) A, B and D only. (3) A, C and D only.
 (4) B, C and D only. (5) A, B, C and D all.

50. The value of normal reaction (R) for the following object on a surface is given by where, W = weight of block, P = Applied force, μ = Coefficient of friction, θ = Angle.

- (1) $W - P \sin\theta$
 (2) $W + P \sin\theta$
 (3) $P - W \sin\theta$
 (4) $P + W \sin\theta$
 (5) $P - P \cos\theta$

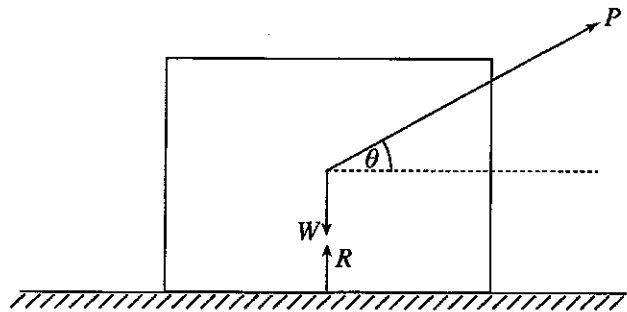

Department of Examinations Sri Lanka

Department of Examinations Sri Lanka

සියලු ම හිමිකම් ඇවිරිණි / முழுப் பதிப்புரிமையுடையது / All Rights Reserved

ශ්‍රී ලංකා විභාග දෙපාර්තමේන්තුව ශ්‍රී ලංකා විභාග දෙපාර්තමේන්තුව ශ්‍රී ලංකා විභාග දෙපාර්තමේන්තුව ශ්‍රී ලංකා විභාග දෙපාර්තමේන්තුව ශ්‍රී ලංකා විභාග දෙපාර්තමේන්තුව
 இலங்கைப் பரீட்சைத் திணைக்களம் இலங்கைப் பரීட்சைத் திணைக்களம் இலங்கைப் பரීட்சைத் திணைக்களம் இலங்கைப் பரීட்சைத் திணைக்களம் இலங்கைப் பரීட்சைத் திணைக்களம்
 Department of Examinations, Sri Lanka Department of Examinations, Sri Lanka Department of Examinations, Sri Lanka Department of Examinations, Sri Lanka Department of Examinations, Sri Lanka
 ශ්‍රී ලංකා විභාග දෙපාර්තමේන්තුව ශ්‍රී ලංකා විභාග දෙපාර්තමේන්තුව ශ්‍රී ලංකා විභාග දෙපාර්තමේන්තුව ශ්‍රී ලංකා විභාග දෙපාර්තමේන්තුව ශ්‍රී ලංකා විභාග දෙපාර්තමේන්තුව
 இலங்கைப் பரීட்சைத் திணைக்களம் இலங்கைப் பரීட்சைத் திணைக்களம் இலங்கைப் பரීட்சைத் திணைக்களம் இலங்கைப் பரීட்சைத் திணைக்களம் இலங்கைப் பரීட்சைத் திணைக்களம்
 Department of Examinations, Sri Lanka Department of Examinations, Sri Lanka Department of Examinations, Sri Lanka Department of Examinations, Sri Lanka Department of Examinations, Sri Lanka

අධ්‍යයන පොදු සහතික පත්‍ර (උසස් පෙළ) විභාගය, 2016 අගෝස්තු
 கல்விப் பொதுத் தராதரப் பத்திர (உயர் தர)ப் பரீட்சை, 2016 ஓகஸ்ட்
 General Certificate of Education (Adv. Level) Examination, August 2016

යාන්ත්‍රික තාක්ෂණවේදය II
 பொறிமுறைத் தொழினுட்பவியல் II
 Mechanical Technology II

15 E II

පැය තුනයි
 மூன்று மணித்தியாலம்
 Three hours

Index No. :

Important :

- * This question paper consists of 12 pages.
- * This question paper comprises **Parts A, B and C**. The time allotted for all parts is three hours.
(Use of calculators is **not** allowed.)

Part A - Structured Essay (08 pages)

- * Answer **all** the questions on this paper itself.
- * Write your answers in the space provided for each question. Note that the space provided is sufficient for your answers and that extensive answers are not expected.

Part B and C - Essay (04 pages)

- * Select minimum of **two** questions from each of the parts **B and C** and answer **four** questions only. Use the papers supplied for this purpose. At the end of the time allotted for this paper, tie the **three parts** together so that **Part A** is on the top of **Part B and C** before handing over to the supervisor.
- * You are permitted to remove only **Parts B and C** of the question paper from the Examination Hall.

For Examiner's Use Only

| Part | Q. No. | Marks |
|-------------------|--------|-------|
| A | 1 | |
| | 2 | |
| | 3 | |
| | 4 | |
| B | 1 | |
| | 2 | |
| | 3 | |
| C | 4 | |
| | 5 | |
| | 6 | |
| Total | | |
| Percentage | | |

Final Marks

| | |
|------------|--|
| In Numbers | |
| In Words | |

Code Numbers

| | |
|--------------------|--|
| Marking Examiner 1 | |
| Marking Examiner 2 | |
| Checked by | |
| Supervised by | |

Do not write in this column

PART A – Structured Essay
 Answer *all four* questions on this *paper itself*.

1. An isometric view of a machine component is shown in Figure 1. Machine component is symmetric along the vertical plane passing through X-X. Two holes of diameter 10 mm ($\Phi 10$) passes completely through the component. Assuming any missing dimensions, draw the following views to a suitable scale using first angle projection principle. Show all relevant dimensions in the sketches. Use the graph sheets given on page 3 and 4 to answer the questions. (All dimension are in mm.)

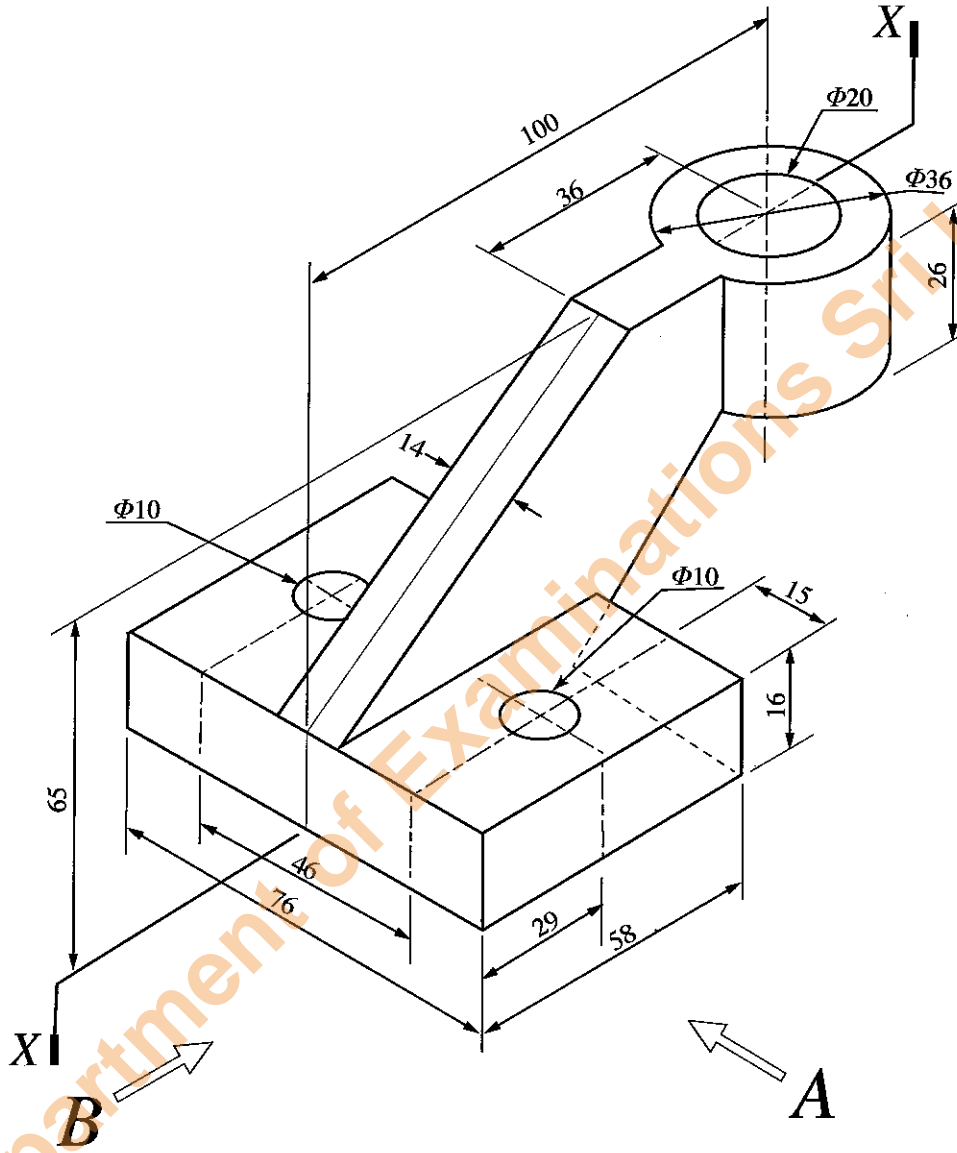

- (ii) Front elevation seen through direction A.
- (ii) End elevation seen through direction B.
- (iii) Plan.



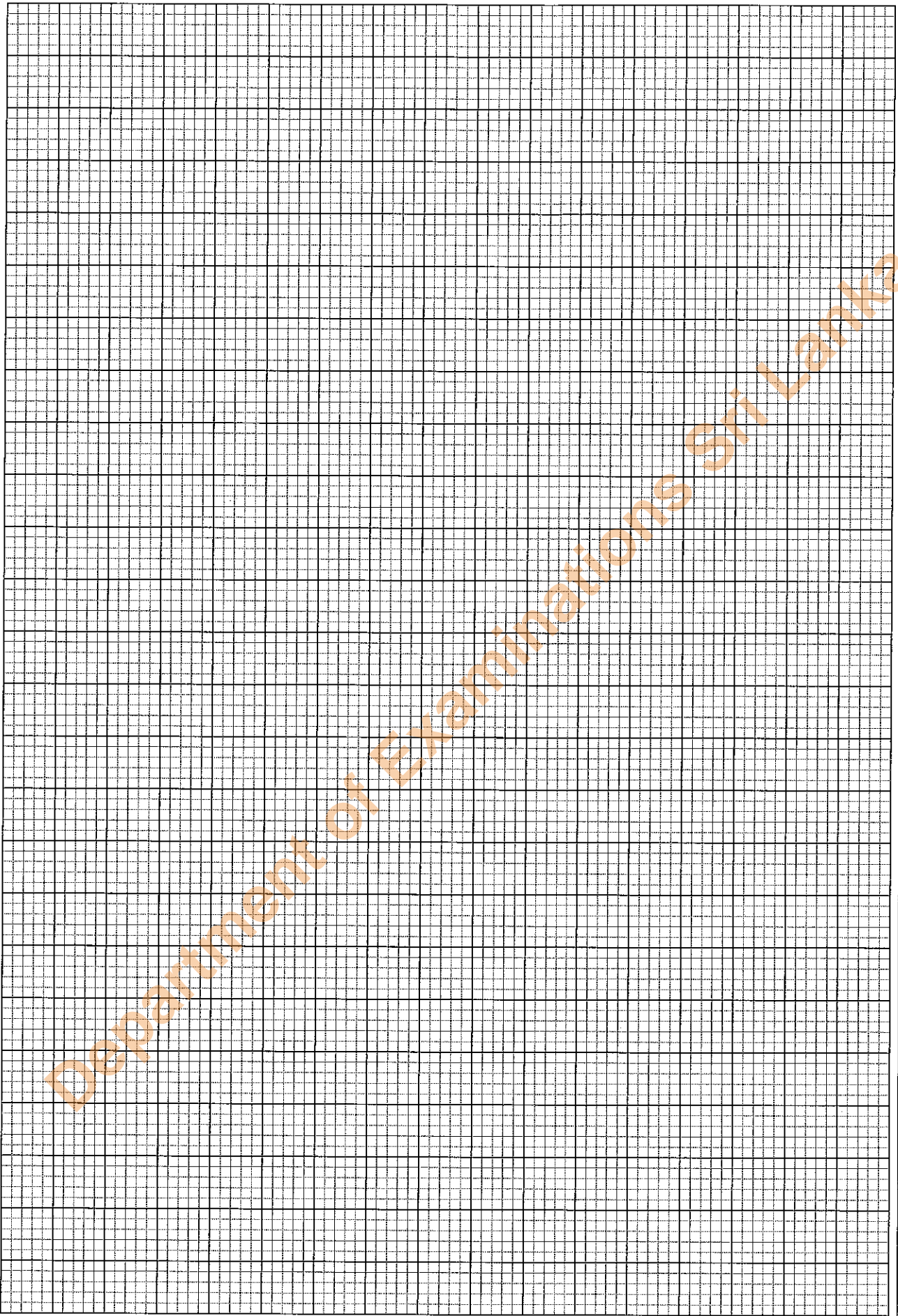

Department of Examinations Sri Lanka

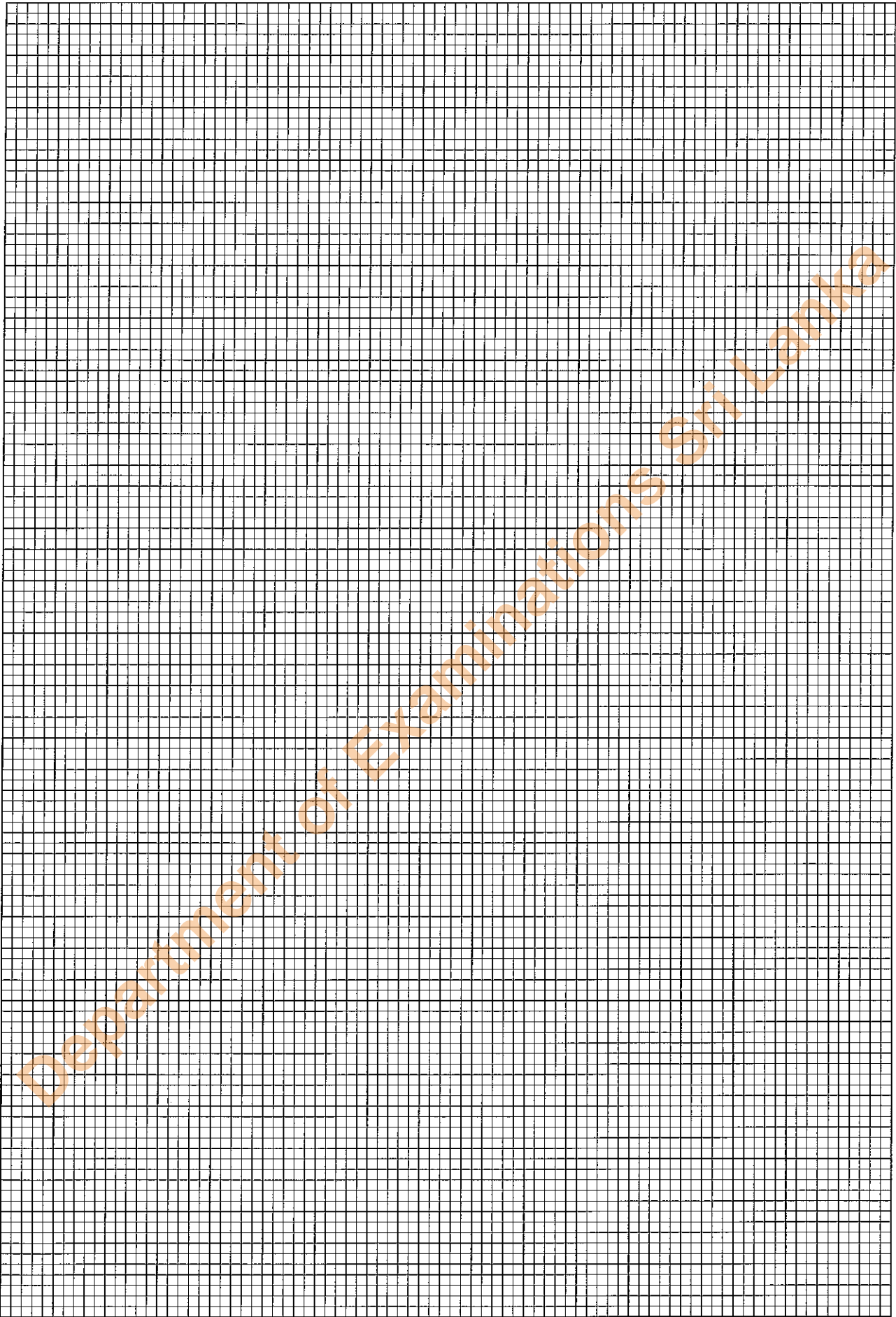

Do not write in this column

2. ABC school has a computer laboratory and a conference room. As the IT technician, you are assigned with the task to upgrade the IT facilities of the ABC school. The computer laboratory has 20 working desktop computers. It is decided to add another 30 computers to the laboratory.

(a) 10 computers will be assembled by using the components in good working conditions from computers removed from the laboratory due to various faults. Consider that the following list of components are in good working condition.

- Mother board 15 units
- Casing of the system unit with power supply and other accessories 20 units
- RAM card 10 units
- Hard disk 15 units
- LCD monitor 15 units
- Mouse 15 units
- Keyboard 20 units
- DVD player and writer 10 units

Note: Assume that all hardware items are compatible and large stock of cables and connectors are available.

(i) Select **four** items required to assemble a basic system unit from the available list.

- (1)
- (2)
- (3)
- (4)

(ii) List another **three** hardware items required to prepare a fully functional computer in addition to the system units.

- (1)
- (2)
- (3)

(iii) Assume that these ten computer units will be used to prepare documents, presentations, create drawings and to edit pictures. List **four** softwares required to make these ten computers fully functional.

- (1)
- (2)
- (3)
- (4)

(b) Assume that ten computers have been assembled and another twenty computers have been bought. Currently computers are not connected to a computer network and no internet facilities are available.

(i) List **three** hardware items required to create a computer network of fifty computers.

- (1)
- (2)
- (3)

Department of Examinations Sri Lanka

Do not write in this column

(ii) Propose a method to supply the internet facilities for the computer laboratory.

.....

.....

.....

.....

.....

(c) The conference room will be renovated with multimedia facilities, facilities for video conferencing, for conducting workshops and seminars by resource persons from distance places using online facilities.

(i) List **three** input/output hardware devices required for the computer in addition to the basic input/output devices.

(1)

(2)

(3)

(ii) Mention **one** specific software required for the conference room in addition to the basic application software.

.....

.....



3. Figure shows segment of a cone which cuts parallel to its base. All dimensions are in cm.

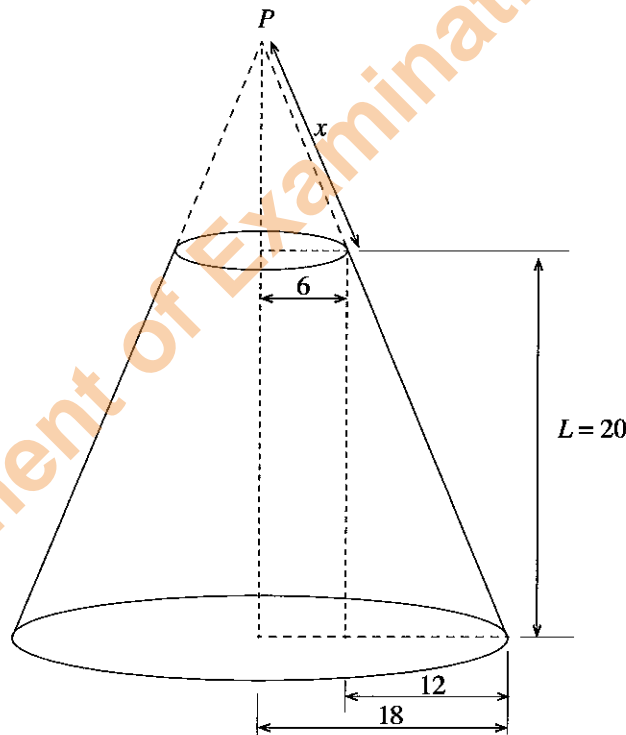

(a) If vertex of the cone is P, calculate the inclined height(x) from P to cutting plane.

.....

.....

.....

.....

.....

.....

Do not
write
in this
column

(b) Draw development of segment of the cone.

4. When a vehicle is running at constant speed of 40 ms^{-1} , the driver sees a passenger crossing the road at 100 m away. The driver applies breaks to avoid collision and the velocity of the vehicle changes according to the Figure.

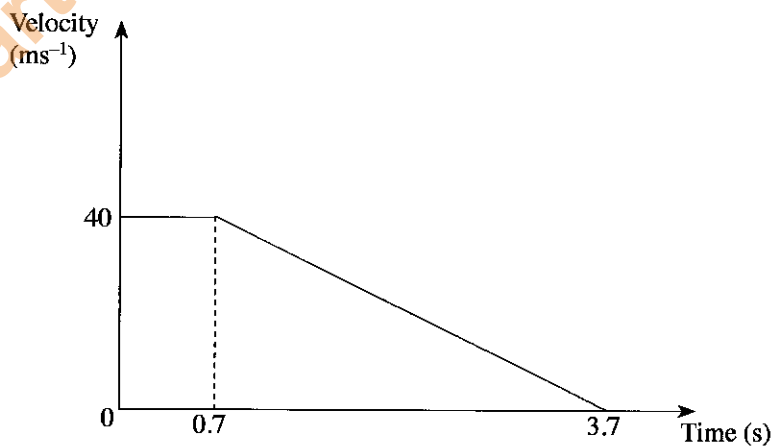
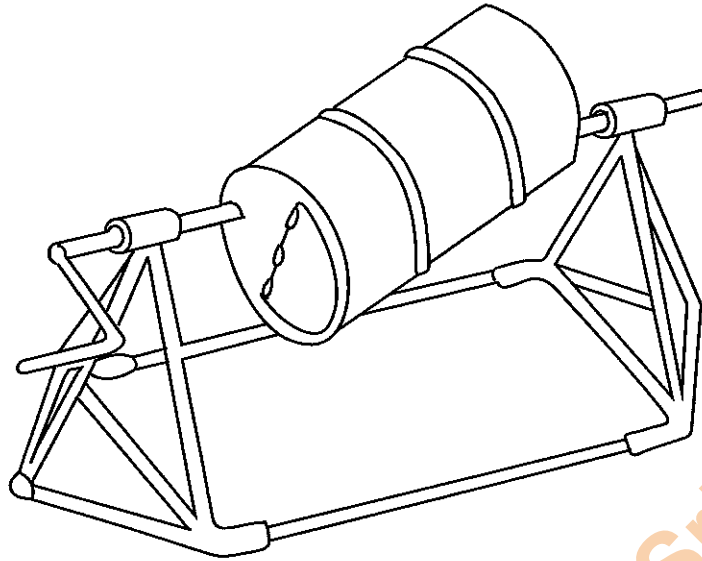

Figure Q3

[see page eight]

2. Figure shows a sketch of a home-built concrete mixer made of items that can be purchased from a general hardware store.



Suppose that your team is given the task to design and built the said device for your school building project.

- Sketch the sectional view of the rotating parts to an approximate scale, on a vertical plane passing through its rotating axis. Show details of connection between the drum and its axle, and steps taken to reduce energy loss due to friction.
 - Estimate the volume of concrete you could mix in a single batch. Explain how you have arrived at the estimated value. State any assumptions you have made in this regard.
 - Estimate the amount of torque that one has to give in order to rotate the drum, when it is mixing the quantity of concrete estimated in (b) above. Explain how you have arrived at the estimated value. State any assumptions you have made in this regard.
3. Congenital disorders, diseases, injuries and accidents have caused a considerable number of differently-abled persons living with amputated limbs, weak limbs and loss of vision, hearing or speech. Societies have now accepted the need to make their life comfortable and to facilitate them to contribute to society, to the best of their abilities. In this regard, technological innovations are playing a greater role. Select one type of disability of your choice.
- Discuss how modern technological innovations have made such individuals to be productive individuals.
 - Explain how the innovations discussed in 3(a) above, facilitates such individuals to live with their family and loved ones comfortably, rather than living in a facility dedicated to such individuals.
 - Describe instances where such individuals can contribute to their household and/or society while being differently-abled.

Part C

4. Green houses are used to maintain artificially the environment conditions for growing crops. Following figure shows a schematic diagram of a green house.

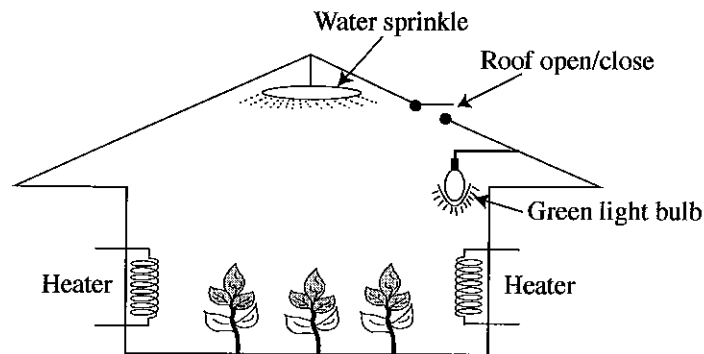

- (a) List down **three** parameters that need to be sensed in order to grow plants.
- (b) What are the sensors that can measure these parameters?
- (c) The green house is operated as a closed loop feedback control system. The sensors mentioned in (b) above are used to provide feedbacks. Using appropriate block diagrams briefly explain how you control,
- heater.
 - green light in the system.
5. Canned fruits and vegetables are picked and packed at the peak of ripeness, guaranteeing superior food freshness. Once the cans are sealed and heat-processed, the food maintains its high quality and freshness. Although most cans are cylindrical in shape, cans may be manufactured in other shapes, including rectangular cans and oblong cans. In addition, food grade metal coatings are the ideal products for broad range of uses in the food industry. Figure shows a cylindrical-shaped drinking can.
- (a) State the **three** factors that need to be considered when manufacturing a food can.
- (b) Give **two** materials used for drinking cans?
- (c) Briefly describe **two** factors that should be considered when selecting the can material.
- (d) State the possible manufacturing process of the can shown in Figure 2.

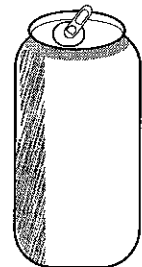

6. A chair is to be designed for seated workers of a textile factory taking ergonomic aspects into consideration. A seated worker normally works five days per week and an eight hour shift per day.

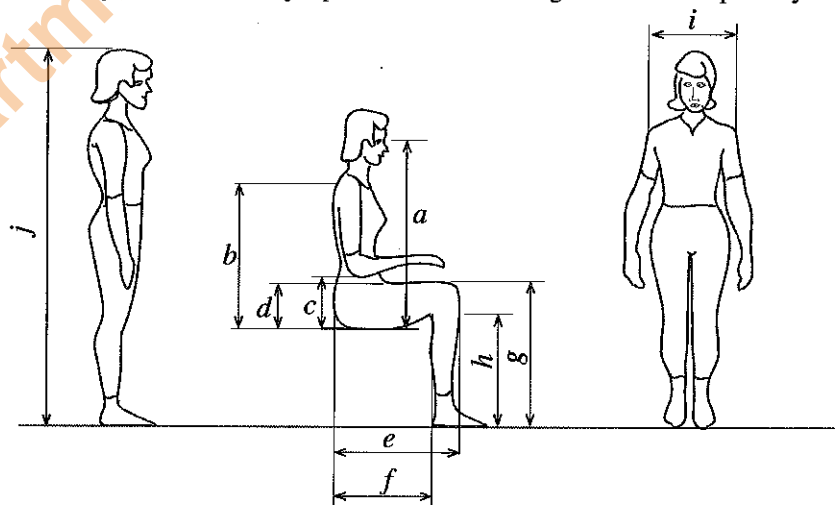

Figure 6

- (a) Illustrate using a sketch the key dimension of the chair that is designed considering ergonomic aspects.

- An anthropometric study has been conducted and the results have been obtained for a specific community as shown in Table 1 and Figure 1. All dimensions are in mm.

| | Dimension | Men | | | | Women | | | |
|---|--------------------------|----------------|-----------------|-----------------|--------------------|----------------|-----------------|-----------------|--------------------|
| | | 5th Percentile | 50th Percentile | 95th Percentile | Standard Deviation | 5th Percentile | 50th Percentile | 95th Percentile | Standard Deviation |
| a | Sitting eye height | 735 | 790 | 845 | 35 | 685 | 740 | 795 | 33 |
| b | Sitting shoulder height | 540 | 595 | 645 | 32 | 505 | 555 | 610 | 31 |
| c | Sitting elbow height | 195 | 245 | 295 | 31 | 185 | 235 | 280 | 29 |
| d | Thigh clearance | 135 | 160 | 185 | 15 | 125 | 155 | 180 | 17 |
| e | Buttock-knee length | 540 | 595 | 645 | 31 | 520 | 570 | 620 | 30 |
| f | Buttock-popliteal length | 440 | 495 | 550 | 32 | 435 | 480 | 530 | 30 |
| g | Knee height | 490 | 545 | 595 | 32 | 455 | 500 | 540 | 27 |
| h | Popliteal height | 395 | 440 | 490 | 29 | 355 | 400 | 445 | 27 |
| i | Shoulder breadth | 420 | 465 | 510 | 28 | 355 | 395 | 435 | 24 |
| j | Stature | 1625 | 1740 | 1855 | 70 | 1505 | 1610 | 1710 | 62 |

Table 1

- (b) Using above figure and table determine the dimension of a chair for seated work for a 95th percentile woman of this community.
- (c) What are the implications if this chair is used by 95th percentile woman in other communities.

* * *