

ශ්‍රී ලංකා විභාග දෙපාර්තමේන්තුව ශ්‍රී ලංකා විභාග දෙපාර්තමේන්තුව ශ්‍රී ලංකා විභාග දෙපාර්තමේන්තුව ශ්‍රී ලංකා විභාග දෙපාර්තමේන්තුව ශ්‍රී ලංකා විභාග දෙපාර්තමේන්තුව
 இலங்கைப் பரீட்சைத் திணைக்களம் இலங்கைப் பரීட்சைத் திணைக்களம் இலங்கைப் பரීட்சைத் திணைக்களம் இலங்கைப் பரීட்சைத் திணைக்களம் இலங்கைப் பரීட்சைத் திணைக்களம்
 Department of Examinations, Sri Lanka Department of Examinations, Sri Lanka Department of Examinations, Sri Lanka Department of Examinations, Sri Lanka Department of Examinations, Sri Lanka
 இலங்கைப் பரීட்சைத் திணைக்களம் இலங்கைப் பரීட்சைத் திணைக்களம் இலங்கைப் பரīட்சைத் திணைக்களம் இலங்கைப் பரīட்சைத் திணைக்களம் இலங்கைப் பரīட்சைத் திணைக்களம்
 Department of Examinations, Sri Lanka Department of Examinations, Sri Lanka Department of Examinations, Sri Lanka Department of Examinations, Sri Lanka Department of Examinations, Sri Lanka

අධ්‍යයන පොදු සහතික පත්‍ර (උසස් පෙළ) විභාගය, 2016 අගෝස්තු
 கல்விப் பொதுத் தராதரப் பத்திர (உயர் தர)ப் பரீட்சை, 2016 ஆகஸ்ட்
 General Certificate of Education (Adv. Level) Examination, August 2016

කාක්ෂණවේදය සඳහා විද්‍යාව I
 தொழினுட்பவியலுக்கான விஞ்ஞானம் I
 Science for Technology I

67 E I

පැය දෙකයි
 இரண்டு மணித்தியாலம்
 Two hours

Instructions:

- * Answer all the questions.
- * Write your **Index Number** in the space provided in the answer sheet.
- * Read the instructions given on the back of the answer sheet carefully.
- * In each of the questions 1 to 50, pick one of the alternatives from (1), (2), (3), (4), (5) which is **correct or most appropriate** and mark your response on the answer sheet with a cross (×) in accordance with the instructions given on the back of the answer sheet.
- * Use of calculators is not allowed.

1. One of the main features of bacteria is
 - (1) presence of chitin in cell wall.
 - (2) absence of nuclear membrane.
 - (3) presence of 80S ribosomes.
 - (4) being essential parasites.
 - (5) multiply only in living cells.
2. Vinegar production is done by using only,
 - (1) yeast.
 - (2) acetic acid bacteria.
 - (3) yeast with lactic acid bacteria.
 - (4) yeast with acetic acid bacteria.
 - (5) yeast with butyric acid bacteria.
3. Functional groups available in biomolecules denoted as A and B are shown in the table given below.

Biomolecule	Functional group/s
A	Only -COOH group
B	Only -COOH and -NH ₂ groups

Which of the following biomolecules represent A and B in order?

- (1) Amino acid and fatty acid
 - (2) Amino acid and glucose
 - (3) Fatty acid and glucose
 - (4) Fatty acid and amino acid
 - (5) Glucose and amino acid
4. Consider the following statements about enzymes.
 - (A) Activity of an enzyme is independent on the pH value of the medium.
 - (B) Activity of an enzyme depends on its specific three dimensional shape.
 - (C) Most enzymes are active between 5 °C to 40 °C range of temperature.
 Of the above, the correct statement/s would be
 - (1) (A) only.
 - (2) (B) only.
 - (3) (C) only.
 - (4) (A) and (B) only.
 - (5) (B) and (C) only.
 5. Which compound can be used as a raw material for the production of biodiesel?
 - (1) Glycerol
 - (2) Triglyceride
 - (3) Cellulose
 - (4) Protein
 - (5) Starch
 6. In paint manufacturing process, titanium dioxide (TiO₂) is mainly used as
 - (1) a solvent.
 - (2) an additive.
 - (3) a binder.
 - (4) a pigment.
 - (5) a filler.
 7. Consider the following statements about thermoplastics.
 - (A) They consist of cross links.
 - (B) They can be softened on heating.
 - (C) They can only be moulded once.
 Of the above, the correct statement/s would be
 - (1) (A) only.
 - (2) (B) only.
 - (3) (C) only.
 - (4) (A) and (B) only.
 - (5) (B) and (C) only.

8. Recrystallization technique can be used to
- (1) filter a solution.
 - (2) obtain a solid product from vapour.
 - (3) identify the presence of impurities in a product.
 - (4) dissolve a solid product in a solvent.
 - (5) purify a raw product.
9. Consider the following statements regarding secondary metabolites.
- (A) All secondary metabolites can be used as medicinal drugs.
 - (B) All secondary metabolites can be extracted easily.
 - (C) Usually secondary metabolites are naturally produced in small quantities.

Of the above, the correct statement/s would be

- (1) (A) only.
 - (2) (B) only.
 - (3) (C) only.
 - (4) (A) and (C) only.
 - (5) (B) and (C) only.
10. What is the **false** statement regarding a patent?
- (1) It protects the rights of an inventor.
 - (2) It is issued by the government.
 - (3) It can be used to introduce an invention to the society.
 - (4) An applicant must be an owner of an industry.
 - (5) It can be obtained for a novel process.
11. Which of the following statements is true regarding photochemical smog?
- (1) It does not produce adverse effects on humans.
 - (2) Hydrocarbon is not required for its development.
 - (3) Sunlight is not required for its development.
 - (4) Sulphur dioxide is required for its development.
 - (5) It consists of various gases.
12. Which of the following processes produce nitrogen gas?
- (1) Denitrification
 - (2) Industrial nitrogen fixation
 - (3) Photosynthesis
 - (4) Respiration
 - (5) Lightning
13. An inflated balloon with air is expanded due to heat of sunlight. If the heat absorbed into the balloon is 450 J and the work done by the balloon is 127 J, what is the internal energy difference of the balloon?
- (1) -450 J
 - (2) + 127 J
 - (3) + 323 J
 - (4) + 450 J
 - (5) + 577 J
14. Which statement is correct regarding thermodynamic systems and processes?
- (1) All known processes are exothermic.
 - (2) Boundary of a system must be visible to the naked eye.
 - (3) All real systems are closed systems.
 - (4) Total energy of an isolated system can be changed.
 - (5) A temperature difference can produce a heat flow.
15. Consider the following statements regarding catalysts.
- (A) They always exist in solid state when they are active.
 - (B) They increase reaction rate.
 - (C) They are altered chemically at the end of the reaction.
 - (D) They increase the activation energy of reactions.

Of the above, the correct statement/s would be

- (1) (A) only.
 - (2) (B) only.
 - (3) (B) and (C) only.
 - (4) (B) and (D) only.
 - (5) (A), (B) and (C) only.
16. Decomposition of $\text{NO}_2(\text{g})$ can be shown as follows.
- $$2\text{NO}_2(\text{g}) \longrightarrow 2\text{NO}(\text{g}) + \text{O}_2(\text{g})$$
- Which is true regarding the above reaction?
- (1) Production rate of $\text{NO}(\text{g}) = -\frac{\Delta C_{(\text{NO})}}{\Delta t}$
 - (2) Production rate of $\text{NO}(\text{g}) = \frac{\Delta C_{(\text{NO})}}{\Delta t}$
 - (3) Reaction rate decreases with the temperature increase.
 - (4) Concentration of $\text{NO}_2(\text{g})$ has no effect on the reaction rate.
 - (5) When the pressure of $\text{NO}_2(\text{g})$ decreases, the reaction rate increases.

17. Which is true about nano-particles?

- (1) Their diameter is in the scale of millimetres.
- (2) They have a large $\frac{\text{surface area}}{\text{weight}}$ ratio.
- (3) They always show only their elemental properties.
- (4) They only originate naturally.
- (5) A particle has only one element.

18. A home garden is to be constructed using the shape and measurements given in the figure. What is the area of the garden?

- (1) 50 m^2
- (2) 100 m^2
- (3) 150 m^2
- (4) 200 m^2
- (5) 250 m^2

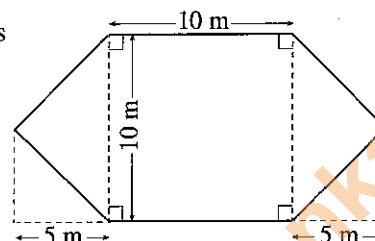

19. A cylindrical container with the radius of 14 cm and the height of 20 cm is to be constructed using a metal plate to pack milk powder. What is the minimum area of the metal plate, including the base and the lid, required to construct the container? (Consider $\pi = \frac{22}{7}$)

- (1) 1760 cm^2
- (2) 2376 cm^2
- (3) 2992 cm^2
- (4) 4984 cm^2
- (5) 13220 cm^2

20. A plastic solid model with the shape of an ice cream cone having measurements as shown in the figure is to be constructed to promote ice-cream sales. This model is to be constructed by combining two conical solid objects together. What is the minimum volume of the plastic required to construct this model?

(Consider $\pi = \frac{22}{7}$)

- (1) 2200 cm^2
- (2) 2200 cm^3
- (3) 46200 cm^2
- (4) 46200 cm^3
- (5) 138600 cm^3

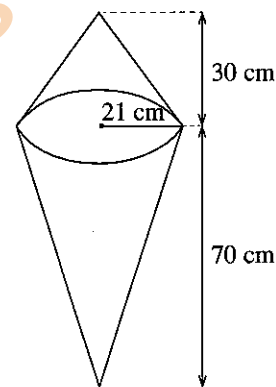

21. If the lamp post AB shown in the given figure is vertical, what should be the height of AB , assuming that all the measurements were taken from a point C on the horizontal ground?

- (1) $\sqrt{21} \text{ m}$
- (2) $\sqrt{29} \text{ m}$
- (3) 7 m
- (4) 21 m
- (5) 29 m

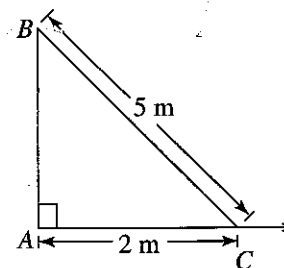

22. What is the area of the triangle ABC if $AB = 8 \text{ cm}$, $AC = 6 \text{ cm}$, and $\hat{A} = 30^\circ$?

(Consider that $\sin 30^\circ = \frac{1}{2}$, $\cos 30^\circ = \frac{\sqrt{3}}{2}$ and $\tan 30^\circ = \frac{1}{\sqrt{3}}$.)

- (1) $\frac{12}{\sqrt{3}} \text{ cm}^2$
- (2) $\frac{12}{\sqrt{2}} \text{ cm}^2$
- (3) 12 cm^2
- (4) $12\sqrt{3} \text{ cm}^2$
- (5) 24 cm^2

23. As shown in the diagram, shaded area with the centre O and radius 28 cm has been removed from a circular metal plate. The area of the piece of metal plate removed in terms of π is

- (1) $49\pi \text{ cm}^2$
- (2) $98\pi \text{ cm}^2$
- (3) $196\pi \text{ cm}^2$
- (4) $392\pi \text{ cm}^2$
- (5) $784\pi \text{ cm}^2$

24. What is the shortest distance between the points $A = (5, 6)$ and $B = (7, 12)$ on a Cartesian plane?

- (1) $\sqrt{8}$
- (2) $\sqrt{26}$
- (3) $\sqrt{40}$
- (4) 26
- (5) 40

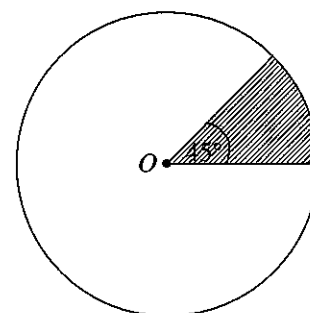

25. If the two straight lines of equations $y = 2x + 3$ and $2y = mx + 4$ are perpendicular to each other, what is the value of m ?

(1) -1 (2) $-\frac{1}{2}$ (3) 1 (4) 2 (5) 4

26. Consider the given ungrouped frequency distribution.

What is the mean of the distribution?

(1) 4.00 (2) 4.42 (3) 4.50
(4) 5.89 (5) 6.00

Value	Frequency
3	4
4	9
5	8
6	3

27. The speeds of 18 motor vehicles passing at a particular point on a road are summarized as shown in the table.

What are the lower boundary and the less than cumulative frequency of the class 30 – 39 respectively?

(1) 29.5, 8 (2) 29.5, 11
(3) 29.5, 15 (4) 30, 8 (5) 30, 11

Speed interval / km h ⁻¹	Frequency
20 – 29	3
30 – 39	8
40 – 49	5
50 – 59	2

28. Internet Explorer is a/an

(1) operating system. (2) spreadsheet software.
(3) web browser. (4) web search engine.
(5) word processing software.

29. Consider the following storage/memory devices used in computers.

(A) RAM (B) ROM (C) Hard disk

Which of the above is/are volatile storage/memory device(s)?

(1) (A) only (2) (B) only (3) (C) only
(4) (A) and (B) only (5) (B) and (C) only

30. Which of the following computer devices is only an input device?

(1) Hard disk (2) USB flash drive (3) Monitor
(4) Keyboard (5) Printer

31. Which of the following function, is **not** provided by a typical operating system of a computer?

(1) Managing users (2) Managing files
(3) Sharing CPU time among concurrent applications (4) Providing interfaces to users
(5) Protect the computer from viruses

32. In a typical word processing software, which key on the keyboard can be used to delete the character to the immediate left to the cursor?

(1) Delete (2) Space bar (3) Backspace (4) Tab (5) Enter

33. Consider the following statements about a typical word processing software.

(A) It is an application software.
(B) It is a tool for editing documents.
(C) It is a component of an operating system.

Which of the above statements is/are correct?

(1) (A) only (2) (B) only (3) (C) only
(4) (A) and (B) only (5) (B) and (C) only

34. The cell address A11 of a typical spread sheet contains the formula =SUM(A1:A10)/\$A\$15. If this formula is copied to the cell address B11, the formula contained at B11 cell would be,

(1) =SUM(A1:A10)/\$A\$15 (2) =SUM(A1:A10)/A15
(3) =SUM(B1:B10)/B15 (4) =SUM(B1:B10)/\$A\$15
(5) =SUM(B1:B10)/\$B\$15

35. Consider the following statements about the Internet and World Wide Web (WWW).

(A) A computer connected to the Internet can be identified uniquely by an e-mail address.
(B) A document in the WWW can be identified by using an IP address.
(C) The documents in WWW can be viewed by using a web browser.

Which of the above statements is/are correct?

(1) (A) only (2) (B) only (3) (C) only
(4) (A) and (B) only (5) (B) and (C) only

36. Consider the following statements about the URL, <http://190.165.16.12/index.html>

- (A) 190.165.16.12 is an IP address of a computer in the Internet.
 (B) index.html is a name of a file.
 (C) http is the name of the web browser that should be used to view the resource given by the above URL.

Which of the above statements is/are true?

- (1) (A) only (2) (B) only (3) (C) only
 (4) (A) and (B) only (5) (B) and (C) only

37. Consider the following segment of a spreadsheet.

	A	B
1	25	
2	45	
3	12	
4	18	

Assume the formulae = A1 and = B1 + A2 are entered in the cell addresses B1 and B2, respectively. When the formula at the cell address B2 is copied to the cell B3, what would be the value displayed at cell B3?

- (1) 12 (2) 25 (3) 45 (4) 70 (5) 82

38. Which of the following is **not** a basic unit of the SI system?

- (1) m (2) kg (3) A (4) N (5) K

39. What is the most suitable instrument to measure the internal diameter of a capillary tube?

- (1) Meter ruler (2) Vernier calliper
 (3) Sliding calliper (4) Travelling microscope
 (5) Micrometer screw gauge

40. Which of the following measurements **cannot** be taken by using any of the measuring instruments; meter ruler, travelling microscope, vernier calliper and micrometer screw gauge?

- (1) 0.037 cm (2) 2.018 cm (3) 10.132 cm (4) 46.39 cm (5) 72.1 cm

41. Kilowatt hour (kW h) is being used to measure

- (1) power. (2) energy. (3) current. (4) voltage. (5) time.

42. An equal amount of heat is supplied separately to two liquids A and B of mass m and $2m$, respectively. The specific heat capacity of liquid A is half that of liquid B. If the increase in temperature of liquids A and B are θ_A , θ_B respectively which of the following relationships is true?

- (1) $\theta_A = \frac{\theta_B}{4}$ (2) $\theta_A = \frac{\theta_B}{2}$ (3) $\theta_A = \theta_B$ (4) $\theta_A = 2\theta_B$ (5) $\theta_A = 4\theta_B$

43. Two forces with magnitudes of 3 N and 4 N are acting on an object perpendicular to each other as shown in the figure.

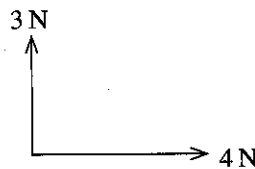

Which of the following figures represents the resultant force?

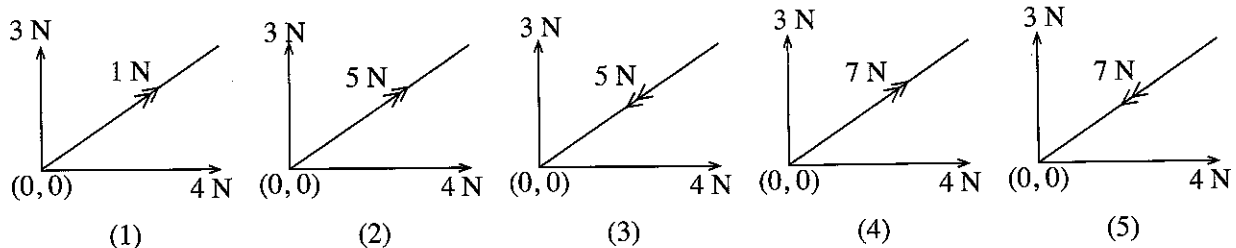

44. A uniform solid cylinder with mass of 6 kg floats vertically in a liquid such that $\frac{1}{3}$ of its height is above the surface of the liquid as shown in the figure. The required minimum vertical force (P) to submerge the cylinder completely in the liquid is

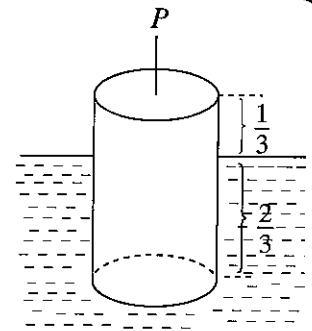

- (1) 15 N
 (2) 20 N
 (3) 30 N
 (4) 40 N
 (5) 120 N

45. A motor vehicle with a total mass of 800 kg mass has brake pads of total mass 4.8 kg. The specific heat capacity of the material of brake pads is $1200 \text{ J kg}^{-1} \text{ K}^{-1}$. The motor vehicle travelling at 15 m s^{-1} speed stopped by applying brakes. If the loss of kinetic energy of the motor vehicle is assumed to be transferred completely to the heat of brake pads, the quantity of temperature increase of the brake pads is

- (1) $\frac{2 \times 800 \times 15^2}{4.8 \times 1200} \text{ K}$.
 (2) $\frac{2 \times 4.8 \times 1200}{800 \times 15^2} \text{ K}$.
 (3) $\frac{800 \times 4.8 \times 1200}{2 \times 15^2} \text{ K}$.
 (4) $\frac{800 \times 15^2}{2 \times 4.8 \times 1200} \text{ K}$.
 (5) $\frac{2 \times 15^2}{800 \times 4.8 \times 1200} \text{ K}$.

46. Two equal resistors connected in series to a battery with negligible internal resistance dissipate power of 12 W. If these two resistors are connected in parallel across the same battery, the complete power dissipation is

- (1) 6 W. (2) 12 W. (3) 24 W. (4) 36 W. (5) 48 W.

47. One end of a wire with initial length l and a cross sectional area A is fixed to a ceiling as shown in the figure and an object of a weight W is tied to the other end of the wire. It was found that, when the weight of the object is reduced by half, the extension of the wire is reduced by $\frac{l}{8}$. The Young's modulus of the material of the wire is

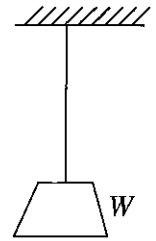

- (1) $\frac{Wl}{A^2}$. (2) $\frac{W}{2A}$. (3) $\frac{4W}{A}$.
 (4) $\frac{8Wl}{A^2}$. (5) $\frac{9W}{10A}$.

48. The variation of electrical resistivity (ρ) with temperature (T) for three type of conductors are shown in the given three graphs (a), (b) and (c). The conductors corresponding to the graphs (a), (b) and (c) in order is

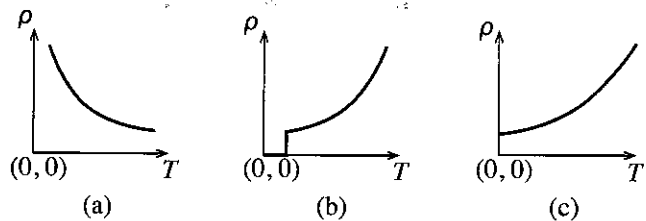

- (1) metallic conductor, semi-conductor and super conductor.
 (2) metallic conductor, super-conductor and semi-conductor.
 (3) super-conductor, metallic conductor and semi-conductor.
 (4) semi-conductor, super-conductor and metallic conductor.
 (5) semi-conductor, metallic conductor and super-conductor.

49. A mass tied to a light string is in a uniform circular motion around a fixed point on a smooth horizontal table. If the string is broken abruptly, the mass moves,

- (1) outward from the centre along the radius in a straight line.
 (2) inward to the centre along the radius in a straight line.
 (3) tangent to the circle in a straight line.
 (4) on a curved path outward from the circle.
 (5) along the same circular path continuously.

50. An ideal transformer (no energy loss) has 100 turns in the primary coil and 200 turns in the secondary coil. When the primary coil is connected to 120 V alternative supply, it gives 10 A current. Then the voltage / the current of the secondary is

- (1) 240 V / 2.5 A. (2) 240 V / 5 A. (3) 240 V / 10 A.
 (4) 120 V / 2.5 A. (5) 120 V / 5 A.

සියලු ම හිමිකම් ඇවිරිණි / முழுப் பதிப்புரிமையுடையது / All Rights Reserved

ශ්‍රී ලංකා විභාග දෙපාර්තමේන්තුව ශ්‍රී ලංකා විභාග දෙපාර්තමේන්තුව ශ්‍රී ලංකා විභාග දෙපාර්තමේන්තුව ශ්‍රී ලංකා විභාග දෙපාර්තමේන්තුව ශ්‍රී ලංකා විභාග දෙපාර්තමේන්තුව
இலங்கைப் பரீட்சைத் திணைக்களம் இலங்கைப் பரීட்சைத் திணைக்களம் இலங்கைப் பரීட்சைத் திணைக்களம் இலங்கைப் பரීட்சைத் திணைக்களம் இலங்கைப் பரීட்சைத் திணைக்களம்
Department of Examinations, Sri Lanka Department of Examinations, Sri Lanka Department of Examinations, Sri Lanka Department of Examinations, Sri Lanka Department of Examinations, Sri Lanka
ශ්‍රී ලංකා විභාග දෙපාර්තමේන්තුව ශ්‍රී ලංකා විභාග දෙපාර්තමේන්තුව ශ්‍රී ලංකා විභාග දෙපාර්තමේන්තුව ශ්‍රී ලංකා විභාග දෙපාර්තමේන්තුව ශ්‍රී ලංකා විභාග දෙපාර්තමේන්තුව
இலங்கைப் பரීட்சைத் திணைக்களம் இலங்கைப் பரීட்சைத் திணைக்களம் இலங்கைப் பரීட்சைத் திணைக்களம் இலங்கைப் பரීட்சைத் திணைக்களம் இலங்கைப் பரීட்சைத் திணைக்களம்

අධ්‍යයන පොදු සහතික පත්‍ර (උසස් පෙළ) විභාගය, 2016 අගෝස්තු
கல்விப் பொதுத் தராதரப் பத்திர (உயர் தர)ப் பரீட்சை, 2016 ஓகஸ்ட்
General Certificate of Education (Adv. Level) Examination, August 2016

තාක්ෂණවේදය සඳහා විද්‍යාව II
தொழினுட்பவியலுக்கான விஞ்ஞானம் II
Science for Technology II

67 E II

පැය තුනයි
மூன்று மணித்தியாலம்
Three hours

Index No. :

Instructions :

- * This question paper consists of 12 pages.
- * This question paper comprises of four Parts A, B, C and D. The time allotted for all parts is three hours.
- * Use of calculators is not allowed.

Part A - Structured Essay (08 pages)

- * Answer all the questions on this paper itself.
- * Write your answers in the space provided for each question. Note that the space provided is sufficient for your answers and that extensive answers are not expected.

Parts B, C and D - Essay (04 pages)

- * Select minimum of one question from each of the parts B, C and D and answer four questions only. Use the papers supplied for this purpose. At the end of the time allotted for this paper, tie all parts together so that Part A is on the top of Parts B, C and D before handing over to the supervisor.
- * You are permitted to remove only Parts B, C and D of the question paper from the examination hall.

For Examiners' Use Only

Part	Q. No.	Marks
A	1	
	2	
	3	
	4	
B	5	
	6	
C	7	
	8	
D	9	
	10	
Total		
Percentage		

Final Marks

In Numbers	
In Words	

Code Numbers

Marking Examiner 1	
Marking Examiner 2	
Checked by	
Supervised by	

Part A – Structured Essay

Answer all questions on this paper itself.

Do not write in this column

1. (a) The table given below shows some features of different groups of microorganisms. Complete the table by putting a tick (✓) if the groups of microorganisms has the given feature or a cross (×) if not.

Feature	Group of microorganisms		
	Bacteria	Fungi	Viruses
All in the group are unicellular.			
All in the group have eukaryotes cells.			
All in the group have DNA or RNA.			
All in the group have membrane bound organelles.			
Major component in the cell wall is peptidoglycan.			

- (b) Several steps in yoghurt production are briefly mentioned below.

Step 01	Collection of raw milk from farmers
Step 02	Pasteurization
Step 03	Adding starter culture at 40 °C to 45 °C temperature
Step 04	Incubation at 40 °C to 45 °C temperature
Step 05	Packaging

Answer the following questions using to the above information.

- (i) Why is it essential to pasteurize the raw milk in this process?

.....

- (ii) Why starter culture is being added only at 40 °C to 45 °C temperature range?

.....

- (iii) State the reason to include the incubation step in this manufacturing process.

.....

- (iv) Write **two** main steps in the milk thickening process?

(1)

(2)

- (c) Transgenic organisms can be produced using the recombinant DNA technology.

- (i) What are transgenic organisms?

.....

.....

.....

- (ii) Name enzymes used in recombinant DNA technology for steps (A) and (B) given below.

	Step	Enzyme
(A)	Cutting DNA at a specific site	
(B)	Combining two selected DNA fragments	

Do not
write
in this
column

0112

(iii) Consider the following dipeptide molecule. Three bonds in it are labelled as **P**, **Q** and **R**.

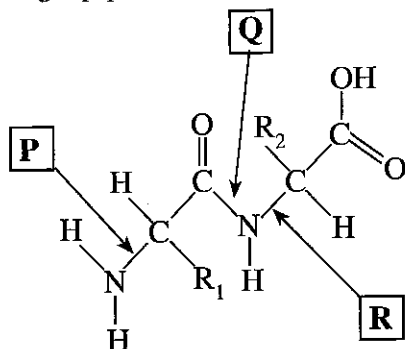

- (1) What is the letter in the label assigned for the peptide bond?
.....
- (2) Name the enzyme group that can be used to break the peptide bonds in protein.
.....
- (3) Name a test that can be used to identify the presence of peptide bonds in proteins.
.....

(d) Structures of some biomolecules named as **W**, **X**, **Y** and **Z** are given below.

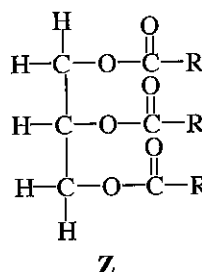
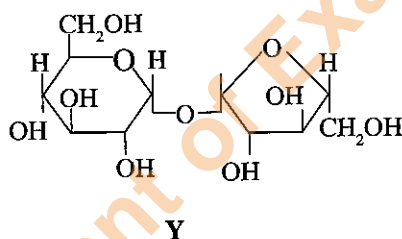
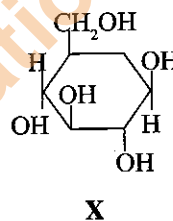
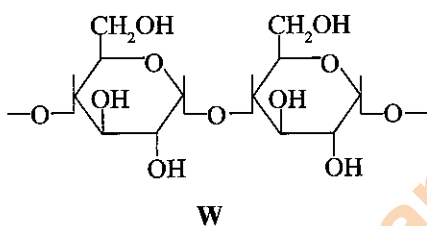

- (i) Name the reagent that can be used to identify the biomolecule named as **W**.
.....
- (ii) Which biomolecule mentioned above gives red colour in Sudan III test?
.....
- (iii) The structure of **X** belongs to which group of carbohydrates?
.....
- (iv) Name the reagent that could be used to identify the biomolecule **X** and write the colour of that reagent prior to the test.
.....
- (v) What colour confirms the presence of biomolecule **X** when it is tested with the reagent mentioned in (iv) above?
.....
- (vi) Which of the above biomolecules is present in beet root and sugar cane?
.....

Q.1

100

Do not write in this column

2. A fast food company has developed a self-heating cup with a special coating to keep the coffee warmer for a longer period of time. This cup also comes with a special lid to keep heat and water vapour trapped inside. CaO and H₂O are separately placed in a chamber located at the bottom to generate heat when mixed. Few cups were supplied to your school to test the effectiveness of the cup. The proposed experimental setup is shown in the figure.

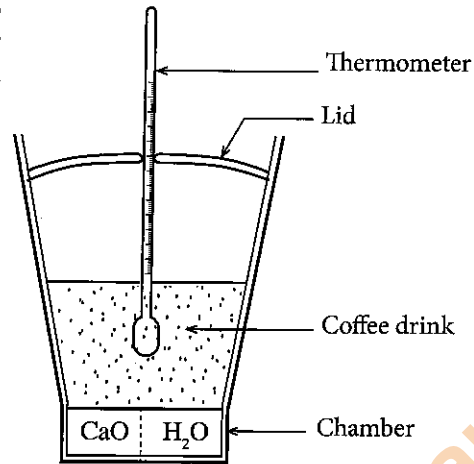

- (a) (i) Based on matter and energy exchange, which type of a system, a cup of hot coffee without a lid can be classified into?

 (ii) State **two** molecular level differences between liquid water and water vapour.

Liquid water	Water vapour
(1)
.....
(2)
.....

(b) The following chemical reaction is used to produce heat to keep coffee warm.

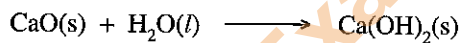

When 100 g of CaO is reacted with water to produce solid Ca(OH)₂, the amount of heat generated is 115.8 kJ. The self-heating cup is filled with 150 g of coffee drink and the lid with a thermometer is placed as shown in the above diagram. The temperature change with time from the start of the reaction is given in the table below. (Assume that the specific heat capacity of coffee drink is 4.3 J °C⁻¹ g⁻¹.)

Time(min)	Temperature(°C)	Time(min)	Temperature(°C)	Time(min)	Temperature(°C)
0.0	35	5.0	74.6	10.0	71.8
1.0	45	6.0	74.2	11.0	71.5
2.0	55	7.0	73.8	12.0	71.2
3.0	65	8.0	73.4	13.0	71.0
4.0	75	9.0	72.1	14.0	70.8

Answer the following questions using the above data.

- (i) Calculate the temperature increase due to the heat produced by the reaction.

- (ii) Mark the energy of reactants (CaO and H₂O) and the product (Ca(OH)₂) on the given energy levels.

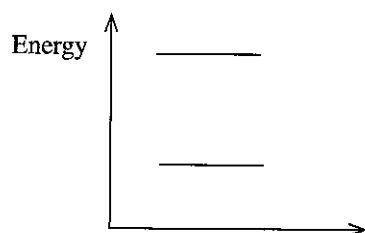

Do not write in this column

(iii) Calculate the amount of heat absorbed by the coffee drink.

.....

(iv) Calculate the mass of CaO used to build the self-heating cup, assuming all CaO in the cup is reacted with water and no heat loss to the surrounding.

.....

(v) Giving relevant steps, calculate the average rate of temperature decrease of coffee in the cup in °C/min for the last 10 minutes.

.....

(vi) What is the time taken to complete the reaction between CaO and H₂O?

.....

(vii) With the relevant steps, calculate the average consumption rate of CaO in g/min.

.....

Q.2

100

3. The potential divider circuit shown in the figure provides a variable potential difference (V_{AB}) across the terminals A and B. R is a 100 Ω rheostat with the sliding contact P, and E is a 6 V battery with a negligible internal resistance.

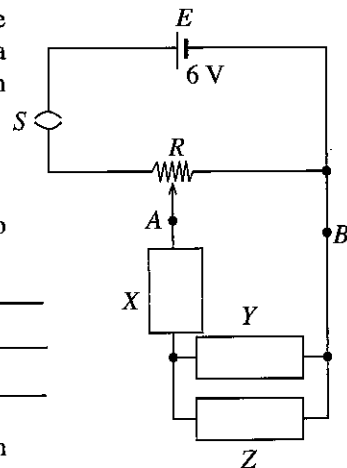

(a) You are provided the following items to plan an experiment to verify Ohm's law by using the given circuit.

- A nichrome wire with 8 Ω resistance.
- An ammeter with a negligible internal resistance.
- A voltmeter with a very high internal resistance

- (i) Complete the circuit diagram by connecting these items in the places shown as X, Y and Z in the figure in order to obtain the circuit employed for this experiment.
- (ii) Mark the positive terminals of the ammeter and the voltmeter in the circuit using the '+' sign.
- (iii) Calculate the maximum current flows through the nichrome wire when the circuit is closed.

.....

Do not write in this column

(iv) (1) Two ammeters with the maximum measurable currents 1 A and 10 A are provided. What is the suitable ammeter that can be used to measure the current flows through the circuit?

.....

(2) What is the reason for your selection?

.....

(v) Draw a rough sketch of the graph that you would expect from this experiment if the nichrome wire obeys Ohm's law.

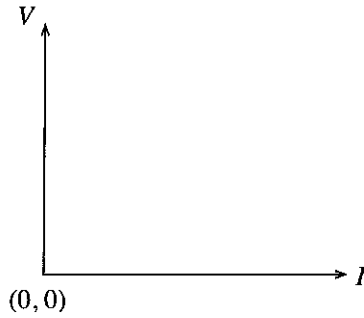

(b) The experiment was repeated after replacing the nichrome wire with a torch bulb in the above circuit. Then the graph obtained for V versus I is shown in the figure below.

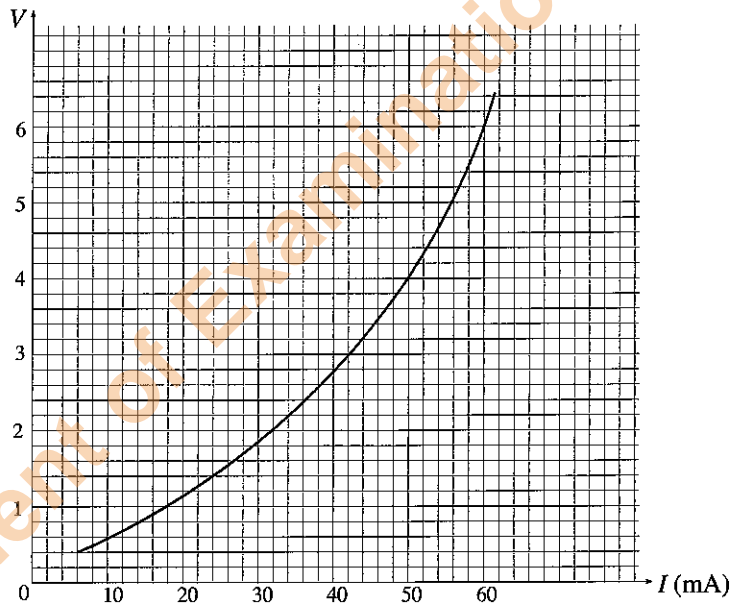

(i) The rating of the torch bulb is given as 6 V, 0.36 W. Explain the scientific basis of this rating.

.....

(ii) What is the reason for the deviation of the I - V characteristic of the filament from the Ohm's law?

.....

Department of Examinations Sri Lanka

Do not write in this column

(iii) (1) Calculate the resistance of the filament of the torch bulb and the current flowing through it when operating at the above recommended rating.

Resistance of the filament :

.....

Current through the bulb :

.....

(2) Mark the operating point of the bulb mentioned in (iii)(1) above on the curve in 3(b) with 'P' symbol.

(iv) At 18 °C temperature, the resistance of the filament of the bulb is 10 Ω. If the temperature coefficient of the resistance of the filament material is 0.0043 K⁻¹, calculate the temperature of the filament when it glows at its recommended rating.

.....

Q.3

100

4. An experimental set up to find the Young's modulus of rubber is shown in the following figure. The cross sectional area of the rubber tube is A . The initial separation of the tube between X and Y is l_0 . When a mass m is placed on the plate of balance, the point Y moves down and the new length of the rubber tube between X and Y becomes l . (Consider g as the gravitational acceleration.)

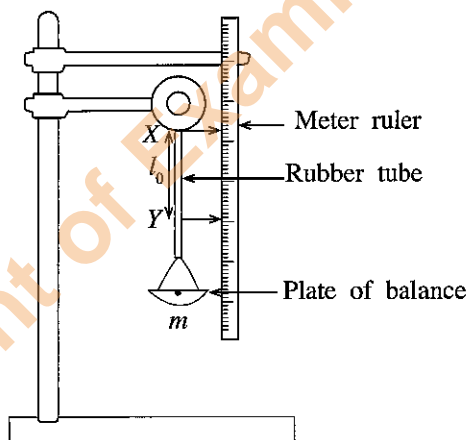

(a) Write down expressions for the tensile stress and the tensile strain of the rubber tube using the symbols given above.

Tensile stress :

Tensile strain :

(b) Obtain an equation that relates the tensile stress and the tensile strain using Hooke's law.

.....

(c) What are the variables measured in this experiment?

.....

(d) Rearrange the equation you obtained in 4(b) as an equation of a straight line.

.....

Do not write in this column

(e) Write the gradient and the intercept of the equation obtained in part 4(d) above.

Gradient :

Intercept :

(f) Draw a rough sketch of the graph using the equation obtained in part 4(d) above.

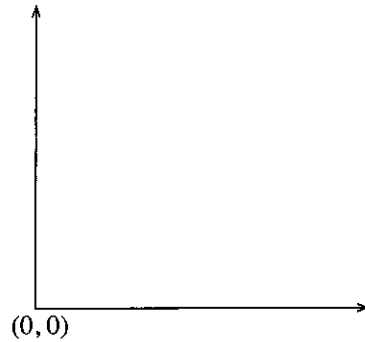

(g) (i) If the gradient of the above graph drawn in part 4(f) is G , obtain an expression for the Young's modulus of rubber.

.....

(ii) What are the readings of the rubber tube that required to calculate Young's modulus using the answer in part 4(g)(i) above?

.....

(iii) Write down the instruments with their least counts that can be used to obtain above three measurements in part 4(g)(ii).

Measurement	Instrument	Least count/mm

(h) Write an expression for the elastic potential energy stored in the rubber tube when some mass is applied to it. Draw a rough sketch of a graph to obtain it.

Elastic potential energy :

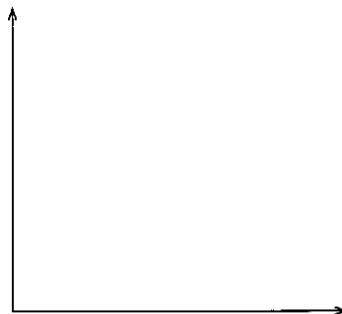

**

Q.4

100

මෙහි ම හිමිකම් ඇවිරිණි / முழுப் பதிப்புரிமையுடையது / All Rights Reserved

ශ්‍රී ලංකා විභාග දෙපාර්තමේන්තුව ශ්‍රී ලංකා විභාග දෙපාර්තමේන්තුව ශ්‍රී ලංකා විභාග දෙපාර්තමේන්තුව ශ්‍රී ලංකා විභාග දෙපාර්තමේන්තුව ශ්‍රී ලංකා විභාග දෙපාර්තමේන්තුව
 இலங்கைப் பரீட்சைத் திணைக்களம் இலங்கைப் பரීட்சைத் திணைக்களம் இலங்கைப் பரීட்சைத் திணைக்களம் இலங்கைப் பரීட்சைத் திணைக்களம் இலங்கைப் பரීட்சைத் திணைக்களம்
 Department of Examinations, Sri Lanka Department of Examinations, Sri Lanka Department of Examinations, Sri Lanka Department of Examinations, Sri Lanka Department of Examinations, Sri Lanka
 ශ්‍රී ලංකා විභාග දෙපාර්තමේන්තුව ශ්‍රී ලංකා විභාග දෙපාර්තමේන්තුව ශ්‍රී ලංකා විභාග දෙපාර්තමේන්තුව ශ්‍රී ලංකා විභාග දෙපාර්තමේන්තුව ශ්‍රී ලංකා විභාග දෙපාර්තමේන්තුව
 இலங்கைப் பரීட்சைத் திணைக்களம் இலங்கைப் பரීட்சைத் திணைக்களம் இலங்கைப் பரීட்சைத் திணைக்களம் இலங்கைப் பரීட்சைத் திணைக்களம் இலங்கைப் பரීட்சைத் திணைக்களம்
 Department of Examinations, Sri Lanka Department of Examinations, Sri Lanka Department of Examinations, Sri Lanka Department of Examinations, Sri Lanka Department of Examinations, Sri Lanka

අධ්‍යයන පොදු සහතික පත්‍ර (උසස් පෙළ) විභාගය, 2016 අගෝස්තු
 கல்விப் பொதுத் தராதரப் பத்திர (உயர் தர)ப் பரீட்சை, 2016 ஓகஸ்ட்
 General Certificate of Education (Adv. Level) Examination, August 2016

තාක්ෂණවේදය සඳහා විද්‍යාව II
 தொழினுட்பவியலுக்கான விஞ்ஞானம் II
 Science for Technology II

67 E II

Essay

Instructions:

- * Select minimum of one question each from parts B, C and D and answer four questions only.
- * Each question carries 15 marks.

Part B - Essay

5. (a) Standard length of a metal rod produced by a company should be 5 m. However, the metal rods with various lengths were reported. A random sample containing 20 rods was chosen and the length of each rod in centimetres are given below.

495	498	506	503	504	500	501	502	505	497
498	498	501	502	500	502	501	499	499	501

- Calculate the mean length of a rod?
 - Construct an ungrouped frequency distribution for the length of a metal rod. Include the cumulative frequencies also in the same table.
 - Calculate the mode and the median of the length of a metal rod. What can you conclude about the location of the data from these answers?
 - Calculate the first quartile (Q_1) and the third quartile (Q_3) for the length of a rod.
 - Calculate the inter quartile range for the length of a metal rod. From this calculated value, what can you conclude about the length variation of metal rods?
 - Construct a grouped frequency distribution for the length of a metal rod using class intervals 495 – 497, 498 – 500, Calculate the mean of the grouped frequency distribution using a suitable assumed mean. Include values required for the calculation in the same grouped frequency table.
- (b) Fasting blood sugar levels of 40 office employees are summarized in the table below.

Fasting blood sugar level (mg/dL)	Number of employees
60–79	6
80–99	8
100–119	13
120–139	5
140–159	4
160–179	3
180–199	1

- Draw a cumulative frequency curve for the data.
- What percentage of employees are having blood sugar level above 100.5 mg/dL?

6. The following questions are based on various geometrical shapes. Information that can be required for the calculations is provided at the end of the question. Give answers for calculations to the first decimal point.

(a) A sketch of a logo designed for a society is given in Figure (1). It consists of a regular hexagon and six semi-circles.

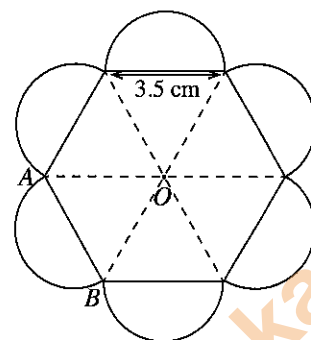

Figure (1)

(i) What is the value of $\hat{A}OB$?

(ii) Calculate the area of the logo showing the relevant steps.

(b) The data obtained to determine the height of a mountain are given in Figure (2). Calculate the height, CD of the mountain.

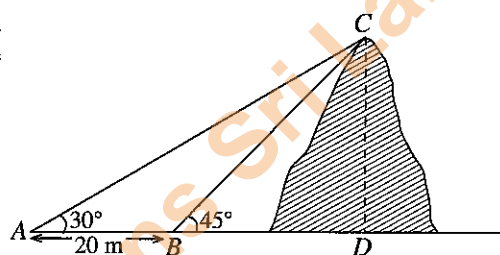

Figure (2)

(c) Calculate the area of the land $OABCD$ shown in Figure (3).

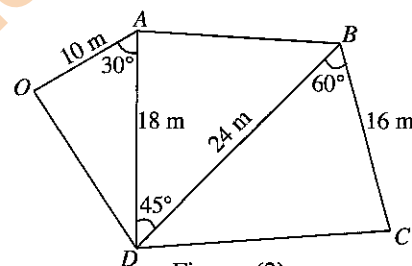

Figure (3)

(d) The length, the width and the height of a pencil box which has a cuboid shape are 16 cm, 4 cm and 3 cm respectively. What is the length of the longest pencil that can be kept inside this pencil box?

(e) A water tank consists of two cylindrical parts (A and C) and a part of a cone (B) as shown in Figure (4). Calculate the volume of the water tank, in terms of π .

Note :

$$\sqrt{3} = 1.73, \sqrt{2} = 1.41 \text{ and } \pi = \frac{22}{7}$$

	30°	45°	60°
sin	$\frac{1}{2}$	$\frac{1}{\sqrt{2}}$	$\frac{\sqrt{3}}{2}$
cos	$\frac{\sqrt{3}}{2}$	$\frac{1}{\sqrt{2}}$	$\frac{1}{2}$
tan	$\frac{1}{\sqrt{3}}$	1	$\sqrt{3}$

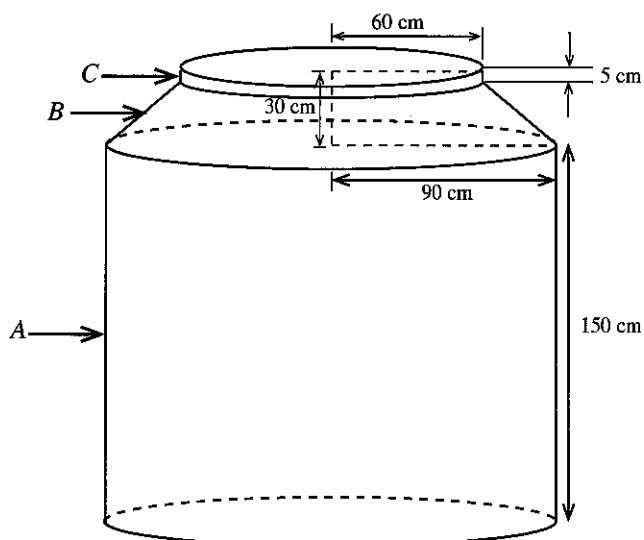

Figure (4)

Part C - Essay

7. Citronella oil is a natural product that can be found in lemon grass (*Cymbopogon* spp.) Steps of a method used for the extraction of citronella oil are shown below.

Extraction method

Step 01	Steam distillation of plant pieces.
Step 02	Collection of water mixture containing citronella oil.
Step 03	Extraction using a non-polar solvent.
Step 04	Evaporation of non-polar solvent.
Step 05	The product is tested using thin layer chromatography.

- (a) (i) What are natural products?
 (ii) Write **two** differences between primary and secondary metabolites.
 (iii) What is the main benefit of citronella oil to human?
 (iv) State the importance of Step 03.
 (v) Why the product is tested using thin layer chromatography?
 (vi) Give **two** advantages of biosynthesizing some compounds instead of producing them chemically.
- (b) A petroleum energy source is used for the above extraction process. In this process CO_2 , H_2O , NO_x , SO_x and unburnt hydrocarbons are produced. Some solid plant waste materials are also produced during this extraction process.
- (i) Name **two** greenhouse gases released during this process.
 (ii) Name **two** gases directly responsible for the acid rains, which are released during the above extraction process.
 (iii) What are the characteristics of gas molecules that can be absorb infrared rays?
 (iv) State **three** main objectives of Cleaner Production concept.
 (v) Briefly explain a method based on Cleaner Production concept to obtain the same product (citronella oil) by using the waste generated in the above extraction process to reduce the adverse effects on the environment.

8. The following flow chart shows how a few industrial processes interact with each other.

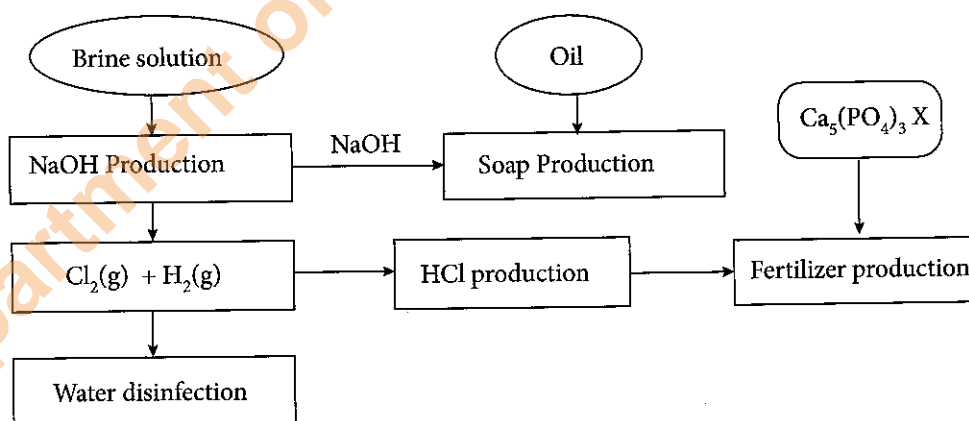

- (a) (i) State **three** natural raw materials used in these processes.
 (ii) Name **two** factors that must be considered when selecting natural raw materials for an industrial process.
 (iii) Why apatite is **not** suitable as a fertilizer for short term crops?
 (iv) Briefly explain how hydrochloric acid can be used to convert apatite into a fertilizer suitable for short term crops.
 (v) Explain **two** adverse effects on water bodies due to overuse of fertilizers.

- (b) (i) Explain the significance of the asbestos diaphragm in the production of sodium hydroxide using diaphragm cells.
- (ii) The diaphragm cell contains concentrated solutions of sodium hydroxide and brine. Name **two** water polluting agents present in this cell solution.
- (iii) Chlorination is one of the main methods used for water disinfection. State an advantage and a disadvantage of using chlorine over ozone for the water disinfection.
- (c) (i) State one structural difference between detergent and soap molecules.
- (ii) State an advantage and a disadvantage of using detergents over the use of soap.

Part D - Essay

9. (a) Write the relationship between real and apparent expansions of a liquid placed inside a vessel.
- (b) If a vessel is filled with a liquid of volume V and temperature of this system is increased by $\Delta\theta$, then the apparent expansion (V_A) and the real expansion (V_R) of the liquid are given by $V_A = V\gamma_A \Delta\theta$ and $V_R = V\gamma_R \Delta\theta$ respectively, where γ_A and γ_R are the coefficients of apparent and real volume expansions, respectively.
- (i) A volume of 120 cm^3 from a liquid with the coefficient of real volume expansion $2 \times 10^{-4} \text{ }^\circ\text{C}^{-1}$ is filled into a uniform cylindrical metallic vessel having the coefficient of linear expansion $2 \times 10^{-5} \text{ }^\circ\text{C}^{-1}$. Calculate the real expansion and the apparent expansion of the liquid when the temperature of the system is increased from $30 \text{ }^\circ\text{C}$ to $60 \text{ }^\circ\text{C}$.
- (ii) If the area of the bottom of the vessel is 12 cm^2 at $30 \text{ }^\circ\text{C}$, calculate the height of the liquid in the cylindrical vessel at $60 \text{ }^\circ\text{C}$.
- (iii) Calculate the amount of heat required to increase the temperature of the system from $30 \text{ }^\circ\text{C}$ to $60 \text{ }^\circ\text{C}$. (Consider the heat capacity of the vessel as $400 \text{ J }^\circ\text{C}^{-1}$, the density and the specific heat capacity of the liquid as 1200 kg m^{-3} and $4000 \text{ J kg}^{-1} \text{ }^\circ\text{C}^{-1}$, respectively.)
- (iv) A heating coil rated as 230 V , 1 kW is used to heat the system. Assuming that there is no heat exchange with the environment, calculate the time required to increase the temperature of the system from $30 \text{ }^\circ\text{C}$ to $60 \text{ }^\circ\text{C}$.
- (v) Calculate the resistance of the heating coil.
- (vi) When the supply voltage is dropped to 200 V , calculate the time required to produce the same temperature increase (from $30 \text{ }^\circ\text{C}$ to $60 \text{ }^\circ\text{C}$) of the system above.
- (vii) When the heating coil operating at the proper voltage, calculate the time required to vaporize the liquid completely at its boiling point. (The specific latent heat of vaporization of the liquid is 2000 kJ kg^{-1} .)
10. (a) State Archimedes' principle.
- (b) A small vessel with rectangular sides has 5 m^2 area of the bottom and 3 m height. The mass of empty vessel is 2560 kg . The demarcation line of the vessel, marked 2 m height from the bottom, indicates the maximum depth up to which the vessel can be floated safely in sea water with the density of 1020 kg m^{-3} .
- (i) Calculate the maximum mass that the vessel can be loaded to float safely.
- (ii) Calculate the extra mass that the vessel can bear just before sinking in sea water.
- (iii) The above vessel filled with metallic goods is immersed up to the demarcation line. It was noticed that oil was flowing into the vessel from outside with a rate of 0.1 m^3 per minute. If the relative density of oil is 0.75 , how long does the vessel floats on sea water before sinking? (The density of water is 1000 kg m^{-3} .)
- (iv) After sinking the vessel, cargo and oil fell out to the water. What is the minimum force required to lift the empty vessel to the surface of the sea from the ocean bed? (The density of the vessel is 2560 kg m^{-3} . The gravitational acceleration is, $g = 10 \text{ N kg}^{-1}$.)
- (v) What is the minimum work required to be done to lift the vessel 20 m up from the ocean bed? (Consider that the vessel is completely submerged in water throughout the lifting time.)
- (vi) Total time taken to perform the above task in part (b)(v) by a crane is 2 minutes and 40 seconds. The crane consumes electric energy at a rate of 5 kW . Calculate the efficiency of the crane.
- (vii) The risk of flipping over a ship increases with the height of the ship. Suggest a method to minimize the risk and explain it scientifically.