

සියලු ම හිමිකම් ඇවිරිණි / முழுப் பதிப்புரிமையுடையது / All Rights Reserved

ශ්‍රී ලංකා විභාග දෙපාර්තමේන්තුව ශ්‍රී ලංකා විභාග දෙපාර්තමේන්තුව ශ්‍රී ලංකා විභාග දෙපාර්තමේන්තුව ශ්‍රී ලංකා විභාග දෙපාර්තමේන්තුව ශ්‍රී ලංකා විභාග දෙපාර්තමේන්තුව
 இலங்கைப் பரீட்சைத் திணைக்களம் இலங்கைப் பரීட்சைத் திணைக்களம் இலங்கைப் பரීட்சைத் திணைக்களம் இலங்கைப் பரීட்சைத் திணைக்களம் இலங்கைப் பரීட்சைத் திணைக்களம்
 Department of Examinations, Sri Lanka Department of Examinations, Sri Lanka Department of Examinations, Sri Lanka Department of Examinations, Sri Lanka Department of Examinations, Sri Lanka
 ශ්‍රී ලංකා විභාග දෙපාර්තමේන්තුව ශ්‍රී ලංකා විභාග දෙපාර්තමේන්තුව ශ්‍රී ලංකා විභාග දෙපාර්තමේන්තුව ශ්‍රී ලංකා විභාග දෙපාර්තමේන්තුව ශ්‍රී ලංකා විභාග දෙපාර්තමේන්තුව
 இலங்கைப் பரීட்சைத் திணைக்களம் இலங்கைப் பரීட்சைத் திணைக்களம் இலங்கைப் பரීட்சைத் திணைக்களம் இலங்கைப் பரීட்சைத் திணைக்களம் இலங்கைப் பரීட்சைத் திணைக்களம்
 Department of Examinations, Sri Lanka Department of Examinations, Sri Lanka Department of Examinations, Sri Lanka Department of Examinations, Sri Lanka Department of Examinations, Sri Lanka

අධ්‍යයන පොදු සහතික පත්‍ර (උසස් පෙළ) විභාගය, 2017 අගෝස්තු
 கல்விப் பொதுத் தராதரப் பத்திர (உயர் தர)ப் பரீட்சை, 2017 ஔகஸ்த்
 General Certificate of Education (Adv. Level) Examination, August 2017

ජෛවපද්ධති තාක්ෂණවේදය I

உயிர்முறைமைகள் தொழினுட்பவியல் I
 Biosystems Technology I

66 E I

පැය දෙකයි

இரண்டு மணித்தியாலம்
 Two hours

Instructions:

- * Answer all the questions.
- * Write your **Index Number** in the space provided in the answer sheet.
- * Instructions are given on the back of the answer sheet. Follow them carefully.
- * In each of the questions 1 to 50, pick one of the alternatives from (1), (2), (3), (4), (5) which is **correct or most appropriate** and mark your response on the answer sheet with a cross (×) in accordance with the instructions given at the back of the answer sheet.
- * Use of calculators is not allowed.

1. One of the main objectives of the use of Biosystems Technology is to
 - (1) reduce waste.
 - (2) reduce the inputs.
 - (3) maximize the profit.
 - (4) achieve sustainability.
 - (5) reclaim the environment.
2. Following are some statements on the impacts of certain weather parameters on biosystems.
 - A - Increase in cloud cover increases paddy yield.
 - B - Decrease in cloud cover decreases the amount of phytoplankton in reservoirs.
 - C - Increase in day length increases poultry egg production.
 Of the above, the correct statement/s would be
 - (1) A only.
 - (2) B only.
 - (3) C only.
 - (4) A and B only.
 - (5) B and C only.
3. Infiltration in an area increases with the increase of
 - (1) slope of the area.
 - (2) clay content of soil.
 - (3) land cover of the area.
 - (4) wind speed of the area.
 - (5) moisture content of the soil.
4. The highest amount of hygroscopic water is found in
 - (1) loose clay soil.
 - (2) sandy loam soil.
 - (3) loose sandy soil.
 - (4) compacted clay soil.
 - (5) compacted sandy soil.
5. Salinization is prominent in
 - (1) an eroded soil of an arid region.
 - (2) an ill drained soil of a wet region.
 - (3) a well drained soil of a wet region.
 - (4) an ill drained soil of an arid region.
 - (5) a well drained soil of an arid region.
6. Following are two statements on contour lock and spill drains.
 - A - Soil retained in locks is removed and distributed down slope to the drain.
 - B - Lock in the drain is used to conserve water.
 Of the above statements,
 - (1) only A is correct.
 - (2) only B is correct.
 - (3) both A and B are correct.
 - (4) A is correct and B further explains A.
 - (5) B is correct and A further explains B.

- The following diagram shows a turning point (TP) of a profile levelling. Use the following diagram to answer the question No. 7.

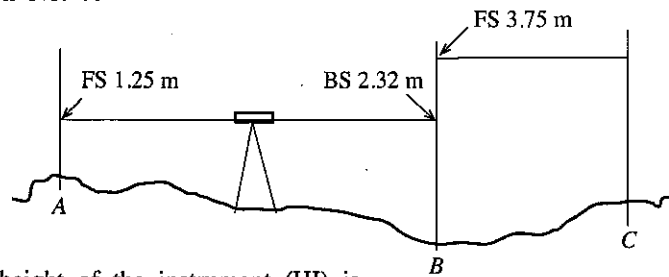

7. The difference in height of the instrument (HI) is,
 (1) $1.25 + 3.75$ m (2) $2.32 + 3.75$ m (3) $2.32 + 1.25$ m
 (4) $3.75 - 1.25$ m (5) $3.75 - 2.32$ m
8. In plane surveying Traversing is practiced when,
 (1) the land is sloping.
 (2) the land is undulating.
 (3) boundaries are not visible due to blocks.
 (4) the land is having a complicated shape.
 (5) instruments are not available to take angles.
9. Collimation error of a levelling instrument can be detected by
 (1) a tape. (2) two peg test. (3) an odometer.
 (4) Stadia method. (5) levelling with a spirit level.
10. An example for natural vegetative propagule is
 (1) seeds. (2) bulbils. (3) cuttings.
 (4) budded plants. (5) tissue cultured plants.
11. The main objective of the food and drug act is to
 (1) regulate the price of a food product.
 (2) ensure the safety of a food product.
 (3) reduce the packaging cost of a food product.
 (4) improve the attractiveness of a food product.
 (5) create new market opportunities for a food product.
12. Storing fruits at low temperature
 (1) increases enzymatic reactions. (2) increases water loss.
 (3) decreases appearance and taste. (4) increases postharvest disease incidents.
 (5) decreases damage caused by ethylene.
13. Quality of leafy vegetables can be maintained by applying
 (1) partially treated wastewater using sprinklers.
 (2) partially treated wastewater using flood irrigation.
 (3) agro-chemicals before harvesting to control pest attacks.
 (4) more potassium fertilisers to increase vegetative growth.
 (5) physical or mechanical measures to control weeds and pests.
14. Following statements are based on the vacuum packaging.
 A - It may help to reduce the transport and storage cost.
 B - A constant amount of air should be maintained within the package.
 C - Product should be completely sterilized before packaging.
- Of the above, the correct statement/s would be
 (1) A only. (2) B only. (3) C only.
 (4) A and B only. (5) B and C only.
15. Following statements are based on the sensory evaluation of a food product.
 A - It may help to control the price of a food product.
 B - It may help to develop the processing conditions of a food product.
 C - It may help to fulfil the requirements of the food act.
- Of the above, the correct statement/s would be
 (1) A only. (2) B only. (3) C only.
 (4) A and B only. (5) B and C only.

41. Most suitable time or day for harvesting of cut leaves and cut flowers would be
- (1) in the evening.
 - (2) bright sunny days.
 - (3) in the morning.
 - (4) morning of the bright sunny days.
 - (5) in the morning or in the evening.

● Use this diagram to answer the question No. 42.

42. The implement shown in this diagram is a
- (1) rotavator.
 - (2) seeder.
 - (3) harrow.
 - (4) weeder.
 - (5) inter-cultivator.

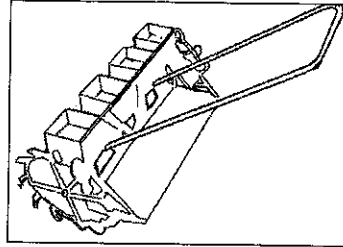

● Use this diagram to answer question No. 43.

43. The machine shown in this diagram is a
- (1) grass chopper.
 - (2) power sprayer.
 - (3) milking machine for cows.
 - (4) machine used to vacuum cattle yards.
 - (5) high pressure water pump used in washing barns.

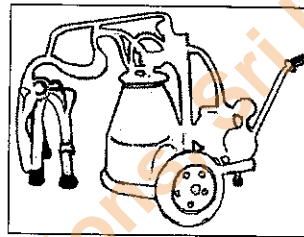

44. An advantage of aquaculture in terms of productivity compared to that of land systems is that the water environment
- (1) is abundant.
 - (2) has more nutrients.
 - (3) absorbs more energy from the sun.
 - (4) provides a three-dimensional growing space.
 - (5) has a stable temperature throughout the year.
45. *Tetrahymena* is a parasite commonly found in
- (1) fish feeds.
 - (2) marinated fish.
 - (3) marine aquariums.
 - (4) gut of the tuna fish.
 - (5) freshwater aquariums.
46. Sri Lanka has a high ecosystem diversity. Examples for ecosystems are
- (1) plants, animals and microbes.
 - (2) animals, forests and grasslands.
 - (3) grasslands, plants and microbes.
 - (4) forests, grasslands and inland wetlands.
 - (5) inland wetlands, animals and grasslands.
47. Alkaloids are
- (1) volatile plant oils.
 - (2) poisonous plant substances.
 - (3) found only in bark of the plant.
 - (4) highly volatile and found only in plants.
 - (5) naturally occurring nitrogenous compounds.
48. Examples for organic solvents used in volatile oil extraction are
- (1) hexane and acetone.
 - (2) acetone and liquid ammonia.
 - (3) liquid sulphur dioxide and hexane.
 - (4) liquid ammonia and liquid sulphur dioxide.
 - (5) di-methylene-chloride and sulfuryl chloride.
49. According to the recommendations of the International Labour Organization, the maximum workplace temperature for a light worker engaged in an 8 hour work shift should be
- (1) 25 °C.
 - (2) 27 °C.
 - (3) 29 °C.
 - (4) 31 °C.
 - (5) 33 °C.
50. Examples for employee related risks in small businesses are
- (1) theft, competitors enter market and loss of key suppliers.
 - (2) competitors enter market, high turnover and lack of training.
 - (3) market size shrinks, loss of key suppliers and employee disputes.
 - (4) high turnover, market size shrinks and equipment/tool breakdown.
 - (5) departure of a key employee, employee disputes and lack of training.

31. The basis of the sexed semen production lies on the
 (1) colour difference in X and Y chromosomes.
 (2) difference in the DNA content in X and Y chromosomes.
 (3) positive and negative charges present in X and Y chromosomes.
 (4) difference in the sensitivity of X and Y chromosomes to a laser beam.
 (5) difference in the response of X and Y chromosomes to a freezing temperature.
32. During the egg powder production, before spray drying, the egg whites are fermented to
 A - prevent the browning of egg powder due to Maylard's reaction.
 B - increase the shelf life of the egg powder.
 C - protect the nutrient against the high temperature in spray drying.
 Of the above, the correct statement/s would be
 (1) A only. (2) B only. (3) C only. (4) A and B only. (5) A and C only.
33. Eco-lodge is an important and attractive component in eco-tourism. The important features of an eco-lodge are, it
 (1) saves water and electricity and is built in an ecologically sensitive area.
 (2) is constructed using imported high quality materials and provides benefits to the people living in the nearby area.
 (3) is built in an ecologically sensitive area and facilitates tourists with information technology.
 (4) facilitates tourists with information technology and saves water and electricity.
 (5) uses environmental friendly material for construction and uses fossil fuel to generate electricity.
34. Following statements are based on the deep freezing and freeze drying.
 A - Deep freezing helps to immobilize the available free water.
 B - Freeze drying helps to remove available free water of food by sublimation.
 C - Both freeze drying and deep freezing immobilize the available free water of food within the system.
 Of the above, the correct statement/s would be
 (1) A only. (2) B only. (3) C only. (4) A and B only. (5) A and C only.
35. The average temperature-time combination used in the sterilization process of empty glass containers is
 (1) 70°C–30 minutes respectively. (2) 80°C–10 minutes respectively.
 (3) 80°C–30 minutes respectively. (4) 100°C–15 minutes respectively.
 (5) 100°C–30 minutes respectively.
36. The most suitable seed treatment for winged bean seeds would be
 (1) inoculation and soaking in water.
 (2) scarification and soaking in water.
 (3) covering with wood ash or fungicide.
 (4) inoculation and covering with wood ash.
 (5) scarification and covering with wood ash.
37. Appropriate polytunnel structure/s for low country is/are
 (1) arched type structure only. (2) top vent type structure only.
 (3) saw-tooth type structure only. (4) arched type and top vent type structures only.
 (5) top vent type and saw-tooth type structures only.
38. In a hydroponic culture system, crops are grown in a
 (1) hanging bag. (2) soil media. (3) grow bag.
 (4) soilless solid media. (5) liquid nutrient media.
39. Following are some of the major characteristics to be considered when selecting plant species for landscaping.
 A - small leaves.
 B - ornamental leaves
 C - thorny plants
 Of the above, the suitable characteristic/s of plants for hedge rows would be
 (1) A only. (2) A and B only. (3) A and C only. (4) B and C only. (5) All A, B and C.
40. Cut leaves industry brings foreign exchange to the country. The major cut leaves type/s exported from Sri Lanka would be
 (1) palm leaves. (2) croton leaves.
 (3) dracaena leaves. (4) palm and dracaena leaves.
 (5) croton and dracaena leaves.

22. Crop water requirement of a crop is 6 mm/day. The irrigation interval is 8 days. Five days after an irrigation which filled up to the field capacity, a rainfall of 42 mm was received. The effective rainfall received to field is
 (1) 48 mm. (2) 42 mm. (3) 30 mm. (4) 12 mm. (5) 7 mm.
23. When designing an irrigation system for a fruit crop, the capacity of the irrigation system should be calculated based on the water requirements of the crop at
 (1) the germination stage. (2) the vegetative stage.
 (3) the flowering stage. (4) the ripening stage.
 (5) all stages.
24. Water supplied to a crop field can be categorised as follows.
 A - Water retained in plants during crop growth
 B - Evaporation from field
 C - Seepage and percolation losses in the field
 D - Transpiration from plants
 E - Losses during conveyance
- Of the above, the water requirement of a crop includes
 (1) A, B and C only. (2) A, B, C and D only.
 (3) A, C, D and E only. (4) A, B, D and E only.
 (5) B, C, D and E only.
25. Compared to a surface irrigation system, a sub-surface irrigation system is more
 (1) durable. (2) labour intensive.
 (3) cheaper to install. (4) efficient in water application.
 (5) easier to operate and maintain.
26. Fungal diseases of a crop can be controlled by
 (1) spraying the Bordeaux mixture.
 (2) application of growth regulators.
 (3) spraying of a recommended insecticide.
 (4) spraying of a commonly used antibiotic.
 (5) application of Zinc Sulphate to the affected crop.
27. Crop rotation is considered as a
 (1) cultural pest control method.
 (2) biological pest control method.
 (3) method to encourage predators to control pest.
 (4) mechanical pest control method.
 (5) multiple cropping system to control pests.
28. Causal agent of pod borer damage of snake gourd is
 (1) *Fusarium* sp. (2) *Phytophthora* sp. (3) *Meloidogyne* sp.
 (4) *Dacus cucurbitae*. (5) *Rhizoctonia solani*.
29. Among the commonly available animal products, the highest protein content is found in
 (1) eggs. (2) pork. (3) cheese. (4) yoghurt. (5) chicken.
30. Following are a few statements about the closed house systems used in commercial broiler production in Sri Lanka.
 A - Per bird space in this system is lower than the per bird space in the open house systems.
 B - Automated environmental regulation inside the pens maintains a comfortable environment for birds.
 C - Automatic feeding systems are essential in closed houses.
- Of the above,
 (1) A and B are correct but C is incorrect.
 (2) B is correct but A and C are incorrect.
 (3) A, B and C are correct whereas B explains A.
 (4) A, B and C are correct whereas C explains A.
 (5) A, B and C are correct whereas B and C explain A.

16. The main factors that should be considered in determining the ratio of raw materials for a new food product formulation are

- (1) age group, height and weight of the people.
- (2) gender, age group and height of the people.
- (3) age group, weight and the economic level of the people.
- (4) gender, height and the specific nutritional requirements of the people.
- (5) gender, weight and the specific nutritional requirements of the people.

17. The most accurate analytical method for the determination of protein content of a food product is

- (1) Kjeldhal method.
- (2) Dye binding method.
- (3) Oven drying method.
- (4) Lane and Eynon method.
- (5) Soxhlet extraction method.

● A circuit diagram with a bulb that automatically switched on and off depending on light intensity is given in the following diagram. Use this diagram to answer question No. 18.

18. The transistor in this circuit is used

- (1) as a switch.
- (2) as a voltage amplifier.
- (3) to regulate the current.
- (4) to supply voltage to the LDR.
- (5) to protect the bulb from high currents.

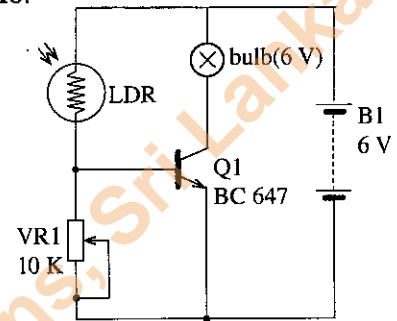

● Use the following diagram to answer question No. 19.

19. The component indicated by this symbol is found in

- (1) LDRs.
- (2) relays.
- (3) diodes.
- (4) capacitors.
- (5) transistors.



20. Aeration is done in treating groundwater, to

- (1) remove hardness.
- (2) assist in flocculation.
- (3) destroy anaerobic bacteria.
- (4) facilitate growth of bacteria.
- (5) remove dissolved metal ions.

● Following diagram shows a centrifugal pump installed to a well. Use this diagram to answer question No. 21.

21. The function of the component A in this pump system is to

- (1) control the water flow.
- (2) increase the pressure of delivery.
- (3) protect entering air from the inlet.
- (4) keep the pump primed all the time.
- (5) create more suction at the impeller.

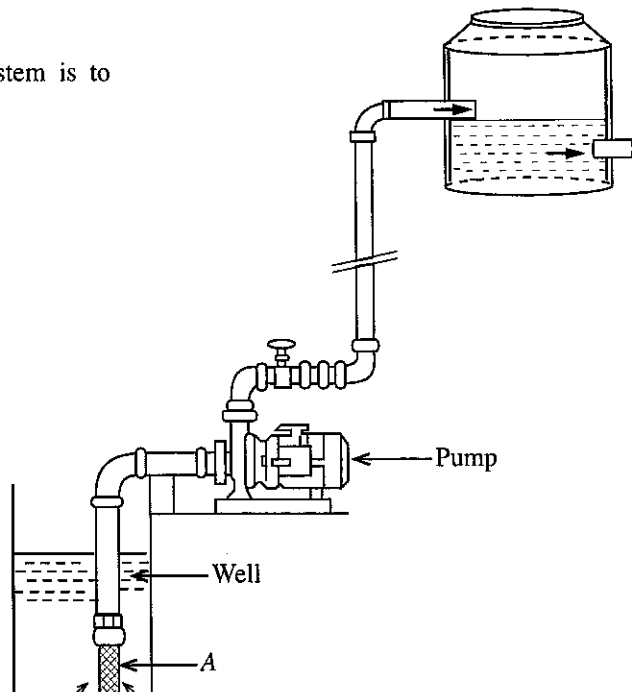

සියලු ම හිමිකම් ඇවිරිණි / முழுப் பதிப்புரிமையுடையது / All Rights Reserved

ශ්‍රී ලංකා විභාග දෙපාර්තමේන්තුව ශ්‍රී ලංකා විභාග දෙපාර්තමේන්තුව ශ්‍රී ලංකා විභාග දෙපාර්තමේන්තුව ශ්‍රී ලංකා විභාග දෙපාර්තමේන්තුව ශ්‍රී ලංකා විභාග දෙපාර්තමේන්තුව
இலங்கைப் பரீட்சைத் திணைக்களம் இலங்கைப் பரීட்சைத் திணைக்களம் இலங்கைப் பரීட்சைத் திணைக்களம் இலங்கைப் பரීட்சைத் திணைக்களம் இலங்கைப் பரීட்சைத் திணைக்களம்
Department of Examinations, Sri Lanka Department of Examinations, Sri Lanka Department of Examinations, Sri Lanka Department of Examinations, Sri Lanka Department of Examinations, Sri Lanka

අධ්‍යයන භෞත සහතික පත්‍ර (උසස් පෙළ) විභාගය, 2017 අගෝස්තු
கல்விப் பொதுத் தராதரப் பத்திர (உயர் தர)ப் பரீட்சை, 2017 ஓகஸ்ட்
General Certificate of Education (Adv. Level) Examination, August 2017

ජෛවපද්ධති තාක්ෂණවේදය II
உயிர்முறைமைகள் தொழினுட்பவியல் II
Biosystems Technology II

66 E II

පැය තුනයි
மூன்று மணித்தியாலம்
Three hours

Index No. :

Instructions :

- * This question paper comprises of two parts, Part A and Part B. The time allotted for both parts is three hours.

PART A – Structured Essay : (pages 2 - 6)

Answer all four questions on this paper itself. Write your answers in the space provided for each question. Note that the space provided is sufficient for your answers and that extensive answers are not expected.

PART B – Essay : (page 7)

- * Answer four questions only. Use the papers supplied for this purpose. At the end of the time allotted for this paper, tie the two parts together so that Part A is on top of Part B before handing them over to the Supervisor.

- * You are permitted to remove only Part B of the question paper from the Examination Hall.

For Examiner's Use Only

Part	Question Nos.	Marks Awarded
A	1	
	2	
	3	
	4	
B	5	
	6	
	7	
	8	
	9	
	10	
Total		
Percentage		

Final Marks

In numbers	
In words	

Code Numbers

Marking Examiner 1	
Marking Examiner 2	
Marks checked by	
Supervised by	

PART A – Structured Essay

Answer *all four* questions on this paper itself.

Do not write in this column

1. (A) Plantation forestry provides not only the economic benefits but social and ecological benefits also.

(i) List **two** plant species used in plantation forestry in Sri Lanka.

(1)

(2)

(ii) State **two** ecological benefits of plantation forestry.

(1)

(2)

(B) Sri Lanka has a distinct bimodal rainfall pattern mainly due to Northeast and Southwest monsoons.

(i) State the months that Sri Lanka receives the rains from each monsoon.

(1) Northeast monsoon

(2) Southwest monsoon

(ii) State a **negative** impact of bimodal rainfall pattern to biosystems.

.....

(C) A control system is regarded as a process that transforms one signal into another so as to give the desired system response.

(i) Write **two** examples of using an electromagnetic relay for operating devices in a control system used in biosystems.

(1)

(2)

(ii) State **two** important factors to be considered in connecting an LED in to a circuit of a control system.

(1)

(2)

(iii) Name **two** examples of sensors used in control systems in biosystems.

(1)

(2)

(D) Name *P*, *Q* and *R* terminals of the following electronic component.

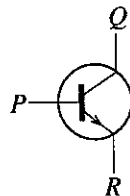

(i) *P*

(ii) *Q*

(iii) *R*

Do not write in this column

Q1

60

- (E) Proper management of a soil is important in maximizing the productivity of a land.
- (i) State **two negative** impacts that could be observed in a soil due to long term mono-cropping.
 - (1)
 - (2)
 - (ii) State **two** remedial measures to regain the sustainable productivity of a soil subjected to long term mono-cropping.
 - (1)
 - (2)
2. (A) Micro irrigation systems are used to minimize water losses during irrigation.
- (i) State **one** important component found in the control unit of an automated drip irrigation system.
 -
 - (ii) Pump is an important unit in micro irrigation. What could replace a pump in a small scale drip irrigation system?
 -
 - (iii) State **two** specific advantages of using drip irrigation systems compared to surface or sprinkler irrigation systems.
 - (1)
 - (2)
- (B) When water quality is poor, it affects not only aquatic life but the surrounding biosystem as well. Dissolved Oxygen (DO) is considered as one of the important parameters in measuring water quality.
- (i) State **two** factors that could change the Dissolved Oxygen level in water.
 - (1)
 - (2)
 - (ii) State **two undesirable** impacts of low Dissolved Oxygen levels in water on biosystems.
 - (1)
 - (2)
- (C) Time of harvesting of the day affects the quality of harvest which influences the shelf life and market price of agricultural produce.
- (i) State the appropriate time of the day to harvest following crops.
 - (1) Leafy vegetables:
 - (2) Mango:
- (D) A knowledge on type of crop damage is important in deciding a suitable pest control method.
- (i) State a suitable control measure for each of the insect group having following mouth parts.
 - (1) Piercing-sucking:
 - (2) Chewing:
 - (ii) Name **two** common insect pests having chewing mouth parts found in agricultural biosystems in Sri Lanka.
 - (1)
 - (2)

Do not write in this column

4. (A) Aquariums are structures having at least one transparent side in which water-dwelling plants or animals are kept and displayed.

(i) State **two** main advantages of keeping aquatic plants in aquariums.

(1)

(2)

(ii) Write **two** objectives of replacing water in aquariums.

(1)

(2)

(B) In artificial insemination, semen collected from a single ejaculate of a male animal is diluted to cross more female animals. List **two** properties of a medium used for semen dilution.

(i)

(ii)

(C) Diversified and value-added products are prepared from meats.

(i) Name **two** diversified meat products.

(1)

(2)

(ii) List **two** advantages of diversified food products.

(1)

(2)

(D) The role of tourist guides is very important to provide an attractive service to the eco-tourists. Name **two** essential qualities which should be possessed by a tourist guide to provide a good quality service.

(i)

(ii)

(E) Different thermo-chemical processes are involved in generating energy from biomass. Name **three** thermo-chemical processes used in energy production from biomass.

(i)

(ii)

(iii)

(F) Occupational Safety and Health related regulations were enacted by the government of Sri Lanka to help all employers and their workers to decrease job accidents, injuries, medical illnesses and death. Describe the following safety and health symbols.

(i) 

(ii) 

(iii) 

(iv) 

(v) 

Q4

60

සියලු ම හිමිකම් ඇවිරිණි / முழுப் பதிப்புரிமையுடையது / All Rights Reserved

ශ්‍රී ලංකා විභාග දෙපාර්තමේන්තුව ශ්‍රී ලංකා විභාග දෙපාර්තමේන්තුව ශ්‍රී ලංකා විභාග දෙපාර්තමේන්තුව ශ්‍රී ලංකා විභාග දෙපාර්තමේන්තුව ශ්‍රී ලංකා විභාග දෙපාර්තමේන්තුව
 இலங்கைப் பரீட்சைத் திணைக்களம் இலங்கைப் பரීட்சைத் திணைக்களம் இலங்கைப் பரීட்சைத் திணைக்களம் இலங்கைப் பரීட்சைத் திணைக்களம் இலங்கைப் பரීட்சைத் திணைக்களம்
 Department of Examinations, Sri Lanka Department of Examinations, Sri Lanka Department of Examinations, Sri Lanka Department of Examinations, Sri Lanka Department of Examinations, Sri Lanka
 ශ්‍රී ලංකා විභාග දෙපාර්තමේන්තුව ශ්‍රී ලංකා විභාග දෙපාර්තමේන්තුව ශ්‍රී ලංකා විභාග දෙපාර්තමේන්තුව ශ්‍රී ලංකා විභාග දෙපාර්තමේන්තුව ශ්‍රී ලංකා විභාග දෙපාර්තමේන්තුව
 இலங்கைப் பரීட்சைத் திணைக்களம் இலங்கைப் பரීட்சைத் திணைக்களம் இலங்கைப் பரīட்சைத் திணைக்களம் இலங்கைப் பரīட்சைத் திணைக்களம் இலங்கைப் பரīட்சைத் திணைக்களம்
 Department of Examinations, Sri Lanka Department of Examinations, Sri Lanka Department of Examinations, Sri Lanka Department of Examinations, Sri Lanka Department of Examinations, Sri Lanka

අධ්‍යයන පොදු සහතික පත්‍ර (උසස් පෙළ) විභාගය, 2017 අගෝස්තු
 கல்விப் பொதுத் தராதரப் பத்திர (உயர் தர)ப் பரீட்சை, 2017 ஓகஸ்ட்
 General Certificate of Education (Adv. Level) Examination, August 2017

ජෛවපද්ධති තාක්ෂණවේදය II

உயிர்முறைமைகள் தொழினுட்பவியல் II

Biosystems Technology II

66 E II

Part B - Essay

Instructions:

- * Answer four questions only.
- * Give clearly labelled diagrams where necessary.

5. (a) Describe the impacts of improper handling of livestock waste on ecosystems.
 (b) Describe the major characteristics to be considered in selecting Anthurium cut flowers for export market.
 (c) Describe the advantages and disadvantages of micro-propagation.
6. (a) With a labelled diagram, indicate the basic components of a simple biogas digester and describe the essential conditions to be maintained in the biogas digester for maximum biogas production.
 (b) Explain the importance of maintaining the proper environmental conditions in a protected plant house.
 (c) State different wetland ecosystems found in Sri Lanka and describe their importance in maintaining ecological balance.
7. (a) Describe the important factors to be considered in selecting a food fish species for cultivation in ponds.
 (b) Describe the methods to control invasive alien weeds.
 (c) Explain the main steps in extraction of volatile oil through steam distillation.
8. (a) Explain the reasons for the development of acidity in a soil.
 (b) With a labelled diagram, describe the functions of the important parts of an electric centrifugal pump.
 (c) Describe the methods of preservation of foods under low temperature conditions.
9. (a) If a farmer wants to mechanize the land preparation of his farm, describe the factors to be considered in selecting suitable machinery.
 (b) Describe the different types of occupational hazards.
 (c) A student collected the following data to calculate irrigation water requirement of a particular crop.
 Weekly pan evaporation is 42 mm
 Pan coefficient is 0.9
 K_c of flowering stage is 1.2
 Net irrigation requirement is 49.2 mm
 Gross irrigation requirement is 123 mm
 (i) Calculate the daily water requirement of the crop.
 (ii) Calculate the irrigation interval.
 (iii) Calculate the application efficiency.
10. (a) Calculate the area of the land shown in following diagram using the triangulation method.

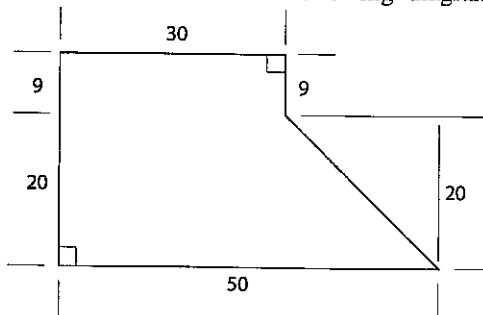

- (b) Explain the measures to be taken in packing perishables to minimize post-harvest losses.
- (c) Describe the tests that can be used for the sensory evaluation.

Department of Examinations, Sri Lanka

Department of Examinations, Sri Lanka