

ශ්‍රී ලංකා විභාග දෙපාර්තමේන්තුව ශ්‍රී ලංකා විභාග දෙපාර්තමේන්තුව ශ්‍රී ලංකා විභාග දෙපාර්තමේන්තුව ශ්‍රී ලංකා විභාග දෙපාර්තමේන්තුව ශ්‍රී ලංකා විභාග දෙපාර්තමේන්තුව  
 இலங்கைப் பரீட்சைத் திணைக்களம் இலங்கைப் பரීட்சைத் திணைக்களம் இலங்கைப் பரීட்சைத் திணைக்களம் இலங்கைப் பரීட்சைத் திணைக்களம் இலங்கைப் பரීட்சைத் திணைக்களம்  
 Department of Examinations, Sri Lanka Department of Examinations, Sri Lanka Department of Examinations, Sri Lanka Department of Examinations, Sri Lanka Department of Examinations, Sri Lanka  
 ශ්‍රී ලංකා විභාග දෙපාර්තමේන්තුව ශ්‍රී ලංකා විභාග දෙපාර්තමේන්තුව ශ්‍රී ලංකා විභාග දෙපාර්තමේන්තුව ශ්‍රී ලංකා විභාග දෙපාර්තමේන්තුව ශ්‍රී ලංකා විභාග දෙපාර්තමේන්තුව  
 இலங்கைப் பரීட்சைத் திணைக்களம் இலங்கைப் பரීட்சைத் திணைக்களம் இலங்கைப் பரීட்சைத் திணைக்களம் இலங்கைப் பரීட்சைத் திணைக்களம் இலங்கைப் பரීட்சைத் திணைக்களம்  
 Department of Examinations, Sri Lanka Department of Examinations, Sri Lanka Department of Examinations, Sri Lanka Department of Examinations, Sri Lanka Department of Examinations, Sri Lanka

අධ්‍යයන පොදු ජ්‍යෙෂ්ඨ පන්ති (උසස් පෙළ) විභාගය, 2017 අගෝස්තු  
 கல்விப் பொதுத் தராதரப் பத்திர (உயர் தரப் பரீட்சை, 2017 ஆகஸ்ட்)  
 General Certificate of Education (Adv. Level) Examination, August 2017

ඉංජිනේරු තාක්ෂණවේදය பொறியியற் தொழினுட்பவியல் <b>Engineering Technology</b>	I I I	<div style="border: 1px solid black; display: inline-block; padding: 5px; margin: 0 5px;">65</div> <div style="border: 1px solid black; display: inline-block; padding: 5px; margin: 0 5px;">E</div> <div style="border: 1px solid black; display: inline-block; padding: 5px; margin: 0 5px;">I</div>	පැය දෙකයි இரண்டு மணித்தியாலம் <b>Two hours</b>
--	-------------	--	--

**Instructions:**

- \* Answer **all** the questions.
- \* Write your **Index Number** in the space provided in the answer sheet.
- \* Instructions are given on the back of the answer sheet. Follow those carefully.
- \* In each of the questions **1 to 50**, pick one of the alternatives from (1), (2), (3), (4), (5) which is **correct or most appropriate** and mark your response on the answer sheet with a cross (x) in accordance with the instructions given at the back of the answer sheet.
- \* Each questions carries **03** marks totalling to **150**.
- \* Use of calculators is **not allowed**.

1. What is the standard unit of measurement of magnetic flux?  
 (1) Farad                      (2) Weber                      (3) Candela                      (4) Lux                      (5) Tesla
2. The following errors may occur in determining the external diameter of a circular cylinder.  
 A - Zero error of the measuring instrument  
 B - Errors of circularity of cylinder  
 C - Errors due to the way of obtaining measurements  
 What error or errors can be minimized by averaging several readings?  
 (1) A only.                      (2) B only.                      (3) C only.  
 (4) A and B only.                      (5) B and C only.
3. For the following object shown in isometric projection, which figure shows the correct orthogonal projections looking in the directions of arrows **A** and **B**? (figures are not drawn to scale)

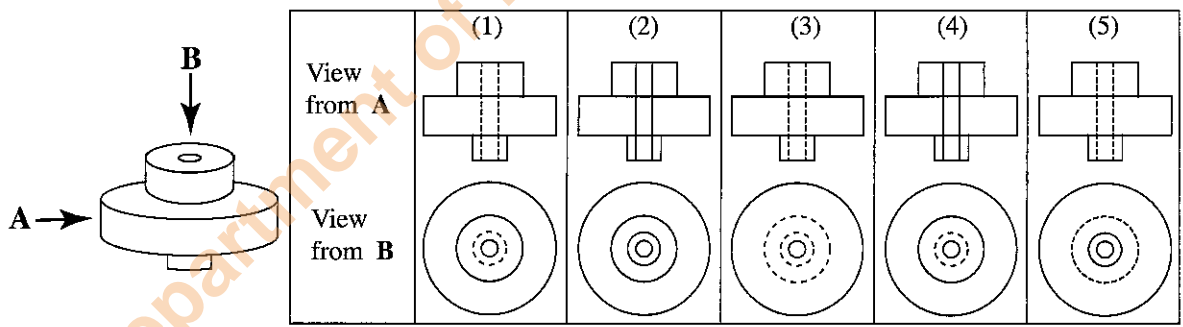

4. Which of the following statements are correct according to the present Institute of Electrical Engineers (IEE) wiring regulations for ring circuits?  
 A - Cable cross section area should be 2.5 mm<sup>2</sup>.  
 B - Area covered by the ring circuit should not exceed 100 m<sup>2</sup>.  
 C - Current rating of socket outlets should be 13 A.  
 D - Current rating of the overload protection device should be 32 A.  
 (1) A and B only.                      (2) C and D only.                      (3) A, B and D only.  
 (4) B, C and D only.                      (5) All A, B, C and D.
5. Which device is meant to operate immediately to disconnect the electrical supply, when a leakage occurs in a domestic electrical installation?  
 (1) Isolator  
 (2) Residual Current Circuit Breaker (RCCB)  
 (3) Miniature Circuit Breaker (MCB) in the relevant circuit  
 (4) Service Miniature Circuit Breaker  
 (5) Main Isolator

Department of Examinations, Sri Lanka

6. How much is the maximum current that is allowed for single phase domestic supply from the national electrical supply grid in Sri Lanka?  
 (1) 15 A                      (2) 30 A                      (3) 32 A                      (4) 40 A                      (5) 63 A
7. How much is the equivalent capacitance of six capacitors, each having a capacitance of 6 pF connected in series?  
 (1) 1 pF                      (2) 6 pF                      (3) 12 pF                      (4) 16 pF                      (5) 36 pF
8. How much is the line voltage and frequency of the three-phase electric supply in the national grid of Sri Lanka?  
 (1) 380 V and 50 Hz                      (2) 400 V and 50 Hz                      (3) 415 V and 50 Hz  
 (4) 400 V and 60 Hz                      (5) 415 V and 60 Hz
9. How much is the magnitude of the **minimum** alternating current that can cause instant death to a normal person?  
 (1) 0.001 A                      (2) 0.009 A                      (3) 0.01 A                      (4) 0.03 A                      (5) 0.1 A
10. What is the correct sequence of connection of Residual Current Circuit Breaker (RCCB), Miniature Circuit Breaker (MCB) and Isolator after Watt-hour meter?  
 (1) MCB, RCCB, Isolator                      (2) MCB, Isolator, RCCB  
 (3) Isolator, RCCB, MCB                      (4) RCCB, Isolator, MCB  
 (5) Isolator, MCB, RCCB
11. Listed below are three parameters relevant to a centrifugal pump.  
 A - Pumping flow rate of the fluid  
 B - Pumping head  
 C - Density of the pumping fluid  
 Out of the above parameters, the power consumed by the centrifugal pump depends on,  
 (1) A and B only.                      (2) A and C only.                      (3) B and C only.  
 (4) all of A, B and C.                      (5) none of the above.

12. If the value of the voltage between gate and source  $V_{GS}$  in the circuit is increased, select the right expression which describes the behaviour of the drain current  $I_D$  and voltage between drain and source  $V_{DS}$ .  
 (1)  $I_D$  will increase and  $V_{DS}$  will decrease.  
 (2) Both  $I_D$  and  $V_{DS}$  will increase.  
 (3)  $I_D$  will decrease and  $V_{DS}$  will increase.  
 (4) Both  $I_D$  and  $V_{DS}$  will decrease.  
 (5) Both  $I_D$  and  $V_{DS}$  will not change.

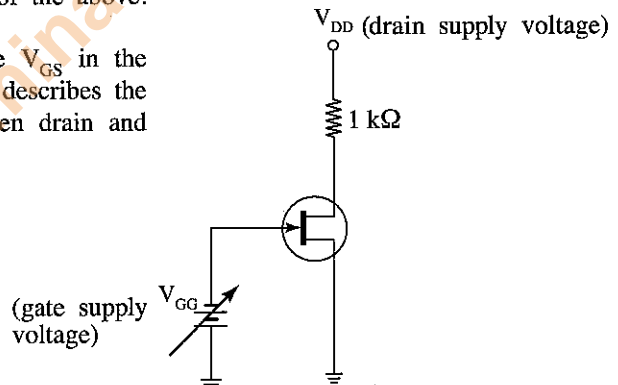

13. In a field effect transistor circuit, when the voltage between gate and source ( $V_{GS}$ ) is zero, for the drain current ( $I_D$ ) to become constant, what magnitude given below should be exceeded by the voltage between drain and source ( $V_{DS}$ )?  
 (1)  $V_{DD}$  (drain supply voltage)                      (2)  $V_p$  (pinch off voltage)                      (3) 0 V  
 (4) 0.7 V                      (5) 0.2 V

14. If  $V_{in}$  is the input waveform, what is the voltage waveform across the resistor  $R_L$  of the circuit shown in the figure?

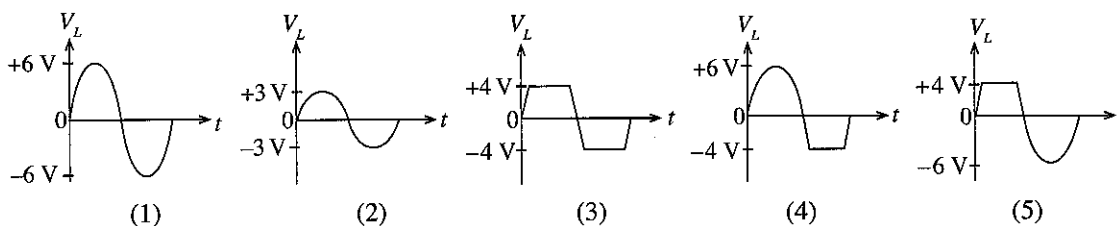
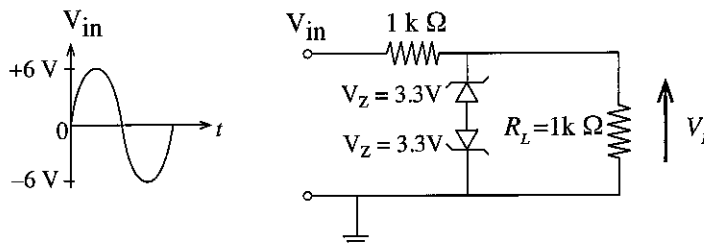

15. If  $V_{in}$  is the input waveform, what is the output waveform of the circuit shown in the figure?

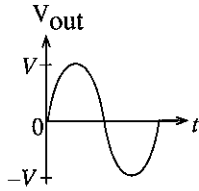
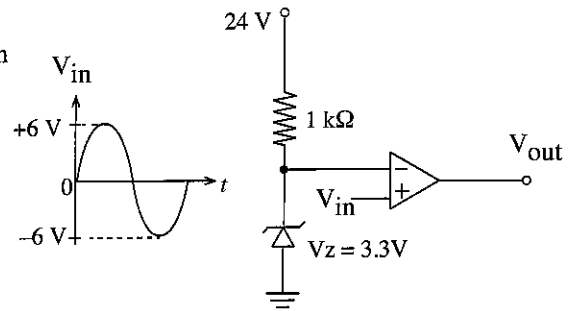

(1)

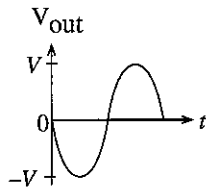

(2)

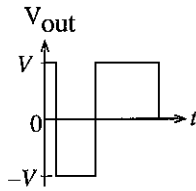

(3)

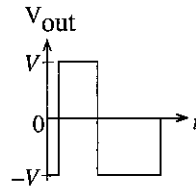

(4)

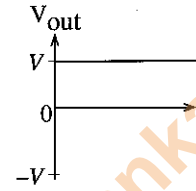

(5)

16. How much is the voltage gain of the op-amp circuit shown in the figure?

- (1) 0.1
- (2) 1
- (3) 9
- (4) 10
- (5) 11

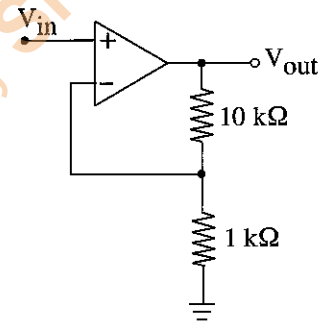

17. In frequency modulation, which parameter/s are varied according to the signal amplitude?

- (1) Amplitude only.
- (2) Frequency only.
- (3) Phase only.
- (4) Amplitude and frequency only.
- (5) Frequency and phase only.

18. Which is **not** a primary factor of an electric signal transmission line?

- (1) Resistance
- (2) Inductance
- (3) Capacitance
- (4) Conductance
- (5) Radiance

19. Figures show three digital circuits.

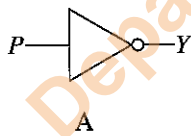

A

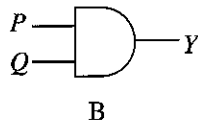

B

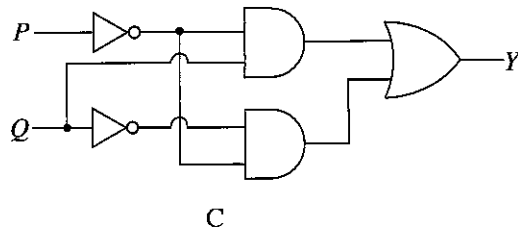

C

Out of them the digital circuits that represent/s  $Y = \bar{P}Q + P\bar{Q}$  Boolean expression is/are,

- (1) A only.
- (2) B only.
- (3) C only.
- (4) A and B only.
- (4) A and C only.

20. The following are several benefits from successful businesses.

- A - increase in the tax revenue
- B - ability to use innovative goods and services
- C - opportunities for increased income
- D - ability to influence the foreign market
- E - solution for unemployment

Out of the above benefits, the three direct benefits to the **society** are,

- (1) A, B and C.
- (2) A, B and D.
- (3) B, C and D.
- (4) B, C and E.
- (5) C, D and E.

21. Several qualities seen in an entrepreneur are stated below.

- A - Showing the correct direction to the followers.
- B - Allowing the followers to work as they wish.
- C - Ability to obtain the cooperation from the followers.
- D - Ability to set correct objectives for the business.
- E - Ability to get business objectives achieved by any means.

Out of the above qualities, the three **leadership** qualities are,

- (1) A, B and C. (2) A, C and D. (3) B, C and D. (4) B, C and E. (5) C, D and E.

22. A four-stroke spark ignition engine having a firing order of 1-3-4-2 operates under steady conditions at a speed of 3600 rpm. What is the approximate time gap between spark releases of cylinder number 2 and 3, in seconds?

- (1)  $\frac{1}{6}$  (2)  $\frac{1}{10}$  (3)  $\frac{1}{60}$  (4)  $\frac{1}{100}$  (5)  $\frac{1}{600}$

23. A four stroke engine produces 1.5 kW power when running at a rotation speed of 3000 rpm. How much is the engine output torque in Nm?

- (1)  $\frac{1}{2000}$  (2)  $\frac{1}{2}$  (3)  $\frac{7.5}{\pi}$  (4)  $\frac{15}{\pi}$  (5)  $\frac{60}{\pi}$

24. A vehicle pulls to a side during braking. Which one of the following is **not** a probable cause for this?

- (1) Leakage of braking fluid
- (2) Uneven tyre pressures
- (3) Stuck brake calipers
- (4) Worn-out suspension system components
- (5) Worn-out master cylinder of the breaking system

25. What could be the input-output speed ratios of a car at the first, second, third, fourth and fifth gears in sequence?

	First	Second	Third	Fourth	Fifth
(1)	3.35 : 1	2.05 : 1	1.48 : 1	1.36 : 1	0.94 : 1
(2)	0.94 : 1	1.36 : 1	1.48 : 1	2.05 : 1	3.35 : 1
(3)	$\frac{1}{3.35} : 1$	$\frac{1}{2.05} : 1$	$\frac{1}{1.48} : 1$	$\frac{1}{1.36} : 1$	$\frac{1}{0.94} : 1$
(4)	2.05 : 1	1.48 : 1	1.36 : 1	0.94 : 1	3.35 : 1
(5)	3.35 : 1	1.48 : 1	2.05 : 1	1.36 : 1	0.94 : 1

26. What is the **incorrect** statement with regard to the steering system of an automobile?

- (1) When a vehicle with Ackermann steering method, is turning to the left, the turning angle of front left wheel is more than that of the front right wheel.
- (2) Braking while turning could cause over-steer.
- (3) A recirculating ball gearbox is often used with rack and pinion steering mechanism.
- (4) Ackermann steering method is used with drop arm type steering mechanism.
- (5) Uneven tyre wear can be caused by a faulty tie rod.

27. What is the correct statement with regard to the cooling system in a motor car?

- (1) the radiator cap helps to keep the vapour pressure within the radiator lower than the atmospheric pressure.
- (2) coolant circulates always through the radiator when the engine is in operation.
- (3) the purpose of the overflow tank is to balance for the expansion and the contraction of the coolant.
- (4) it is due to convection that the coolant in the jackets of a liquid-cooled engine receives heat from the engine block.
- (5) ethylene glycol is used to increase the specific heat capacity of water-based engine coolants.

28. When starting an engine, it is found that the starter motor spins, but not the crankshaft. A reason for this is a faulty,

- (1) solenoid.
- (2) field coil.
- (3) Bendix mechanism.
- (4) stater coil.
- (5) motor control circuit.

29. What is the characteristic that is **undesirable** for cutting tools?

- (1) Hardness
- (2) Ductility
- (3) Toughness
- (4) Chemical inertness
- (5) Inelasticity

30. Which machine uses the reciprocating motion of the cutting tool for removing material?

- (1) Lathe machine
- (2) Grinding machine
- (3) Drilling machine
- (4) Shaping machine
- (5) Boring machine

31. A mass of 35 kg is placed on a hydraulic piston of diameter 100 mm. How much is the approximate hydraulic pressure developed inside the cylinder?

- (1)  $\frac{35 \times 9.81 \times 4}{3.14 \times 0.1^2}$  N/m<sup>2</sup>                      (2)  $\frac{35 \times 9.81 \times 3.14}{4 \times 0.1^2}$  N/m<sup>2</sup>  
 (3)  $\frac{35 \times 3.14}{9.81 \times 4 \times 0.1}$  N/m<sup>2</sup>                      (4)  $\frac{3.14 \times 0.1^2 \times 4}{35 \times 9.81}$  N/m<sup>2</sup>  
 (5)  $\frac{3.14 \times 0.1^2}{35 \times 9.81 \times 4}$  N/m<sup>2</sup>

32. A scissor jack is used to lift a load of 250 kg and is kept stationary as shown in the figure. What is the type of force acting along the axis of screw A?

- (1) Torsional force                      (2) Compressive force  
 (3) Tensile force                      (4) Shear force  
 (5) Traction force

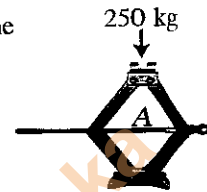

33. What is the purpose of having fins around the evaporator tubes used in refrigerators?

- (1) Efficiently remove ice                      (2) Increase the appearance  
 (3) Reduce the designing cost                      (4) Efficiently transfer heat  
 (5) Reduce the production cost

34. What is the function of the compressor in the vapour compression refrigeration cycle?

- (1) Increase the pressure of liquid refrigerant flowing through it.  
 (2) Increase the pressure of gaseous refrigerant flowing through it.  
 (3) Circulate air inside the refrigerator.  
 (4) Circulate water inside the refrigerator.  
 (5) Expel contaminated/toxic air that builds up inside the refrigerator.

35. Part of the stress strain curve for a steel reinforcement is shown in the figure.

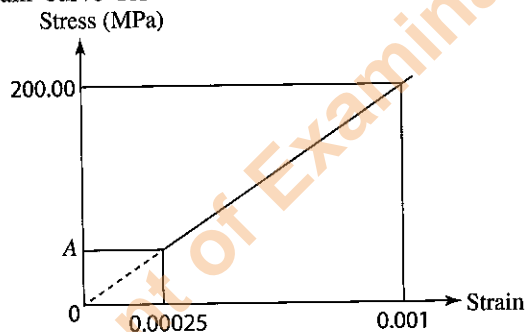

What is the value of stress at A ?

- (1) 50 N/mm<sup>2</sup>                      (2) 50 kN/mm<sup>2</sup>                      (3) 150 N/mm<sup>2</sup>                      (4) 200 N/mm<sup>2</sup>                      (5) 200 kN/mm<sup>2</sup>

36. Four brickbats are shown in the figures.

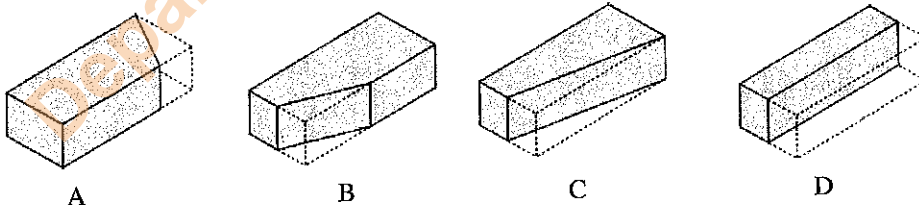

The brickbats marked as A, B, C and D are respectively,

- (1) mitred closer, bullnose brick, queen closer and half bat.  
 (2) king closer, mitred closer, half bat and queen closer.  
 (3) mitred closer, queen closer, bevelled closer and king closer.  
 (4) half bat, king closer, bullnose brick and queen closer.  
 (5) mitred closer, king closer, bevelled closer and queen closer.

37. A roof member connecting a hip rafter and a wall plate is called a,

- (1) common rafter.                      (2) valance board.  
 (3) short span rafter/jack rafter.                      (4) valley rafter.  
 (5) purlin.

Do not write in this column

- (b) (i) Write **two** categories of accidents that can take place when working on a scaffolding and state **two** precautions to be taken in erecting scaffoldings in order to prevent each of the accidents mentioned.

Accident	Precaution
(1) .....	.....
(2) .....	.....

(04 × 4 = 16 marks)

- (c) (i) According to ISO building design standards, state **three** features that should be incorporated in a multi-storey building to facilitate for people with physical disabilities.

- (1) .....  
 (2) .....  
 (3) .....

(04 × 3 = 12 marks)

- (ii) For long-term safe sustenance of reinforced concrete structures of a construction situated in the sea, special attention has to be paid to the various environmental conditions. State **two** such environmental conditions.

- (1) .....  
 (2) .....

(04 × 2 = 08 marks)

- (d) State **two** technological turning points that influenced the transformation of single-storey buildings to high-rise buildings.

- (1) .....  
 (2) .....

(04 × 2 = 08 marks)

Q 3

60

4. (a) Mr. Suranjan and Mr. Yoganathan operate a successful business for manufacturing and selling household water pumps under the brand name "S&Y" by using imported as well as local raw material.

- (i) Write **two** managerial tasks that may be included in each of the following management functions in managing this business:

Management Function	Managerial Task
Planning	(1) .....
	(2) .....
Organising	(1) .....
	(2) .....
Controlling	(1) .....
	(2) .....

(02 × 6 = 12 marks)

Do not write in this column

- (ii) The demand for “S & Y” water pumps is increasing due to high quality. Further, there is a decrease in the income levels of their customers and a rise in the prices of imported raw material. Under these circumstances alternatives have been proposed by the managers as shown in the table below. Indicate using (✓) the decisions that clearly reflect the entrepreneurial characteristics of Messrs. Suranjan and Yoganathan and the rest by using (×).

Decision	Correct (✓) wrong (×) entrepreneurial decision
Switching to a new market where a high price can be obtained.	
Abandon the business due to possibility of low profits or losses.	
Substitute local raw material in order to lower the prices while the securing existing quality.	
Limit the production quantity and increase the price to obtain profits.	

(02 × 4 = 08 marks)

- (iii) “S & Y” enterprise has already planned to expand its business using external financing sources. List out **three** main factors which need to be considered when comparing alternative external sources of financing.

- (1) .....
- (2) .....
- (3) .....

(02 × 3 = 06 marks)

- (iv) Classify stock of raw material, machinery and loan for buildings, into categories of long term liabilities, current assets or fixed (non-current) assets.

Category	Item
Long term liabilities	
Current assets	
Fixed (non-current) assets	

(02 × 3 = 06 marks)

- (b) (i) Information related to the demand and supply quantities of the “S & Y” water pumps is given, in the table below. Draw the demand and supply curves for “S & Y” water pumps in the grid, label them and mark the point of market equilibrium.

Unit Price (Rs.)	No. of Units	No. of Units
10,000	1,000	400
12,000	900	600
16,000	700	1,000
20,000	500	1,400

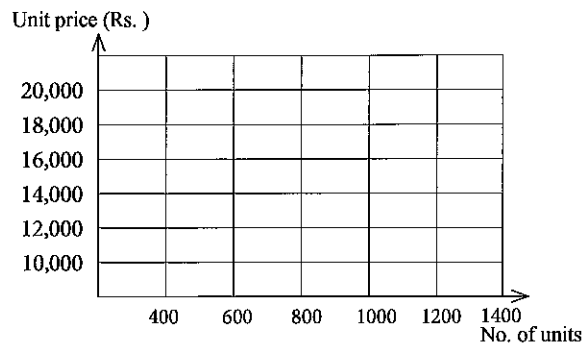

(06 marks)

Do not write in this column

(ii) Several events observed in the macro environment of “S&Y” enterprise are listed below. Name the basic category of macro environment related to each event in the table below.

Event	Macro environment factor category
Granting of tax concessions for importing water pumps	
General increase in the price levels of imported goods	
Discovery of new methods by scientists to produce water pumps	
Flooding of transport routes affecting the distribution of water pumps	
Increase in customer preference for locally produced goods	

(02 × 5 = 10 marks)

(c) The estimated financial information per annum related to “S&Y” enterprise is given below.

Description	Price/Units
Fixed cost	Rs. 480,000,000
Selling and distribution cost per unit (variable)	Rs. 2,000
Manufacturing cost per unit (variable)	Rs. 8,000
Selling price per unit	Rs. 18,000
Expected number of sales units	100,000

(i) Showing steps, calculate the estimated annual net profit of “S&Y” enterprise.

.....

.....

.....

.....

.....

.....

(04 marks)

(ii) Showing steps, calculate the break-even point in units of “S&Y” water pumps.

.....

.....

.....

.....

.....

(04 marks)

(iii) State **two** benefits that will flow to “S&Y” enterprise as a result of obtaining patent rights for “S&Y” water pumps.

(1) .....

(2) .....

(02 × 2 = 04 marks)

\* \*

Q. 4

60

සියලු ම හිමිකම් ඇවිරිණි / முழுப் பதிப்புரிமையுடையது / All Rights Reserved

ශ්‍රී ලංකා විභාග දෙපාර්තමේන්තුව ශ්‍රී ලංකා විභාග දෙපාර්තමේන්තුව ශ්‍රී ලංකා විභාග දෙපාර්තමේන්තුව ශ්‍රී ලංකා විභාග දෙපාර්තමේන්තුව ශ්‍රී ලංකා විභාග දෙපාර්තමේන්තුව  
 இலங்கைப் பரீட்சைத் திணைக்களம் இலங்கைப் பரීட்சைத் திணைக்களம் இலங்கைப் பரීட்சைத் திணைக்களம் இலங்கைப் பரීட்சைத் திணைக்களம் இலங்கைப் பரීட்சைத் திணைக்களம்  
 Department of Examinations, Sri Lanka Department of Examinations, Sri Lanka Department of Examinations, Sri Lanka Department of Examinations, Sri Lanka Department of Examinations, Sri Lanka  
 ශ්‍රී ලංකා විභාග දෙපාර්තමේන්තුව ශ්‍රී ලංකා විභාග දෙපාර්තමේන්තුව ශ්‍රී ලංකා විභාග දෙපාර්තමේන්තුව ශ්‍රී ලංකා විභාග දෙපාර්තමේන්තුව ශ්‍රී ලංකා විභාග දෙපාර්තමේන්තුව  
 இலங்கைப் பரීட்சைத் திணைக்களம் இலங்கைப் பரීட்சைத் திணைக்களம் இலங்கைப் பரීட்சைத் திணைக்களம் இலங்கைப் பரීட்சைத் திணைக்களம் இலங்கைப் பரීட்சைத் திணைக்களம்  
 Department of Examinations, Sri Lanka Department of Examinations, Sri Lanka Department of Examinations, Sri Lanka Department of Examinations, Sri Lanka Department of Examinations, Sri Lanka

අධ්‍යයන පොදු සහතික පත්‍ර (උසස් පෙළ) විභාගය, 2017 අගෝස්තු  
 கல்விப் பொதுத் தராதரப் பத்திர (உயர் தர)ப் பரீட்சை, 2017 ஓகஸ்து  
 General Certificate of Education (Adv. Level) Examination, August 2017

ඉංජිනේරු තාක්ෂණවේදය II  
 பொறியியற் தொழினுட்பவியல் II  
 Engineering Technology II

65 E II

**Instructions:**  
 \* Answer **four** questions only selecting at least **one** question each from parts B, C and D.  
 \* Marks allocated for each question is **90**.

**Part B - Essay (Electrical and Electronic Technology)**

5. (a) (i) State and describe the rule that relates the direction of rotation of a conductor, direction of the magnetic field and the direction of the induced electromotive force in an electrical generator. (05 marks)
- (ii) Explain the main difference between self-excited and separately excited generators. (10 marks)
- (iii) Describe **three** methods that can be used to increase the generated voltage of a DC generator. (15 marks)
- (b) (i) State **five** sources of renewable energy. (05 marks)
- (ii) Briefly explain how each of the renewable energy stated in part (b)(i) is converted to electric energy. (15 marks)
- (iii) State **two** main factors to be considered related to the water supply, in selecting the type of turbine for a hydro-power station. (10 marks)
- (c) (i) A 3 kW electric heater is used to heat water. If it is used for 2 hours per day, calculate the amount of electrical energy consumed in a 30 day month. (05 marks)
- (ii) According to Institute of Electrical Engineers (IEE) wiring regulations, persons and livestock shall be protected against dangers that may arise from contact with exposed-conductive parts. State **two** methods that can be used to achieve this requirement. (10 marks)
- (iii) Explain the functions of Isolator, Residual Current Circuit Breaker (RCCB) and Miniature Circuit Breaker (MCB) in a domestic electrical installation. (15 marks)
6. (a) (i) Compare and contrast the rectifier diode and the Zener diode. (06 marks)
- (ii) Illustrate using a circuit diagram, how a Zener diode can be used to regulate a varying DC voltage. (12 marks)
- (b) (i) Draw the transistor characteristic curves and mark the operating regions on it. (06 marks)
- (ii) Describe how to test whether a transistor is operating in the saturation region. (08 marks)
- (c) The figure shows a collector-feedback bias transistor circuit.

- (i) Explain that the above transistor **cannot** be biased into saturation region. (12 marks)
- (ii) Calculate the following:
  - I. Base current ( $I_B$ ) (16 marks)
  - II. Collector current ( $I_C$ ) (10 marks)
  - III. Collector voltage ( $V_C$ ) (10 marks)

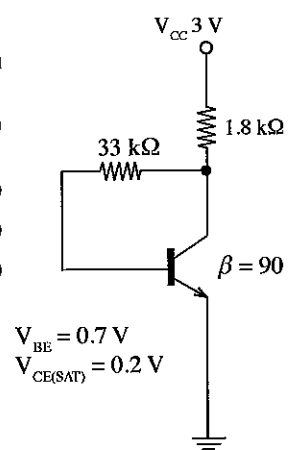



**Part D - Essay (Civil Technology)**

9. (a) Solid waste management adds an economic value to solid wastes which are regarded as useless. In most urban areas, solid waste is collected and dumped on a land located in a suburb.
- List **five** types of solid waste generated from households. (05 marks)
  - List **five** methodologies to manage solid waste at household level. (05 marks)
- (b) It is planned to construct a building for a solid waste management centre near a solid waste dump site. Following figure shows a 1 m wide section of the wall and its roof of solid waste management centre. Load from this section of the building is transferred to the foundation. A reinforced concrete strip foundation is to be designed for this building. Use the details given in the figure and data to answer the following questions.

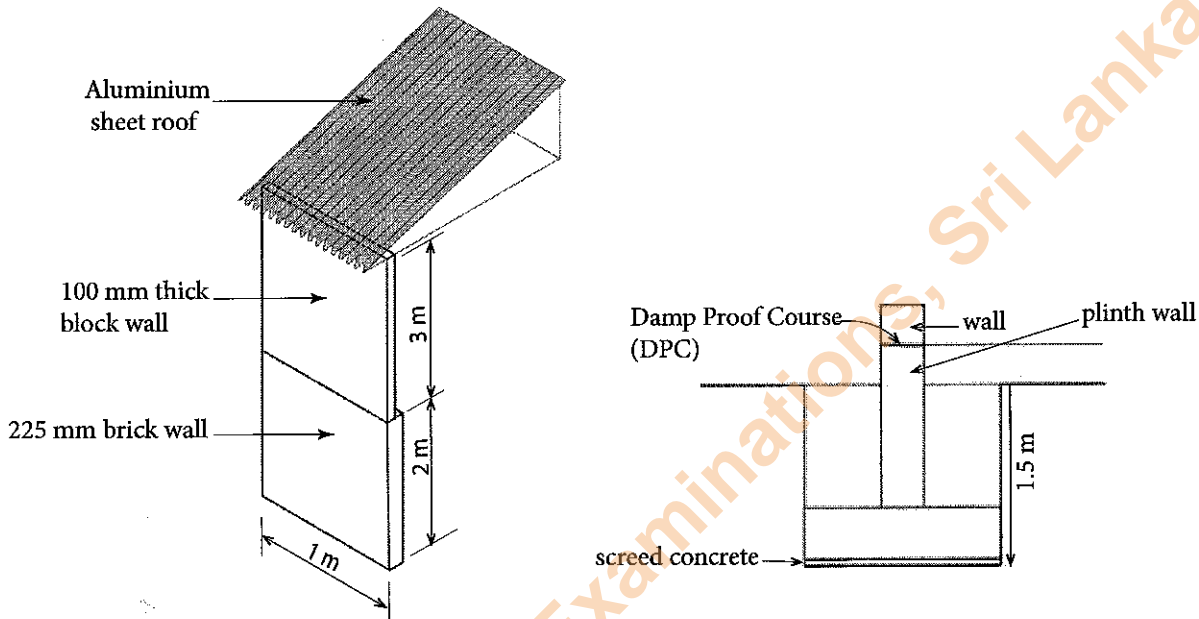

**Data:**

- Mass of 225 mm thick brick wall per square metre of face = 475 kg
- Mass of 100 mm thick block wall per square metre of face = 80 kg
- Mass of roof on one metre length of wall = 200 kg
- Gravitational acceleration = 9.81 m/s<sup>2</sup>

- Show the neutral axis and tension reinforcement of the reinforced concrete strip in a cross-section. (10 marks)
  - State **two** reasons for a screed concrete placed under the reinforced concrete strip. (10 marks)
  - Calculate the force acting on the foundation due to the weight of the one metre long section of the building shown. (15 marks)
  - State **one** consequence each if the bearing capacity of the soil is over estimated or under estimated. (10 marks)
  - State **three** functions of the roof of the above building. (15 marks)
  - State **five** types of roofs identifiable according to the structural forms. (10 marks)
- (c) Paint is a typical finishing applied to the walls of building. Describe the functions of the 'base' and 'carrier' components of paints. (10 marks)

10. (a) There is a proposal to construct a wood workshop on a plot of land. The land extent covered with boundary points A, B, C, D, and E were surveyed with a survey line AE and the perpendicular offsets were as follows:

Boundary Point	A	B	C	D	E
Distance from 'A' along the survey line (m)	0	20	40	60	80
Perpendicular offsets (m)	0	10 (right)	10 (left)	20 (right)	0

- (i) Explain the principle of chain surveying. (05 marks)
- (ii) Draw a rough plan of the land using the above offsets indicating all the measurements. (10 marks)
- (iii) Showing the steps, calculate the area of the above land. (15 marks)
- (b) Plan view of a proposed wood workshop is shown in the figure. This building has a flat roof made up of a concrete slab. The bottom surface of the concrete slab is 3000mm above the damp proof course (DPC) level. (All dimensions are in millimetres.)

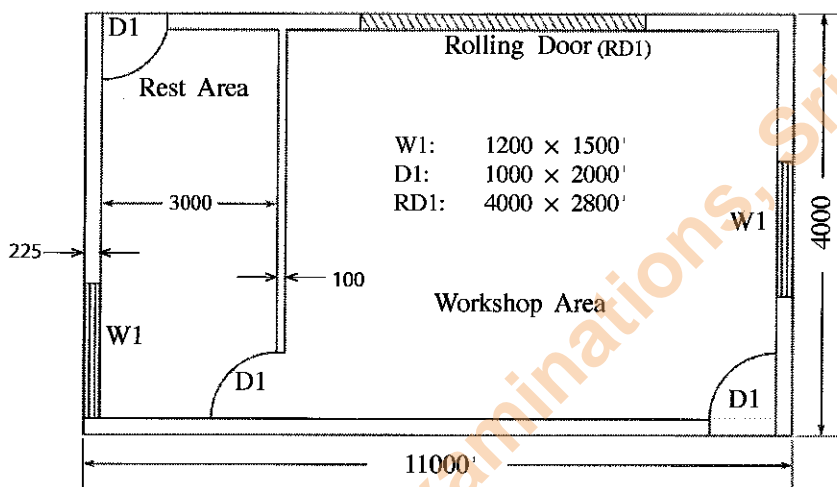

- (i) Determine the centerline girth of the external walls. (15 marks)
- (ii) Determine the centerline length of the internal walls. (05 marks)
- (c) Using the supplied TDS sheets, calculate the following quantities according to SLS 573:1999.
- (i) Showing deductions for openings, 225 mm thick external walls ( $m^2$ ) from the DPC level to bottom of the slab. (10 marks)
- (ii) Showing deductions for openings, 100 mm thick internal walls ( $m^2$ ) from the DPC level to bottom of the slab. (10 marks)
- (iii) 100 mm thick concrete ( $m^3$ ) for the floor of the workshop area. (10 marks)
- (d) Write five overhead costs applicable to the above civil engineering construction. (10 marks)

\*\*\*