

ශ්‍රී ලංකා විභාග දෙපාර්තමේන්තුව ශ්‍රී ලංකා විභාග දෙපාර්තමේන්තුව ශ්‍රී ලංකා විභාග දෙපාර්තමේන්තුව ශ්‍රී ලංකා විභාග දෙපාර්තමේන්තුව ශ්‍රී ලංකා විභාග දෙපාර්තමේන්තුව
 இலங்கைப் பரீட்சைத் திணைக்களம் இலங்கைப் பரීட்சைத் திணைக்களம் இலங்கைப் பரීட்சைத் திணைக்களம் இலங்கைப் பரීட்சைத் திணைக்களம் இலங்கைப் பரීட்சைத் திணைக்களம்
 Department of Examinations, Sri Lanka Department of Examinations, Sri Lanka Department of Examinations, Sri Lanka Department of Examinations, Sri Lanka Department of Examinations, Sri Lanka
 ශ්‍රී ලංකා විභාග දෙපාර්තමේන්තුව ශ්‍රී ලංකා විභාග දෙපාර්තමේන්තුව ශ්‍රී ලංකා විභාග දෙපාර්තමේන්තුව ශ්‍රී ලංකා විභාග දෙපාර්තමේන්තුව ශ්‍රී ලංකා විභාග දෙපාර්තමේන්තුව
 இலங்கைப் பரීட்சைத் திணைக்களம் இலங்கைப் பரීட்சைத் திணைக்களம் இலங்கைப் பரීட்சைத் திணைக்களம் இலங்கைப் பரීட்சைத் திணைக்களம் இலங்கைப் பரීட்சைத் திணைக்களம்
 Department of Examinations, Sri Lanka Department of Examinations, Sri Lanka Department of Examinations, Sri Lanka Department of Examinations, Sri Lanka Department of Examinations, Sri Lanka

අධ්‍යයන පොදු සහතික පත්‍ර (උසස් පෙළ) විභාගය, 2018 අගෝස්තු
 கல்விப் பொதுத் தராதரப் பத்திர (உயர் தர)ப் பரீட்சை, 2018 ஆகஸ்ட்
 General Certificate of Education (Adv. Level) Examination, August 2018

14.08.2018 / 13 00 - 15 00

විදුලිය, ඉලෙක්ට්‍රොනික හා තොරතුරු තාක්ෂණවේදය I
 மின், இலத்திரன், தகவல் தொழினுட்பவியல் I
 Electrical, Electronic and Information Technology I

16 E I

පැය දෙකයි
 இரண்டு மணித்தியாலம்
 Two hours

Instructions:

- * Answer *all* the questions.
- * Write your **Index Number** in the space provided in the answer sheet.
- * Use of calculators is not allowed.
- * Instructions are given on the back of the answer sheet. Follow those carefully.
- * In each of the questions 1 to 50, pick one of the alternatives from (1), (2), (3), (4), (5) which is **correct** or **most appropriate** and mark your response on the answer sheet with a cross (x) in accordance with the instructions given in the back of the answer sheet.

1. Young's modulus of steel is 1.9×10^{10} N/m². $1\text{N} = 10^5$ cm g/s². How is this value expressed in CGS (Centimetre, Gram, Second) units?

- (1) 1.9×10^9 (2) 1.9×10^{10} (3) 1.9×10^{11} (4) 1.9×10^{12} (5) 1.9×10^{13}

2. Figure shows a mercury column in a simple barometer.

- A - The height H depends on the atmospheric pressure.
 B - H is approximately equal to 760 mm.
 C - The presence of water above the mercury surface in the column increases the height H .
 D - The height H is an indicator of the maximum suction head when pumping water from a well.

Which of the above statements are true?

- (1) A, B and C only. (2) A, B and D only.
 (3) A, C and D only. (4) B, C and D only.
 (5) A, B, C and D all.

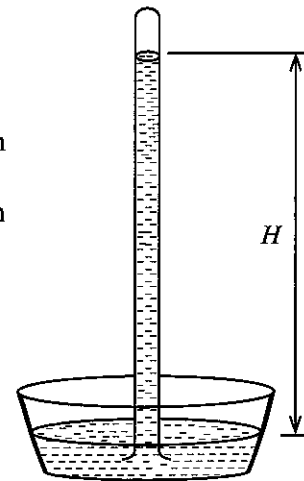

Figure

3. Consider the following statements that describe certain chemicals.

- A - A standard motor car battery has Sulfuric Acid and Lead.
 B - Soap molecule can attract water at one end, and oil at the other.
 C - Toilet bowl cleaning liquid has Sodium Hypochlorite.
 D - Salt helps to relax cramped muscles.

Which of the above statements describe a chemical used at home?

- (1) A, B and C only. (2) A, B and D only. (3) A, C and D only.
 (4) B, C and D only. (5) A, B, C and D all.

4. Which of the following actions demonstrate entrepreneurship traits of an owner of a family that owns a restaurant?

- A - The use of close circuit television cameras to cover the restaurant area
 B - Eldest daughter managing the cashier desk
 C - Using a separate freezer for ready-to-use fish and meat stocks
 D - Assigning two employees daily to clean and disinfect the kitchen area and the rest rooms twice a day

- (1) A, B and C only. (2) A, B and D only. (3) A, C and D only.
 (4) B, C and D only. (5) A, B, C and D all.

5. A pulley arrangement is shown to lift 100 N (approximately equal to 10 kg) as shown in the figure. Each pulley has a weight of 10 N (approximately equal to 1 kg). Force P , required for the equilibrium of the system is
- (1) 20 N.
 - (2) 22.5 N.
 - (3) 25 N.
 - (4) 27.5 N.
 - (5) 50 N.

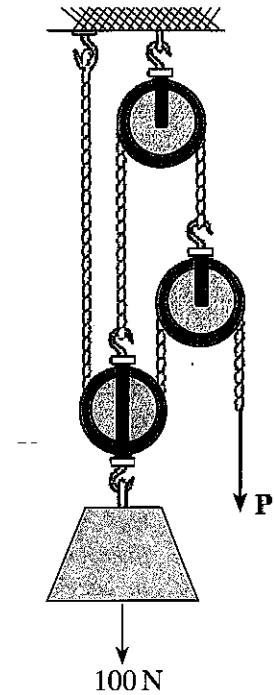

6. A steel truss is used to support a load at point C as shown in the figure.

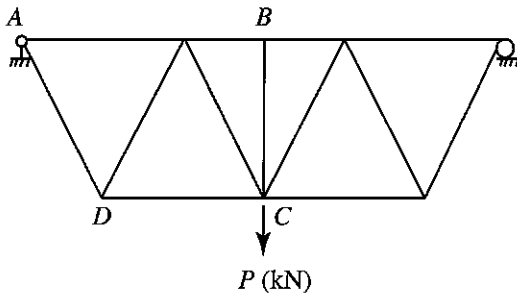

Consider the following statements on the steel truss given in the figure.

- A - All top chord members carry compressive forces.
- B - All bottom chord members carry tensile forces.
- C - Member BC is not required to maintain stability.
- D - Member AD carries a tensile force.

Which of the above statements are true?

- (1) A, B and C only.
 - (2) A, B and D only.
 - (3) A, C and D only.
 - (4) B, C and D only.
 - (5) A, B, C and D all.
7. Two cylindrical steel specimens, A and B , with similar length and diameter were subjected to a continuous load until failure. Specimen A failed at a load of 1200 kN with an elongation of 2.1 mm. Specimen B failed at a load of 1350 kN with an elongation of 1.9 mm.
- A - Specimen A is more ductile than B .
 - B - Specimen B is more ductile than A .
 - C - Specimen A has a higher ultimate tensile strength than B .
 - D - Specimen B has a higher ultimate tensile strength than A .

Which of these statements are true?

- (1) A and C only.
 - (2) A and D only.
 - (3) B and C only.
 - (4) B and D only.
 - (5) None of above.
8. A van travels along a straight road from points A to B , and its velocity versus time graph is shown in the figure. The total distance it travelled is

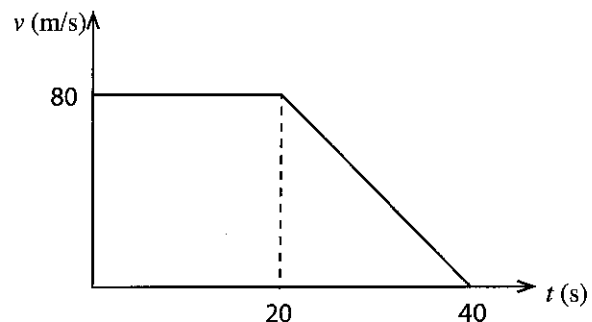

- (1) 1.8 km.
- (2) 2.0 km.
- (3) 2.4 km.
- (4) 2.6 km.
- (5) 2.8 km.

9. A uniform crate has a weight of 500 N (approximately equal to 50 kg) and it is pushed with a force of 200 N as shown in the Figure. Coefficient of static friction between the crate and ground is 0.3.

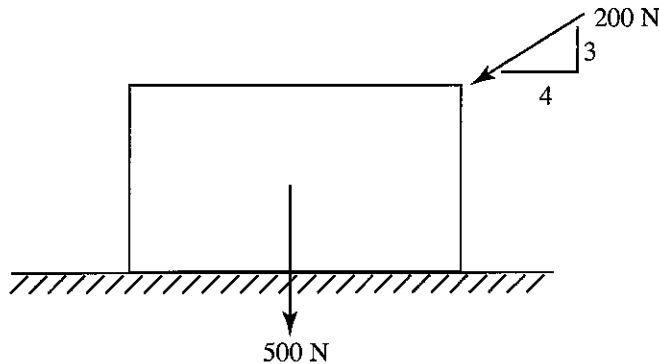

The friction force at the limiting equilibrium state is

- (1) 186 N. (2) 195 N. (3) 200 N. (4) 260 N. (5) 500 N.
- Following figure shows a measurement of a steel rod taken from a vernier calliper. Use the figure to answer questions 10 and 11.

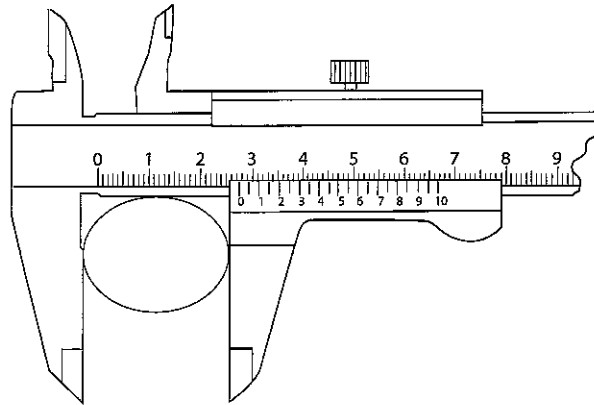

10. What is the minimum reading of the vernier calliper in mm?
- (1) 0.005 (2) 0.01 (3) 0.02 (4) 0.05 (5) 0.1
11. What is the diameter of the steel rod?
- (1) 2.75 cm (2) 2.80 cm (3) 2.55 cm (4) 2.59 cm (5) 2.42 cm
12. Which of the following describes the scale in nanotechnology?
- (1) 0 mm – 100 mm (2) 10^{-9} mm – 9×10^{-6} mm
 (3) 10^{-3} mm – 10^{-6} mm (4) 10^{-6} mm – 9×10^{-6} mm
 (5) 10^{-7} mm – 10^{-6} mm
13. Which of the following statement is most appropriate to the nanotechnology?
- (1) It is a technology related to static electricity.
 (2) It can be named as a green technology.
 (3) It is a branch of robotic technology.
 (4) Lotus effect can be described using nanotechnology.
 (5) It can be named as a new automobile technology.

14. Following diagrams show circuits with silicon diodes.

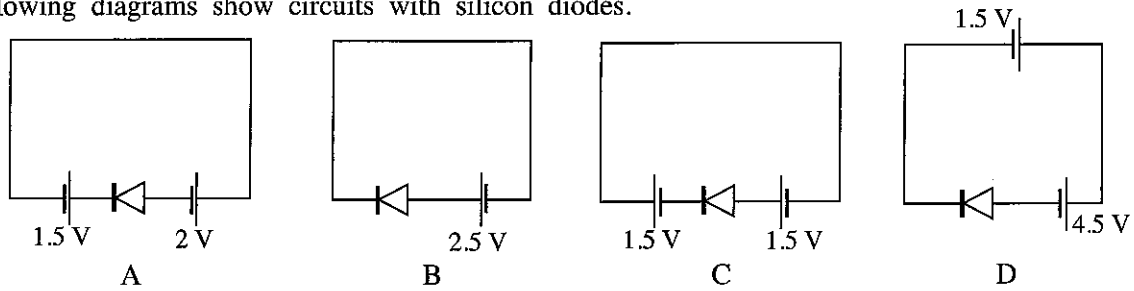

Which of the above circuits are forward biased?

- (1) A and B only.
- (2) B and C only.
- (3) C and D only.
- (4) A and D only.
- (5) A, C and D only.

15. What is the symbol used for a logic gate with an output logic state equals to 1, when only logic state of all inputs are equal to 0?

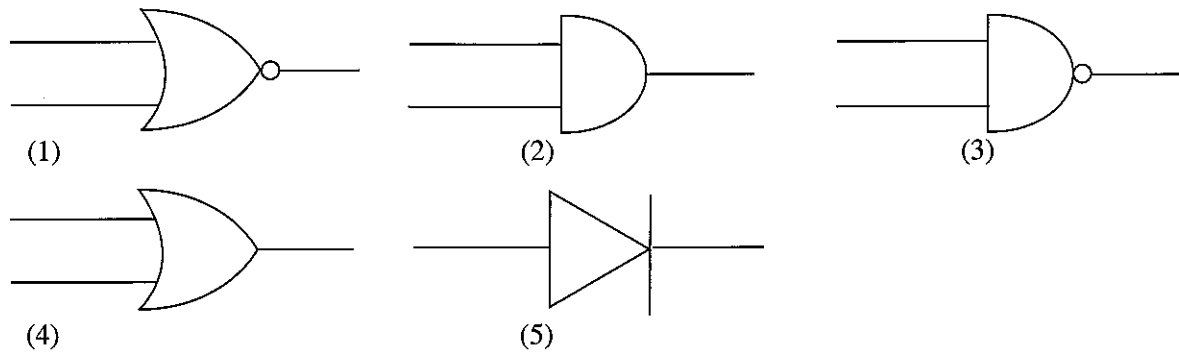

16. Which of the following resistor arrangements has the highest resistance between A and B?

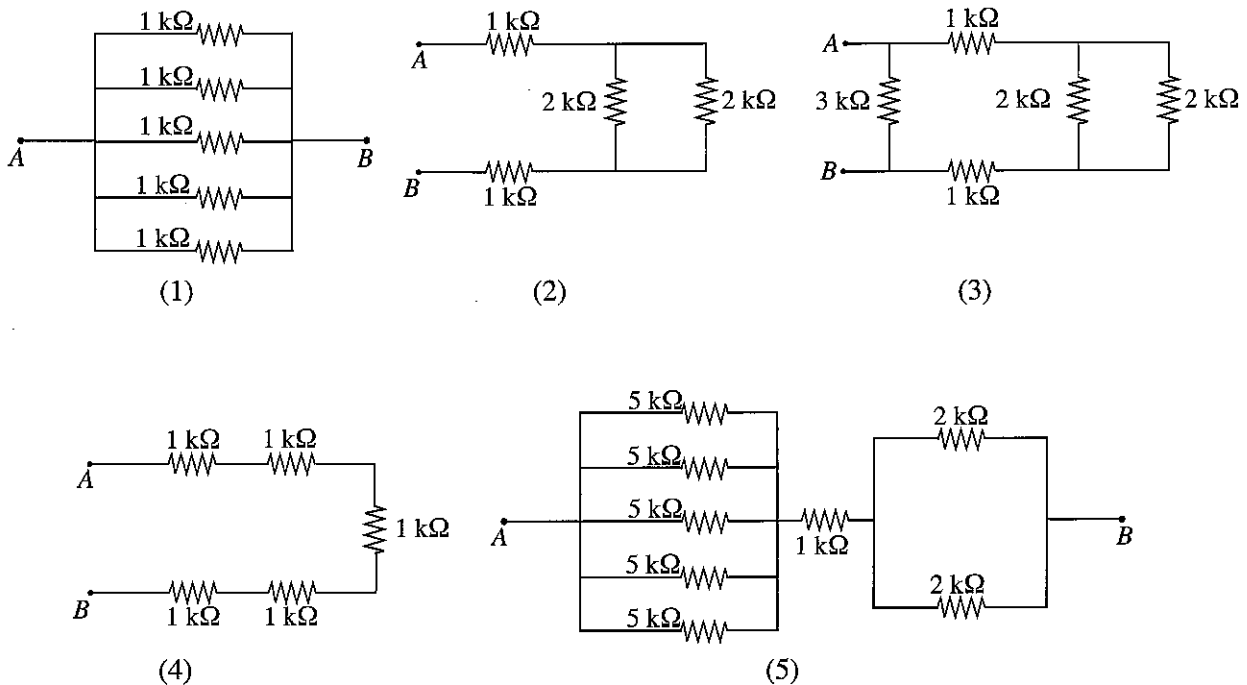

17. Consider the following circuit arrangements.

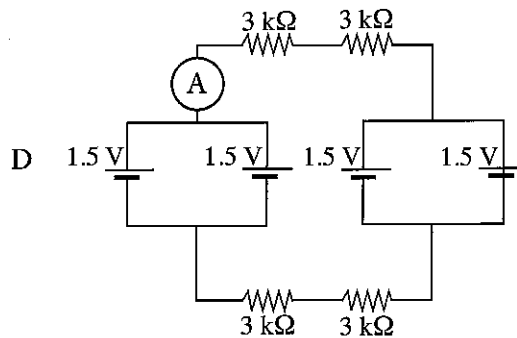
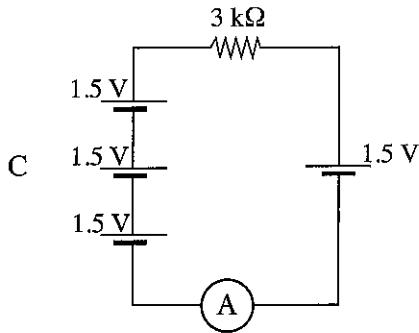
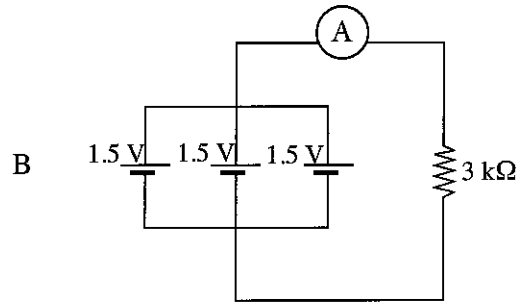
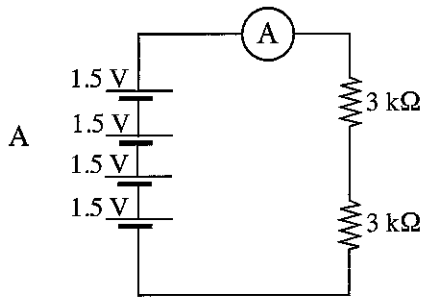

What is the option that gives the ascending order of ammeter readings?

- (1) A, B, C, D (2) A, B, D, C (3) D, B, A, C
 (4) D, C, A, B (5) D, C, B, A

18. A 10W LED lamp is installed in a house wiring circuit. It is switched 2 hours in the morning and for 6 hours at night. What is the daily power consumption of the lamp?

- (1) 0.08 kWh (2) 0.1 kWh (3) 0.8 kWh (4) 10 kWh (5) 80 kWh

19. Select the answer with the component which is **not** used in house wiring circuit?

- (1) Residual current circuit breaker (RCCB), Miniature current circuit breaker (MCCB), Socket outlet.
 (2) Earth electrode, RCCB, MCCB.
 (3) Oscilloscope, earth electrode, RCCB.
 (4) Electricity meter, earth electrode, RCCB.
 (5) Main switch, RCCB, MCCB.

20. Consider the following electronic components.

- A - Capacitor B - Resistor
 C - Diode D - NPN transistor
 E - PNP transistor F - Light Emitting Diode (LED)

Select the option which gives the correct symbols for electronic components given above.

- (1) , , , , ,
- (2) , , , , ,
- (3) , , , , ,
- (4) , , , , ,
- (5) , , , , ,

21. Select the correct view of the given Isometric view when looking from direction A.

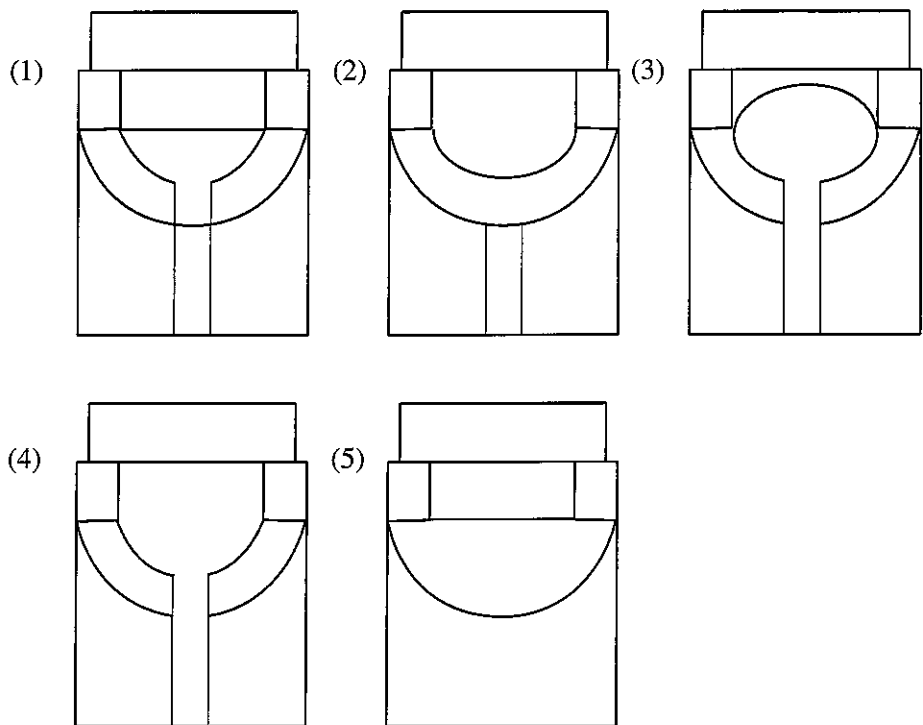
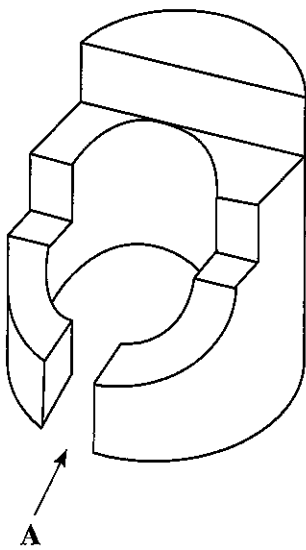

22. A motorcycle accelerates constantly from the rest for 10 seconds and maintains a constant velocity for another 10 seconds. Due to a pedestrian crossing the road, the rider applies sudden brakes to slow down and keeps moving in a lower velocity than before. Which velocity-time graph represents this motion correctly?

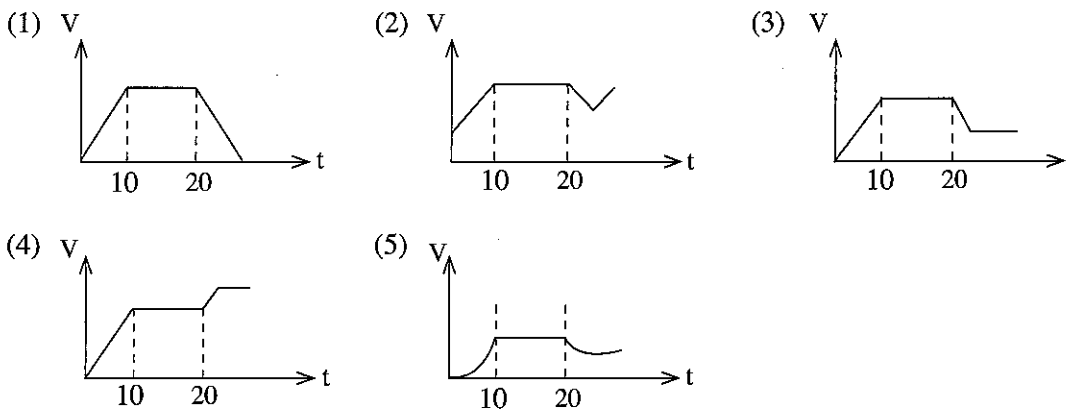

23. As shown in the figure gymnast usually takes a long pole when he walks on a rope at heights. What is the best explanation for this?

- (1) To use the pole to touch the floor in case he tilts.
- (2) To establish the balance by wide spreading the weight of the person and pole.
- (3) To entertain the crowd more as it is difficult to walk with the pole.
- (4) To change the moment of inertia to re-establish the balance using the pole in case of out of balance situations.
- (5) To increase the reaction force from the rope.

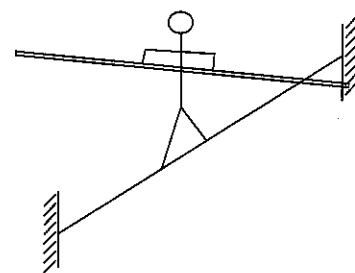

29. Select the correct combinational logic circuit for the Boolean logic expression, $Q = \bar{A}C + B\bar{C}$.

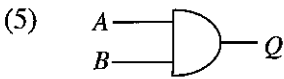
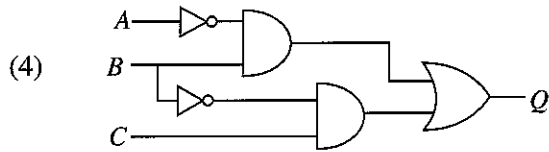
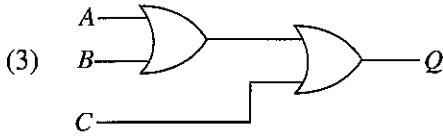
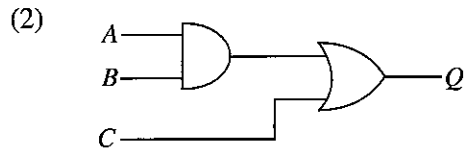
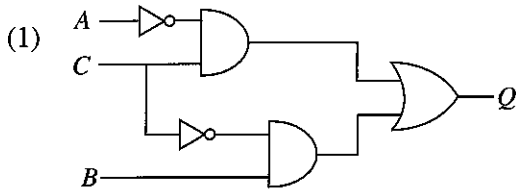

30. Select the triangular waveform which is having a 0V average value.

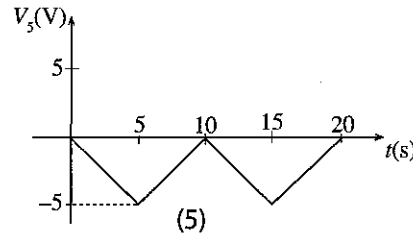
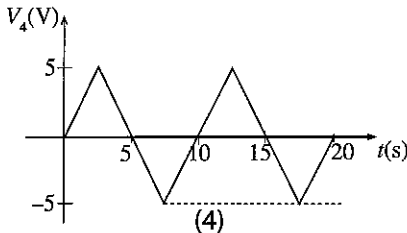
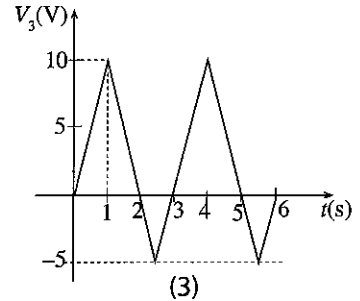
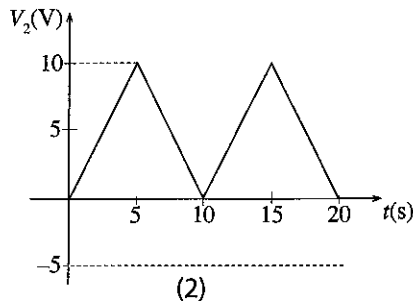
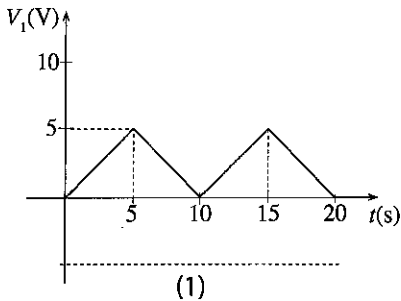

31. Consider following circuits A and B, which connect an ideal capacitor and an ideal inductor to AC supply with frequency f .

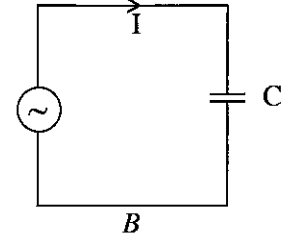
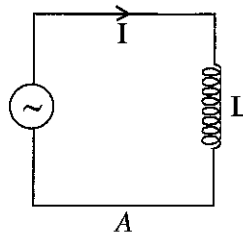

Select the answer with correct phaser representation for A and B.

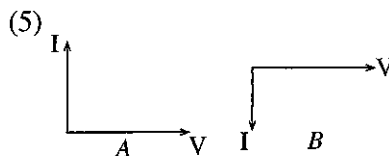
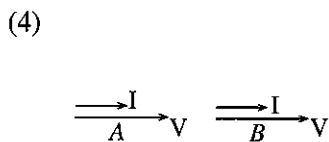
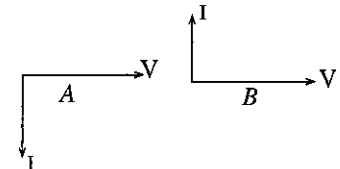
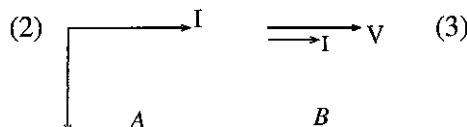
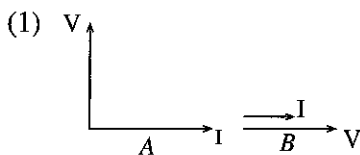

32. The figure shows sinusoidal signal which is observed by an oscilloscope. Voltage magnitude scale and time scale settings of the oscilloscope are 10V/div and 2ms/div respectively. Select the answer that shows the period and frequency of the sinusoidal signal respectively.

- (1) 20 ms, 50 Hz
- (2) 10 ms, 100 Hz
- (3) 10 ms, 50 Hz
- (4) 40 ms, 50 Hz
- (5) 20 ms, 20 Hz

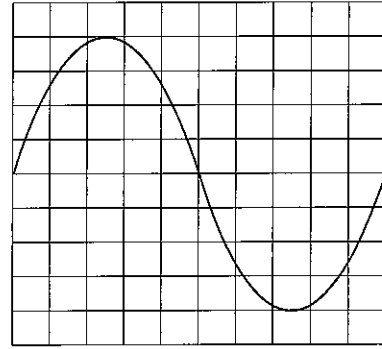

33. Following figure shows how three voltmeters and three ammeters are connected to measure voltage and current across each branch. Assume that all meters are ideal.

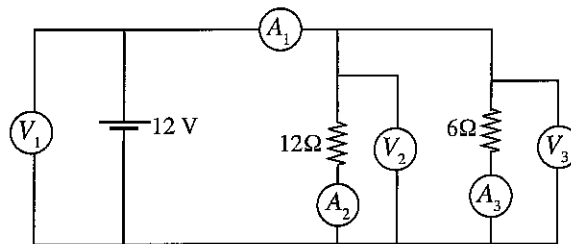

- A - V_1, V_2, V_3 voltmeters and A_1, A_2, A_3 ammeters are connected properly.
 B - Readings of all voltmeters are equal.
 C - Sum of A_2 and A_3 ammeter readings are equal to reading of A_1 .

Select the answer with correct statement/s.

- (1) A only
- (2) B only
- (3) A and B only
- (4) B and C only
- (5) all A, B, and C

34. Consider the following circuit with a resistor network.

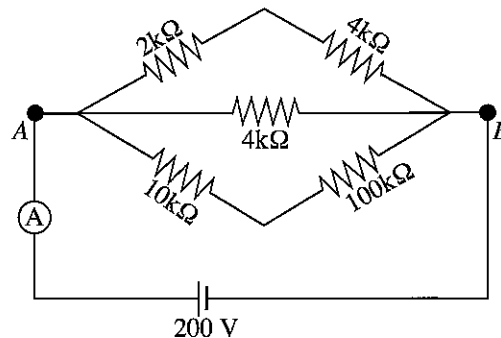

Due to a fault, $100\text{ k}\Omega$ resistor was damaged and open circuited across it. Furthermore, $2\text{ k}\Omega$ resistor was also damaged and short-circuited across it. What is the total current measured in the ammeter after the faults?

- (1) 100 mA
- (2) 10 mA
- (3) 1 mA
- (4) 0.1 mA
- (5) 0 mA

35. An inductive load is connected to an AC supply of V and load consumes I current at a power factor of $\cos \theta$. Active power (P) and reactive power (Q) consumption of the load are given by

- (1) $P = VI, Q = VI$
- (2) $P = VI \cos \theta, Q = VI$
- (3) $P = VI \cos \theta, Q = VI \sin \theta$
- (4) $P = VI, Q = VI \sin \theta$
- (5) $P = VI \cos \theta, Q = 0$

36. Consider following statements.

- A - Documents, pictures can be easily sent by using email facilities such as Gmail, hotmail and yahoo.
 B - Online data storage and online documents can be used for preparing a document by a group of people.
 C - A specific user account and password should be used for login to any webpage.

Select the correct answer with statement/s regarding the use of information technology.

- (1) A only (2) B only (3) A and B only
 (4) A and C only (5) A, B, and C all

37. A logic circuit is shown below.

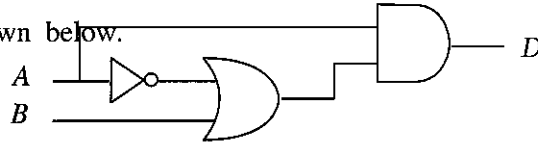

Select the correct output for D.

- (1) $D = A\bar{A} + \bar{B}$ (2) $D = A + \bar{A} + B$ (3) $D = A + \bar{A}B$
 (4) $D = AB$ (5) $D = A\bar{A} + A$
38. A 100W incandescent bulb is going to be replaced by a 20W CFL bulb. The bulb is switched ON 4 hours a day and cost of 1kWh is Rs. 10/=. What is the monthly saving from the replacement? (1 month = 30 days)
- (1) Rs. 120 (2) Rs. 100 (3) Rs. 96 (4) Rs. 36 (5) Rs. 24
39. A 2kW, 230V, 50Hz electronic iron is connected to a domestic electric supply in Sri Lanka. Suddenly the supply voltage dropped to 200V. What is the correct statement regarding the above situation?
- (1) Supply frequency will increase. (2) Power output will decrease.
 (3) Supply current will increase. (4) Reactive power output will increase.
 (5) All of the above.
40. Select the components that are required to identify an earth leakage in a house wiring.
- (1) RCCB, MCCB (2) RCCB, Socket Outlet
 (3) MCCB, earth electrode (4) RCCB, earth electrode
 (5) RCCB, MCCB, earth electrode.

41. A multimeter with small internal resistance is used to measure the current in the following circuit.

Select the correct statement for this measurement.

- (1) Multimeter should be connected parallel to the resistor.
 (2) Current reading is higher than 1A.
 (3) Voltage drop across the resistor is less than 15V.
 (4) The supply current is increased after connecting the meter.
 (5) All of the above.

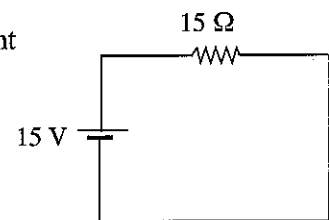

42. A step-up transformer refers to one in which
- (1) the voltage across the secondary is higher than the primary.
 (2) the current in the secondary is higher than the primary.
 (3) the power to the load is higher than delivered to the primary.
 (4) the power to the load is depending on the primary current.
 (5) all of the above.
43. 25W Electric equipment is designed to use with 10V supply. It is going to be connected to a 5V supply. What is the resistance that should be connected with the electrical equipment to limit the current to the rated?
- (1) 0.5 Ω (2) 1 Ω (3) 2 Ω (4) 3 Ω (5) 4 Ω

44. Select the correct statement regarding the power transmission and distribution in Sri Lanka.

- (1) Supply frequency is 60 Hz.
- (2) Transmission line voltage is 132 kV in all areas.
- (3) Distribution line voltage is 11 kV in Lanka Electricity Company (LECO) areas.
- (4) Isolators are used to protect the power network.
- (5) Distribution voltage is higher than the transmission voltage.

45. Following circuit shows an operational amplifier used as an adder. What is the answer with correct output voltage (V_{out}) if $R_f = R_1 = R_2 = R_3$?

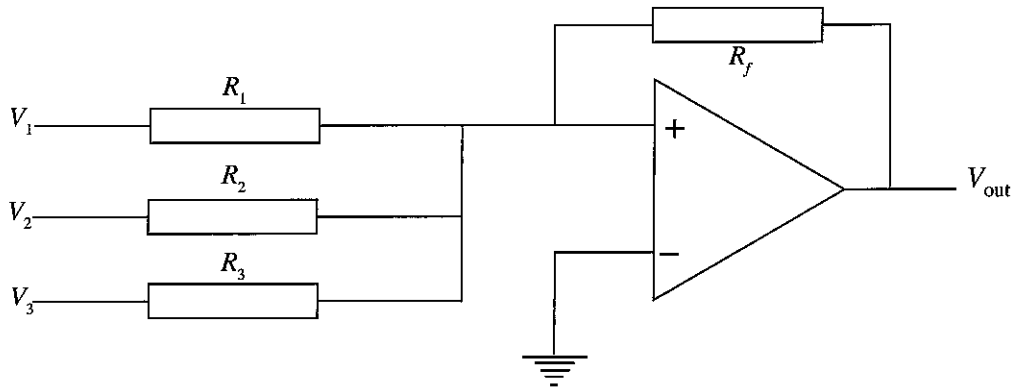

- (1) $+(V_1 + V_2 + V_3)$
- (2) $+\left(\frac{1}{V_1} + \frac{1}{V_2} + \frac{1}{V_3}\right)$
- (3) $-\left(\frac{1}{V_1} + \frac{1}{V_2} + \frac{1}{V_3}\right)$
- (4) $-(V_1 + V_2 + V_3)$
- (5) $-V_1 \cdot V_2 \cdot V_3$

46. NPN transistor in common emitter configuration is operating within active region. Current gain (h_{fe}) when base current $I_B = 0.25$ mA and emitter current $I_E = 50.25$ mA is

- (1) 10.
- (2) 20.
- (3) 100.
- (4) 200.
- (5) 400.

47. What are the correct statement/s regarding the currents in the following circuit? Here $R_1 < R_2 < R_3$.

- A : $I = I_1 + I_2 + I_3$
 B : $I = I_4$
 C : $I = I_1 = I_2 = I_3 = I_4$
 D : $I_1 < I_2 < I_3 < I_4$

- (1) A only
- (2) B only
- (3) A and B only
- (4) A and C only
- (5) A and D only

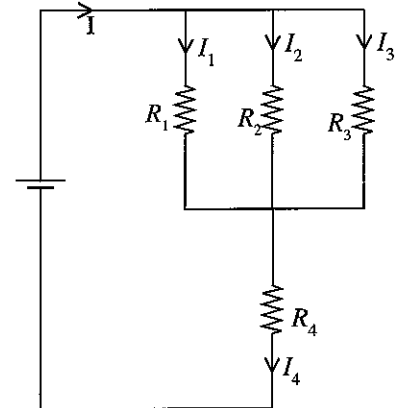

- Answer questions 48, 49 and 50 based on the following production process.

Consider a conveyor system used in a production process of a bottled drink. This conveyor is operated at constant speed by a DC motor (M).

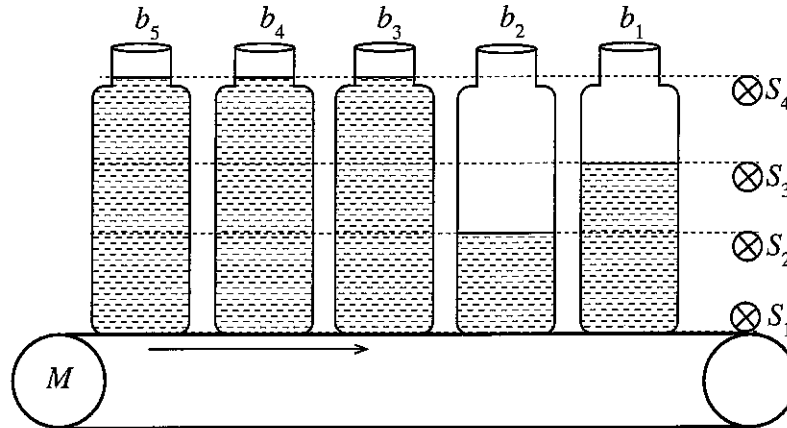

48. Assume that sensor output status will be logic '1', when sensor is covered by the bottle space filled with drink. However sensor output is '0' when sensor is only covered by empty bottle space or sensor is not covered. Find the answer with correct output of sensors S_1 , S_2 , S_3 and S_4 when b_1 , b_2 , b_3 , b_4 and b_5 bottles are passing the sensor array.

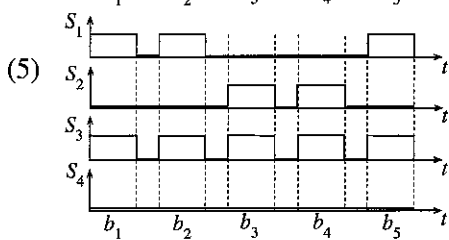
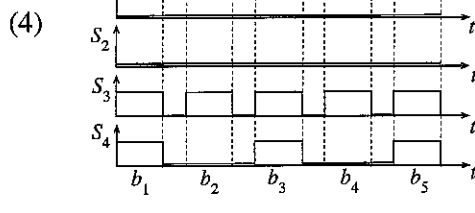
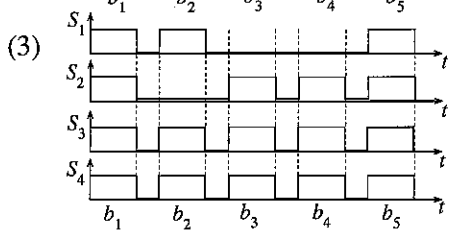
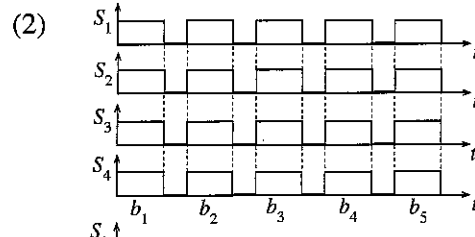
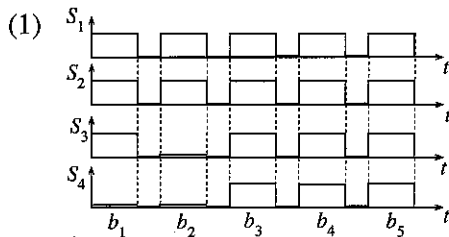

49. Consider following outputs of S_1, S_2, S_3 and S_4 sensors during another sequence of n bottled drinks (not the b_1, b_2, b_3, b_4 and b_5 sequence in figure). Find the answer with properly filled (fully) (n_1) partially filled (n_2), empty number of bottles (n_3) included in this 10 bottles.

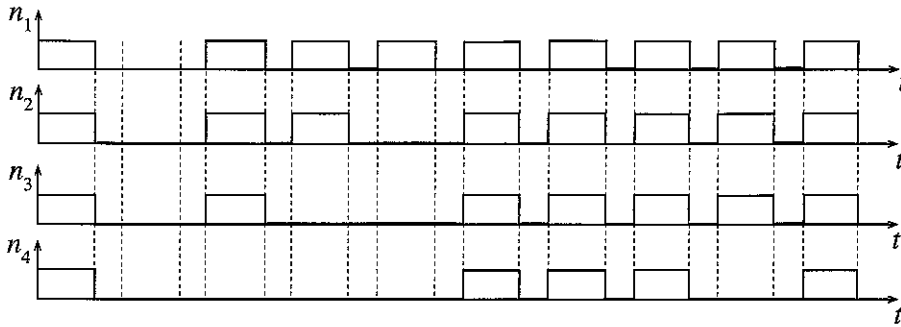

- (1) $n_1 = 5, n_2 = 4, n_3 = 1$
- (2) $n_1 = 4, n_2 = 4, n_3 = 2$
- (3) $n_1 = 1, n_2 = 4, n_3 = 5$
- (4) $n_1 = 1, n_2 = 1, n_3 = 1$
- (5) $n_1 = 10, n_2 = 10, n_3 = 10$

50. Consider the following logic circuits that are prepared for detecting amount of filling when logic output F is 1.

Select the answer with proper usage.

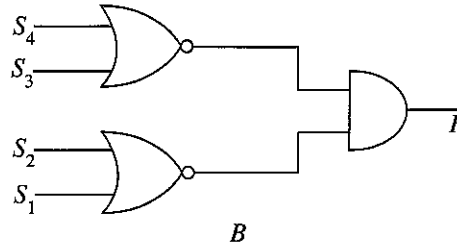
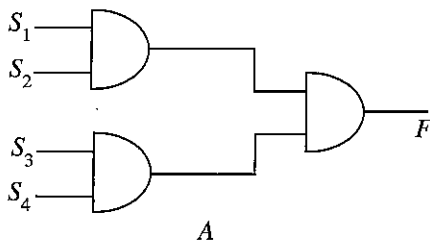

- (1) A - detecting empty bottles, B - detecting properly filled bottles
- (2) A - detecting properly filled bottles, B - detecting empty bottles
- (3) A - detecting properly filled bottles, B - detecting partially filled bottles
- (4) A - detecting partially filled bottles, B - detecting empty bottles
- (5) A - detecting empty bottles, B - detecting empty bottles

ශ්‍රී ලංකා විභාග දෙපාර්තමේන්තුව ශ්‍රී ලංකා විභාග දෙපාර්තමේන්තුව ශ්‍රී ලංකා විභාග දෙපාර්තමේන්තුව ශ්‍රී ලංකා විභාග දෙපාර්තමේන්තුව ශ්‍රී ලංකා විභාග දෙපාර්තමේන්තුව
 இலங்கைப் பரீட்சைத் திணைக்களம் இலங்கைப் பரීட்சைத் திணைக்களம் இலங்கைப் பரීட்சைத் திணைக்களம் இலங்கைப் பரීட்சைத் திணைக்களம் இலங்கைப் பரීட்சைத் திணைக்களம்
 Department of Examinations, Sri Lanka Department of Examinations, Sri Lanka Department of Examinations, Sri Lanka Department of Examinations, Sri Lanka Department of Examinations, Sri Lanka
 இலங்கைப் பரීட்சைத் திணைக்களம் இலங்கைப் பரීட்சைத் திணைக்களம் இலங்கைப் பரīட்சைத் திணைக்களம் இலங்கைப் பரīட்சைத் திணைக்களம் இலங்கைப் பரīட்சைத் திணைக்களம்
 Department of Examinations, Sri Lanka

අධ්‍යයන පොදු සහතික පත්‍ර (උසස් පෙළ) විභාගය, 2018 අගෝස්තු
கல்விப் பொதுத் தராதரப் பத்திர (உயர் தர)ப் பரீட்சை, 2018 ஆகஸ்ட்
General Certificate of Education (Adv. Level) Examination, August 2018

විදුලිය, ඉලෙක්ට්‍රොනික හා තොරතුරු තාක්ෂණවේදය II
 மின், இலத்திரன் தகவல் தொழினுட்பவியல் II
Electrical, Electronic and Information Technology II

16 E II

16.08.2018 / 13 00 - 16 10

පැය තුනයි
 மூன்று மணித்தியாலம்
Three hours

අමතර කියවීමේ කාලය - මිනිත්තු 10 යි
 மேலதிக வாசிப்பு நேரம் - 10 நிமிடங்கள்
Additional Reading Time - 10 minutes

Use **additional reading time** to go through the question paper, select the questions and decide on the questions that you give priority in answering.

Index No. :

Important :

- * This question paper consists of 12 pages.
- * This question paper comprises **Parts A, B and C**. The time allotted for **all parts** is **three hours**. (Use of calculators is **not** allowed.)

Part A - Structured Essay (08 pages)

- * Answer **all** the questions on this paper itself.
- * Write your answers in the space provided for each question. Note that the space provided is sufficient for your answers and that extensive answers are not expected.

Part B and C - Essay (04 pages)

- * Select minimum of **two** questions from each of the parts **B and C** and answer **four** questions only. Use the papers supplied for this purpose. At the end of the time allotted for this paper, tie the **three parts** together so that **Part A** is on the top of **Part B and C** before handing over to the supervisor.
- * You are permitted to remove only **Parts B and C** of the question paper from the Examination Hall.

For Examiner's Use Only

Part	Q. No.	Marks
A	1	
	2	
	3	
	4	
B	1	
	2	
	3	
C	4	
	5	
	6	
Total		
Percentage		

Final Marks

In Numbers	
In Words	

Code Numbers

Marking Examiner 1	
Marking Examiner 2	
Checked by	
Supervised by	

PART A – Structured Essay
 Answer *all four* questions on this *paper itself*.
 (Each question carries 10 marks)

Do not write in this column

1. An isometric view of a machine component is shown in the figure. Machine component is symmetric along the vertical plane passing through X-X. Assuming any missing dimensions, draw the following views to a suitable scale using first angle projection principle. Show all relevant dimensions in the sketches. Use the graph sheets given on page 3 and 4 to answer the questions. (All dimensions are in mm.)

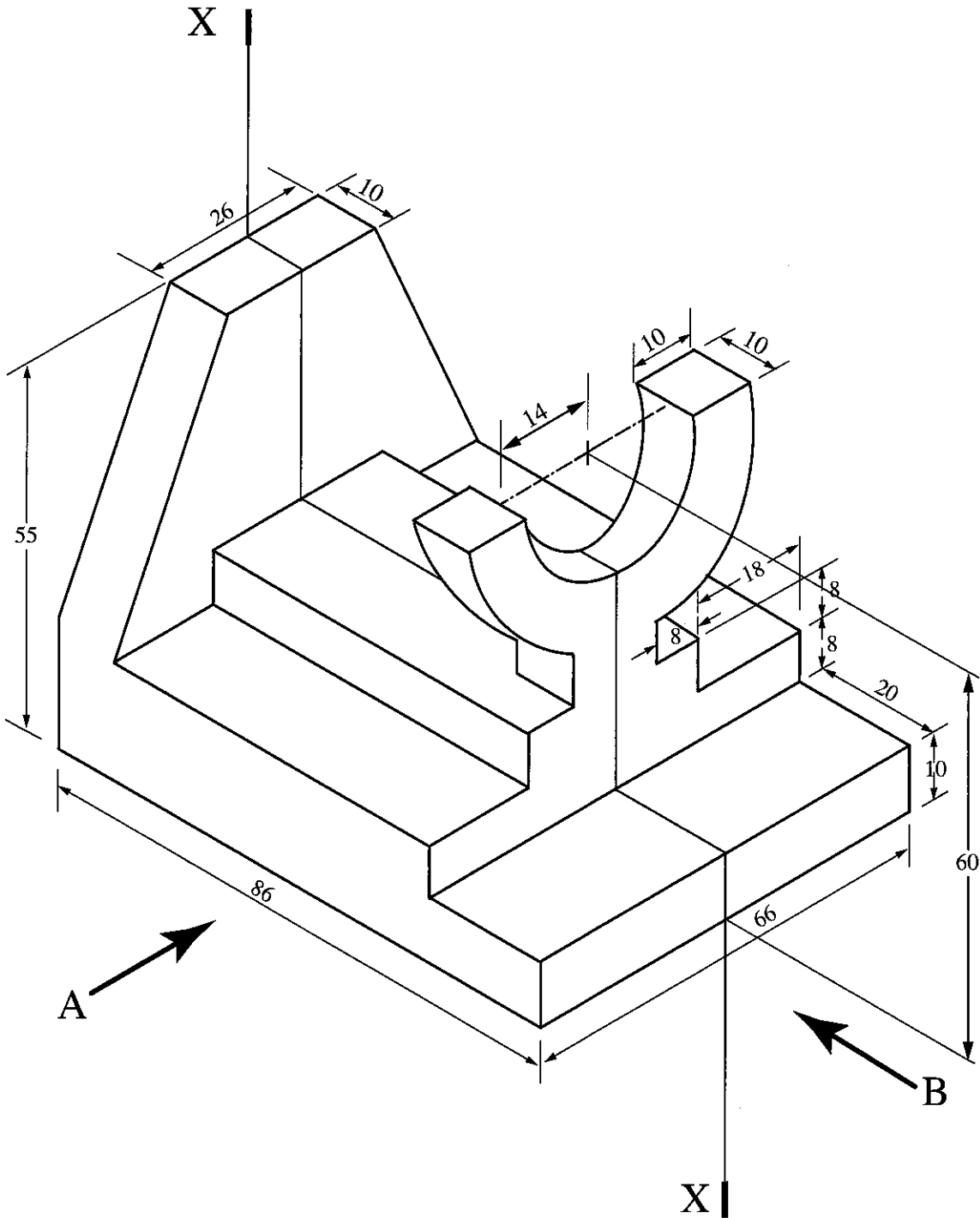

- (i) Front elevation seen through direction A.
- (ii) End elevation seen through direction B.
- (iii) Plan view.



Index No. :

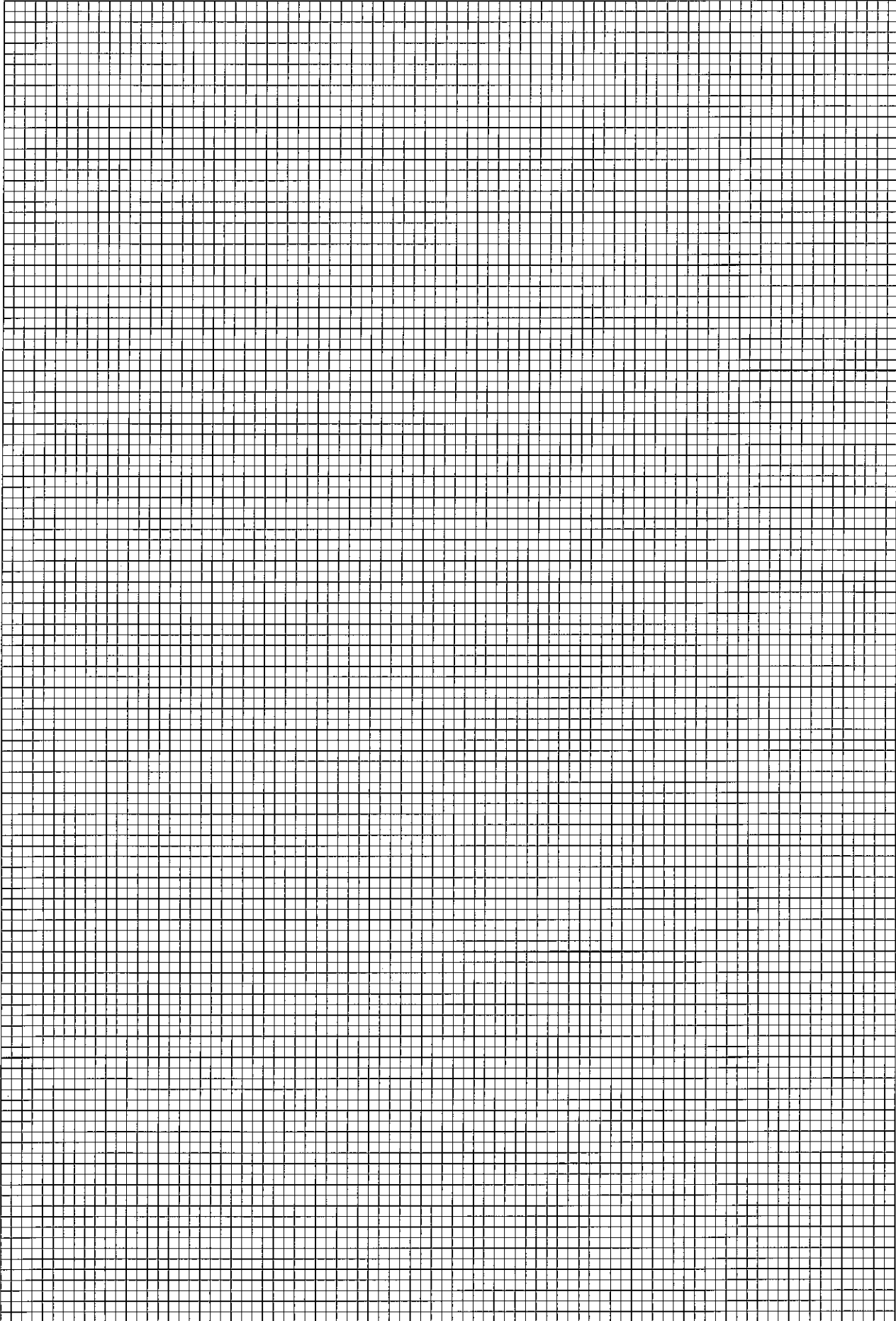

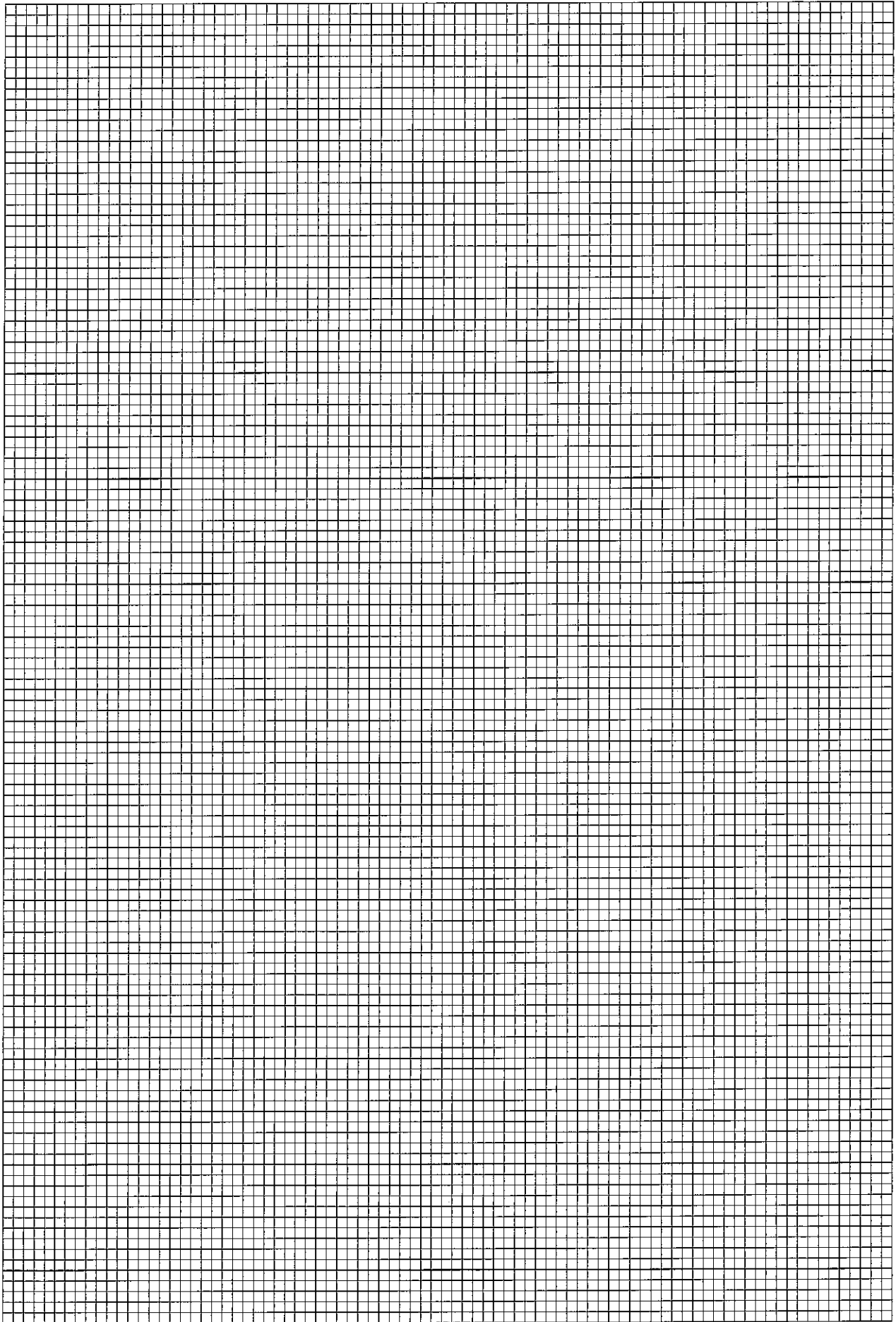

Do not write in this column

2. Assume that you have been appointed as the IT technical officer responsible for improving IT facilities of a school. Answer the following questions related to IT facilities.

(a) School has decided to establish a computer laboratory with 25 desktop computers. This laboratory will be used as a common facility for all students. The laboratory should include facilities for preparing documents, presentations and searching information in the Internet.

(i) State **four** hardware units required for a fully functional computer.

- (1)
- (2)
- (3)
- (4)

(ii) Give **two** software required for the computer units.

- (1)
- (2)

(iii) State **one** facility required for the computers.

.....

(b) It has been decided to improve the computer laboratory to facilitate programs conducted by teachers for other schools in remote areas through video conferencing.

(i) Name **two** additional hardware required for the computer laboratory in addition to the fully functional computers.

.....
.....
.....

(ii) State **one** software package required to carry out video conferencing.

.....
.....

(c) Assume that a project is being conducted by a group of 10 students under the supervision of a teacher from a school in a remote area, students are working in computer laboratory of the school and the teacher is at another school. Furthermore, assume that relevant hardware and internet facilities are available for the teacher and the students. State required software facilities for simultaneously preparing a report by 10 students and as the teacher can comment while preparing the report.

.....
.....
.....
.....
.....



Do not write in this column

3. Consider following circuit which connects a DC source, two resistors and a bulb, and answer the questions.

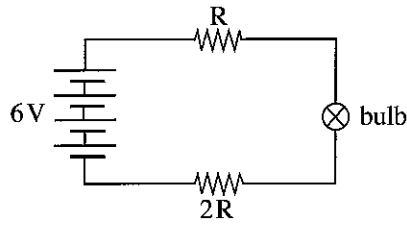

Figure 03

(a) List the measuring equipments required for measuring voltages across R, 2R resistors, bulb, supply voltage and circuit current.

.....

.....

.....

.....

.....

.....

(b) Draw the circuit and indicate how the selected measuring equipment can be connected.

(c) Draw the circuit and indicate how a switch can be inserted to control (ON/OFF) the bulb.

Do not write in this column

(d) It has been decided to modify the circuit to reduce the current to half of the previous value by adding more R resistors. (Assume that any number of R resistors are available). Sketch a suitable arrangement of the modified circuit.

(e) Further initial circuit (in figure 03) is modified to double the circuit current by adding additional R resistors. (Assume that any number of R resistors are available.) Sketch a suitable arrangement of the modified circuit.



4. (a) (i) List factors affecting the synchronous speed of an induction motor.

.....
.....
.....
.....
.....
.....

(ii) Assume a single phase induction motor with four starting and four running windings in the stator. Calculate the synchronous speed when it is connected to a 230V, 50Hz AC supply.

.....
.....
.....
.....
.....

Do not write in this column

(b) State the meaning of each item in the following specification table (name plate) of an induction motor.

Induction Motor			
.....	: 3 ϕ	: 0.7 kW
.....	: 2 A	: 1420 RPM
.....	: 400 V	: Δ
.....	: 50 Hz		

(c) There are different types of DC motors based on how armature winding and field winding are connected. Sketch diagrams and indicate how field and armature windings are connected in the following DC motors.

(i) DC series motor

(ii) DC shunt motor

(iii) DC Compound motor

(iv) Separately excited DC motor



සියලු ම හිමිකම් ඇවිරිණි / முழுப் பதிப்புரிமையுடையது / All Rights Reserved

ශ්‍රී ලංකා විභාග දෙපාර්තමේන්තුව ශ්‍රී ලංකා විභාග දෙපාර්තමේන්තුව ශ්‍රී ලංකා විභාග දෙපාර්තමේන්තුව ශ්‍රී ලංකා විභාග දෙපාර්තමේන්තුව ශ්‍රී ලංකා විභාග දෙපාර්තමේන්තුව
 இலங்கைப் பரீட்சைத் திணைக்களம் இலங்கைப் பரීட்சைத் திணைக்களம் இலங்கைப் பரීட்சைத் திணைக்களம் இலங்கைப் பரීட்சைத் திணைக்களம் இலங்கைப் பரීட்சைத் திணைக்களம்
 Department of Examinations, Sri Lanka Department of Examinations, Sri Lanka Department of Examinations, Sri Lanka Department of Examinations, Sri Lanka Department of Examinations, Sri Lanka
 இலங்கைப் பரීட்சைத் திணைக்களம் இலங்கைப் பரීட்சைத் திணைக்களம் இலங்கைப் பரීட்சைத் திணைக்களம் இலங்கைப் பரීட்சைத் திணைக்களம் இலங்கைப் பரීட்சைத் திணைக்களம்
 Department of Examinations, Sri Lanka Department of Examinations, Sri Lanka Department of Examinations, Sri Lanka Department of Examinations, Sri Lanka Department of Examinations, Sri Lanka

අධ්‍යයන පොදු සහතික පත්‍ර (උසස් පෙළ) විභාගය, 2018 අගෝස්තු
 கல்விப் பொதுத் தராதரப் பத்திர (உயர் தர)ப் பரீட்சை, 2018 ஓகஸ்ட்
 General Certificate of Education (Adv. Level) Examination, August 2018

විදුලිය, ඉලෙක්ට්‍රොනික හා තොරතුරු තාක්ෂණවේදය II
 மின், இலத்திரன் தகவல் தொழினுட்பவியல் II
 Electrical, Electronic and Information Technology II

16 E II

Essay

* Select two questions from each of the Parts B and C and answer four questions only.
 (Each question carries 15 marks.)

Part B

1. The dengue fever has become an epidemic in Sri Lanka during the past few years. The fever is spreading rapidly, specially in slum areas. This situation has posed many challenges for controlling the spread of disease, in inter and intra regional communities.

(a) In order to curb this epidemic, following actions could be taken.

- ① To control breeding of mosquito carrying the virus
- ② To keep away the mosquito carrying the virus
- ③ To prevent spreading virus to inter regions

Briefly explain two suitable technological measures you could take with regard to

- (i) above ① at the school.
- (ii) above ② at your home.
- (iii) above ③.

(b) You are appointed to educate the people in slum areas to control the epidemic within their own community. Briefly explain how you could use technology to make people aware to control this.

2. A smart building is a new concept in the today's world with prime objectives such as saving energy and contributing to achieve the sustainability goals. In order to achieve sustainability goals the design of the electrical system is very important. Assuming that you are the technical officer in a smart building project, answer the following questions. Main electricity consuming equipments in the building are identified as below.

Equipment	Power	Quantity	Average daily usage (hours)
Bulbs	20 W	5	7
	100 W	2	2
Air Condition	4 kW	1	6
Refrigerator	100 W	1	15
Others	200 W	1	5

- (a) What is the total daily electricity consumption in kWh?
- (b) Calculate the maximum possible current taken by the building assuming 240 V supply voltage?
- (c) A single phase transformer is used to supply the above current. What is the minimum capacity of the transformer needed in kW?

(d) In order to convert the building into a sustainable building the owner is suggested to use solar energy from a roof-top 1kW photovoltaic (PV) plant. It will generate energy for 4 hours per day. The generated electricity will be sold to Ceylon Electricity Board (CEB) with the rate of Rs.20 per kWh. Calculate the total income per month of 30 days from solar energy.

(e) Details of 1kW PV plant is given below.

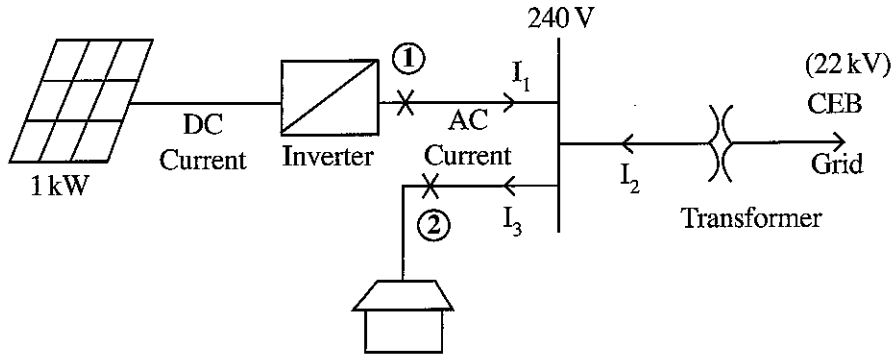

(i) Find the maximum possible AC current generating from the PV plant.

(ii) Find the suitable rating of the fuses at point ① and ② .

3. A rural household receives pipe borne potable quality water, under gravity, from a community water supply scheme. It delivers water at daily, an average rate of 2 litres per minute, for a period of 5 hours, from 10 p.m. to 3 p.m.

The household has two adults, and three children of school going age and water is used for drinking, cooking, washing clothes, sanitary requirements and for home gardening.

(a) Estimate the daily household water requirement for each purpose listed above, stating the assumptions you have made.

(b) Show on a sketch the layout of the water storage and distribution system for this dwelling. Name the components of the system while stating their specific use.

(c) Suppose that the household wishes to collect rain water to enhance its water needs. Propose how you would integrate the rain water collection system, to meet the domestic water needs. Use of sketches is expected to convey the proposal.

Part C

4. (a) Answer the following questions based on the combinational logic circuit given in the following figure.

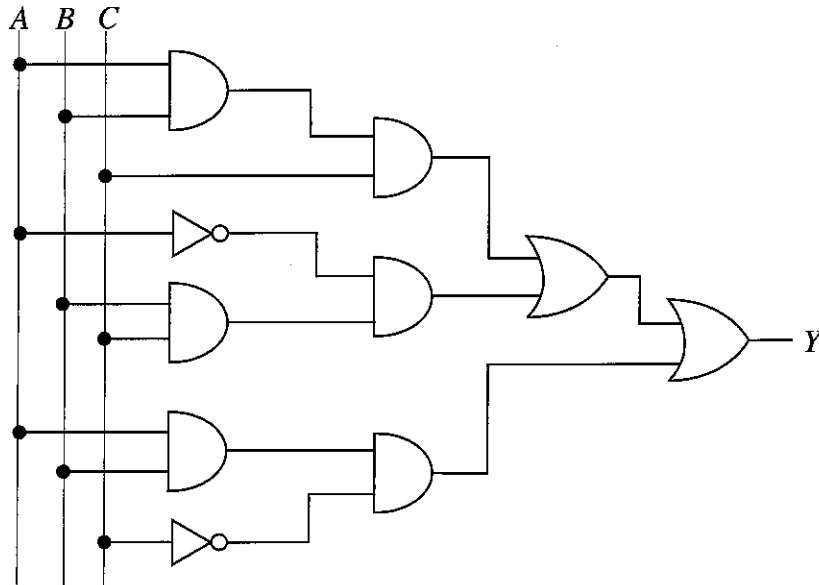

- (i) Write the Boolean expression for the logic circuit output Y .
- (ii) Simplify the above to obtain the most simplified Boolean expression.
- (iii) Write the truth table for the simplified Boolean expression.
- (iv) Draw the logic circuit for the simplified Boolean expression.

(b) Consider the following flipflop circuit and answer the questions.

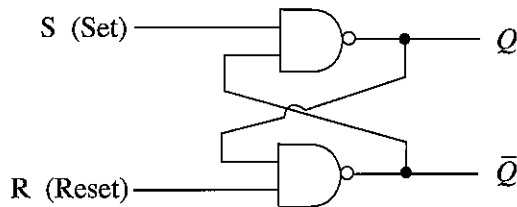

- (i) Write the truth table for the Set-Reset function of the SR flipflop.
- (ii) Obtain the output Q and \bar{Q} for the following Set-Reset sequence.

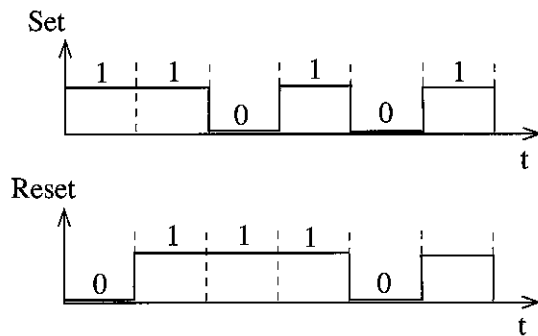

5. Assume that you have been asked to develop a new website using HTML for the new science laboratory of the school. Front page of the website is to be developed as given here. There is a plan to develop separate web pages accessible from the front page for 'About', 'Facilities' and 'Student Activities'.

- (a) Write the program with HTML tags to develop the above front page.
 (b) Laboratory equipment such as meters, oscilloscopes, basic electrical and electronic items have been already purchased.

Write HTML program to develop a separate web page for the facilities including details and images.

- (c) Students are planning to have an electronics design competition for students.
 (i) Write HTML program for preparing a separate web page for student activities.
 (ii) An application for the competition has already been prepared by using an online form. Modify the HTML in part (i) to add a link for the application in the bottom of the web page.

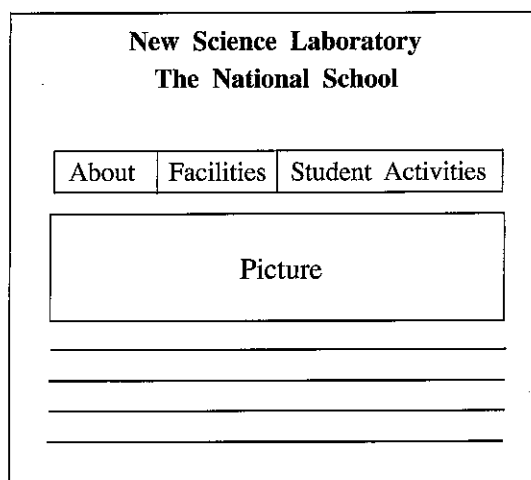

6. Passive electrical components such as inductors and capacitors can be used to control AC.

(a) Following figure 6.(a) shows an experimental set-up developed to study the effects of inductors when connected to AC.

- (i) Write an expression for inductive reactance.
 (ii) Calculate the inductive reactance of the inductor when supply AC voltage is 230 V in magnitude and 50 Hz in frequency. Here inductance (L) of the inductor is 10 mH.

V - Supply voltage
 f - Supply frequency

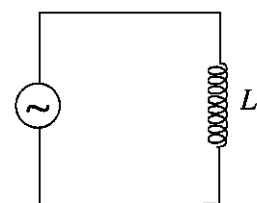

figure 6.(a)

(b) A group of students has replaced the inductor in the circuit of part 6.(a) by a capacitor as given in figure 6.(b).

- (i) Write an expression for capacitive reactance.
 (ii) Calculate the capacitive reactance of the capacitor when supply voltage is 230 V and frequency is 50 Hz. Here capacitance of the capacitor is 1000 μ F.

V - Supply voltage
 f - Supply frequency

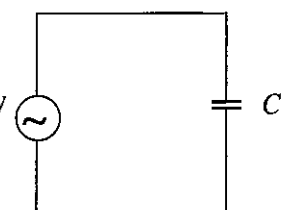

figure 6.(b)

(c) State a method to improve the power factor of load which is in a series connection of resistor (R) and inductor (L).

* * *