

සියලු ම හිමිකම් ඇවිරිණි / முழுப் பதிப்புரிமையுடையது / All Rights Reserved

ශ්‍රී ලංකා විභාග දෙපාර්තමේන්තුව ශ්‍රී ලංකා විභාග දෙපාර්තමේන්තුව ශ්‍රී ලංකා විභාග දෙපාර්තමේන්තුව ශ්‍රී ලංකා විභාග දෙපාර්තමේන්තුව ශ්‍රී ලංකා විභාග දෙපාර්තමේන්තුව
 இலங்கைப் பரீட்சைத் திணைக்களம் இலங்கைப் பரීட்சைத் திணைக்களம் இலங்கைப் பரීட்சைத் திணைக்களம் இலங்கைப் பரීட்சைத் திணைக்களம் இலங்கைப் பரීட்சைத் திணைக்களம்
 Department of Examinations, Sri Lanka Department of Examinations, Sri Lanka Department of Examinations, Sri Lanka Department of Examinations, Sri Lanka Department of Examinations, Sri Lanka
 ශ්‍රී ලංකා විභාග දෙපාර්තමේන්තුව ශ්‍රී ලංකා විභාග දෙපාර්තමේන්තුව ශ්‍රී ලංකා විභාග දෙපාර්තමේන්තුව ශ්‍රී ලංකා විභාග දෙපාර්තමේන්තුව ශ්‍රී ලංකා විභාග දෙපාර්තමේන්තුව
 இலங்கைப் பரීட்சைத் திணைக்களம் இலங்கைப் பரීட்சைத் திணைக்களம் இலங்கைப் பரීட்சைத் திணைக்களம் இலங்கைப் பரීட்சைத் திணைக்களம் இலங்கைப் பரීட்சைத் திணைக்களம்
 Department of Examinations, Sri Lanka Department of Examinations, Sri Lanka Department of Examinations, Sri Lanka Department of Examinations, Sri Lanka Department of Examinations, Sri Lanka

අධ්‍යයන පොදු සහතික පත්‍ර (උසස් පෙළ) විභාගය, 2018 අගෝස්තු
 கல்விப் பொதுத் தராதரப் பத்திர (உயர் தர)ப் பரீட்சை, 2018 - ஆகஸ்ட்
 General Certificate of Education (Adv. Level) Examination, August 2018

15.08.2018 / 0830 - 1030

තාක්ෂණවේදය සඳහා විද්‍යාව I
 தொழினுட்பவியலுக்கான விஞ்ஞானம் I
 Science for Technology I

67 E I

පැය දෙකයි
 இரண்டு மணித்தியாலம்
 Two hours

Instructions:

- * Answer *all* the questions.
- * Write your **Index Number** in the space provided in the answer sheet.
- * Read the instructions given on the back of the answer sheet carefully.
- * In each of the questions 1 to 50, pick one of the alternatives from (1), (2), (3), (4), (5) which is **correct** or **most appropriate** and mark your response on the answer sheet with a cross (x) in accordance with the instructions given on the back of the answer sheet.
- * Use of calculators is not allowed.

1. *Corynebacterium glutamicum* bacteria is used to produce
 (1) antibiotics. (2) ethanol. (3) amino acids. (4) vinegar. (5) beer.
2. Consider the following microorganisms.
 (A) *Streptococcus lactis*
 (B) *Clostridium tetani*
 (C) *Lactobacillus spp.*
 Which of the above microorganism/s is/are used in curd production?
 (1) (A) only. (2) (B) only. (3) (C) only.
 (4) (A) and (B) only. (5) (A) and (C) only.
3. Two monosaccharides present in beetroot are
 (1) glucose and sucrose. (2) glucose and galactose.
 (3) galactose and fructose. (4) glucose and fructose.
 (5) glucose and lactose.
4. Anerobic microbial activity of a wastewater treatment plant is used at the step of,
 (1) primary treatment. (2) secondary treatment. (3) settling tank.
 (4) sludge digestion. (5) disinfection and release.
5. Consider the following statements.
 The reaction between vinegar and sodium hydroxide solution is an
 (A) acid base reaction.
 (B) exothermic reaction.
 (C) endothermic reaction.
 Of the above, the correct statement/s would be
 (1) (A) only. (2) (B) only. (3) (C) only.
 (4) (A) and (B) only. (5) (A) and (C) only.
6. Heat can be defined as the
 (1) temperature of a system. (2) total amount of energy of a system.
 (3) flow of energy between two systems. (4) amount of work done on a system.
 (5) amount of work done by a system.
7. Activation energy for a given reaction is the
 (1) average energy of reactants.
 (2) average energy of reactants at 25 °C and 1 atmospheric pressure.
 (3) energy difference between reactants and products.
 (4) minimum amount of energy required to initiate the reaction.
 (5) amount of energy released from the reaction.

[See page two

8. Consider the following statements.
Vulcanized rubber
(A) has more cross links than natural rubber.
(B) can be softened using heat and remoulded to a new shape.
(C) is stronger than natural rubber.
Of the above, the correct statement/s would be
(1) (A) only. (2) (A) and (B) only. (3) (A) and (C) only.
(4) (B) and (C) only. (5) All (A), (B) and (C).
9. Use of the 4R concept is more suitable than the 3R concept for the plastic recycling process in Sri Lanka. The newly added fourth R concept to the 3R concept is
(1) Reuse. (2) Recycle. (3) Reduce. (4) Rethink. (5) Refuse.
10. All natural products are
(1) produced using water, carbon dioxide and other compounds.
(2) produced only by plants.
(3) primary metabolites only.
(4) useful for the growth of living organisms.
(5) volatile organic compounds.
11. Which of the following can be used to draw the baseline when preparing a thin layer chromatographic plate?
(1) A ball-point pen (2) A sharp object (3) A marker pen
(4) A blunt object (5) A pencil
12. An investor refused to start a caustic soda production plant saying it will not be commercially viable in Sri Lanka. What can be the main reason for the above decision of the investor?
(1) Formation of by-products
(2) High cost of electricity
(3) High production cost of pure NaCl
(4) Pure NaCl is not commercially available.
(5) No market for caustic soda in Sri Lanka
13. Production of TiO_2 nano particles is a suitable industry for Sri Lanka. This is due to the
(1) availability of Ilmenite in Pulmude.
(2) availability of Apatite in Eppawala.
(3) popularity of the production of TiO_2 nano particles in Sri Lanka.
(4) availability of the industries based on TiO_2 nano particles in Sri Lanka.
(5) availability of TiO_2 nano particle deposits in Sri Lanka.
14. Which of the following government institutions is responsible for issuing Sri Lankan Patents?
(1) Sri Lanka Inventors Commission
(2) Ministry of Science, Technology and Research
(3) National Intellectual Property Office
(4) National Science Foundation
(5) Ministry of Higher Education
15. Acid rains are produced due to dissolution of atmospheric acidic gases in atmospheric water. Which of the following statements is true about acid rains?
(1) Carbon dioxide can produce acid rains.
(2) The acidity of an acid rain depends on the amount of acidic gases dissolved.
(3) The acidity of an acid rain is independent of the strength of the acid produced.
(4) Atmospheric SO_2 does not produce acid rains.
(5) The pH value of acid rains is higher than 7.

16. Consider the following statements regarding compost fertilizers.
- (A) The amount of primary nutrients in compost fertilizers is higher than that of chemical fertilizers.
- (B) Compose fertilizers improve the cation exchange capacity of soil.
- (C) Compost fertilizers mainly provide micronutrients to plants.
- Of the above, the correct statement/s would be
- (1) (A) only. (2) (A) and (B) only. (3) (A) and (C) only.
 (4) (B) and (C) only. (5) All (A), (B) and (C).
17. The type of rays requires for the natural generation of ozone gas is,
- (1) infrared rays. (2) X-rays. (3) visible light.
 (4) ultra violet rays. (5) Gamma rays.
18. If 1 litre of paint is required to paint a surface area of 1000 cm^2 , then the volume of paint needed (in litres) to apply on the surface of a closed right circular cone with a slant height 36 cm and base radius 14 cm is, $\left(\pi = \frac{22}{7}\right)$
- (1) 1.584 (2) 2.200 (3) 616 (4) 1584 (5) 2200
19. It is required to construct a staircase to climb 15 m vertically, when 25 m horizontal distance is travelled. How many steps are needed for this purpose when the width and the height of each step are 25 cm and 15 cm, respectively?
- (1) 10 (2) 20 (3) 40 (4) 100 (5) 200
20. Consider a line segment AB , which connects points $A \equiv (1, 2)$ and $B \equiv (5, 4)$. The line which is perpendicular to AB and goes through the mid-point of AB cuts the Y -axis at the point of
- (1) (9, 0) (2) (0, 9) (3) (4.5, 0) (4) (0, 4.5) (5) (0, 1.5)
21. Aerial and cross sectional views of a swimming pool are given below. The volume of water required to fill the pool is,

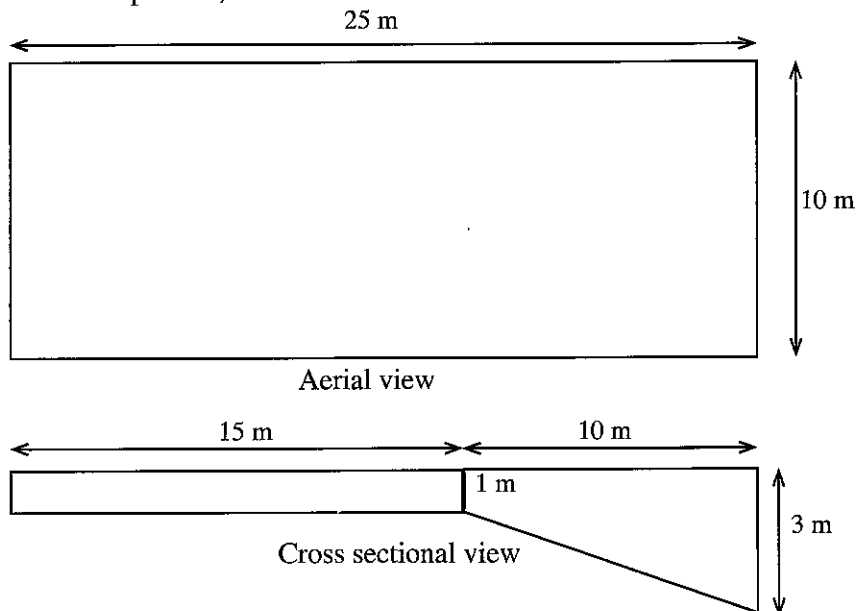

- (1) 15 m^3 . (2) 35 m^3 . (3) 250 m^3 . (4) 350 m^3 . (5) 550 m^3 .
22. The class limits of a grouped frequency distribution is given in the table and its mean is found to be 9. However, it was observed later that the grouped frequency distribution was constructed by incorrectly recording 16 instead of 8. Hence, it was corrected and the mean was recalculated and found to be 7. How many data points are there in the grouped frequency distribution?
- | Class limit |
|-------------|
| 1 - 5 |
| 6 - 10 |
| 11 - 15 |
| 16 - 20 |
- (1) 3 (2) 4
 (3) 5 (4) 8
 (5) Insufficient information to calculate.

23. Consider the following data set.
 $-1, -2, -2, 0, -5, 5, 3, 5, 6, 121, -4, 125$
 The most suitable measure/s of central tendency for the data set is/are,
 (1) mean. (2) median. (3) mode.
 (4) mean and median. (5) median and mode.
24. A company wishes to design a water tank of a given volume. The proposed two shapes are a cylindrical tank with a radius of 3 units and a spherical tank with a radius of 3 units. The production cost per unit surface area for each shape is Rs. 10/-. If $\pi = 3$, the production costs for cylindrical and spherical shaped tanks respectively in rupees are,
 (1) 1260 and 1080. (2) 1080 and 1260. (3) 1260 and 565.
 (4) 1080 and 565. (5) 1260 and 377.
25. The perimeter of the triangle whose vertices are (2, 2), (10, 8) and (10, 17) in linear units is,
 (1) 36 (2) $\sqrt{389}$ (3) $\sqrt{470}$ (4) 389 (5) 470
26. Consider the two lines given by $2x + 3y + 1 = 0$ and $4x + 6y + 1 = 0$. These two lines
 (1) have the same intercept. (2) are perpendicular.
 (3) coincide. (4) are passing through the origin.
 (5) are parallel.
27. The point resides on the both lines $x - 2y = 1$ and $2x - y = 1$ is,
 (1) (1, 0) (2) (0, 1) (3) $\left(\frac{1}{3}, -\frac{1}{3}\right)$ (4) $\left(-\frac{1}{3}, \frac{1}{3}\right)$ (5) (0, 0)
28. Which of the following is **not** an important factor to consider when purchasing a computer?
 (1) Hard disk capacity (2) Random Access Memory (RAM)
 (3) Processor type and speed (4) Printer type
 (5) Number of USB ports
29. Consider the following statements about the memory of a computer.
 (A) Memory of a computer consists of RAM, ROM and Cache memory.
 (B) Cache memory and RAM are non-volatile memory devices.
 (C) PROM stands for Programmable Read Only Memory.
 Of the above, the correct statement/s is/are
 (1) (A) only. (2) (B) only. (3) (C) only.
 (4) (A) and (B) only. (5) (A) and (C) only.
30. In Graphical User Interface (GUI) designing, **WIMP** is abbreviated for the components
 (1) Windows, Interactions, Mails, Pointer.
 (2) Windows, Icons, Menu, Pointer.
 (3) Web, Icons, Mails, Programmes.
 (4) Web, Interactions, Menu, Programmes.
 (5) Web, Icons, Mails, Pointer.
31. Which one of the following commands should be used to write the equation
 $C_2H_4 + 3O_2 \rightarrow 2CO_2 + 2H_2O$ in a word processor?
 (1) Subscript (2) Italics (3) Superscript (4) Strikethrough (5) Text effects
32. In a typical word processing software F1 key is used to
 (1) open a new file. (2) get help.
 (3) open 'find and replace' dialog box. (4) check spelling.
 (5) save as a new file.

- The question numbers 33 and 34 are based on the following spreadsheet segment. It shows the marks and the corresponding grades obtained by four students for the subject of 'Science for Technology' at the year-end examination of a school.

	A	B	C
1	Name	Marks	Grade
2	Student 1	68	B
3	Student 2	80	A
4	Student 3	75	A
5	Student 4	65	B
6	Average	72	

33. The formula that should be included in B6 cell to obtain the average mark of the students is,
 (1) =MEAN(B2:B5) (2) =AVERAGE(B2:B5)
 (3) =AVERAGE(B2+B3+B4+B5) (4) =COUNT(B2+B3+B4+B5)
 (5) =AVG(B2:B5)
34. The function that should be used to obtain the grade in column C is,
 (1) SUM (2) COUNT (3) IF (4) MAX (5) MIN
35. Which of the following is **not** a view in PowerPoint?
 (1) Presentation view (2) Slide sorter view
 (3) Slide show view (4) Reading view
 (5) Normal view
36. A web address belongs to Sri Lanka is
 (1) www.gov.cn (2) www.ausregistry.com.au
 (3) www.ox.ac.uk (4) www.nic.sl
 (5) www.mohe.gov.lk
37. The most appropriate password for an email account is,
 (1) Sachiperera (2) drged#23@BLo (3) Password123
 (4) Birthday0910 (5) MataraColombo
38. Object A rotates at an angular velocity of 10 rad s^{-1} and its moment of inertia about the rotating axis is 3 kg m^2 . Another object B of mass 12 kg is executing a linear motion with the same kinetic energy as that of the object A. The moving speed of the object B is,
 (1) 1 m s^{-1} (2) 2 m s^{-1} (3) 3 m s^{-1} (4) 4 m s^{-1} (5) 5 m s^{-1}
39. Two liquids in two identical calorimeters are at the same temperature. When heat is supplied to them for a same period of time at a constant rate, the final temperature of both liquids becomes equal. Select the correct statement out of the following.
 (1) Densities of two liquids are equal.
 (2) Masses of two liquids are equal.
 (3) Volumes of two liquids are equal.
 (4) Heat capacities of two liquids are equal.
 (5) Specific heat capacities of two liquids are equal.
40. Under which given situation the maximum heat is dissipated from a circuit having a resistant wire and a cell with negligible internal resistance?
 (1) Connecting the wire to the terminals of the cell.
 (2) Connecting half of the wire to the terminals of the cell.
 (3) Connecting one third of the wire to the terminals of the cell.
 (4) Cutting the wire into two equal pieces and connecting them in parallel to the terminals of the cell.
 (5) Cutting the wire into three equal pieces and connecting them in parallel to the terminals of the cell

41. A water-pump pumps out 1200 kg mass of water per minute from a tube well of 30 m depth. If water is released with a velocity of 3 m s^{-1} , how much work is done, when the pump runs for an hour? Consider the gravitational acceleration as 10 m s^{-2}

(1) 1.69 J (2) 6.09 kJ (3) $3.24 \times 10^2 \text{ kJ}$ (4) $2.16 \times 10^4 \text{ kJ}$ (5) $2.19 \times 10^4 \text{ kJ}$

42. A 20 N m torque is needed to untight a tightened nut. A wrench of length 20 cm is used for this purpose as shown in the figure. What is the minimum force should be applied onto the handle of the wrench to untight the nut?

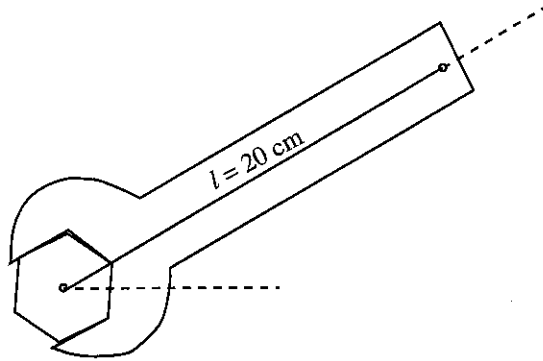

(1) 1 N (2) 5 N (3) 20 N (4) 100 N (5) 200 N

43. Consider the following statements about a transformer.

- (A) Use to vary the magnitude of alternating voltage
 (B) Step up transformers are used in direct current power supplies.
 (C) In step down transformers, the number of turns in the secondary coil is greater than the number of turns in the primary coil.

Of the above, the true statement/s is/are

(1) (A) only. (2) (B) only. (3) (C) only.
 (4) (A) and (B) only. (5) All (A), (B) and (C).

44. A micrometer screw gauge is having a thimble with 50 divisions and a pitch of 0.5 mm. The reading of it as shown in the figure is,

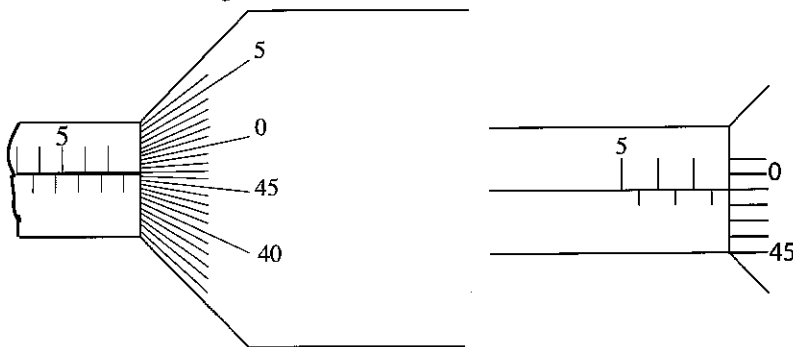

(1) 7.01 mm (2) 7.49 mm (3) 7.51 mm (4) 7.99 mm (5) 8.00 mm

45. When a car is started, its starter motor draws 50 A of current from the battery of 12 V for 1.2 s. How much electrical energy does the battery supply if its internal resistance is negligible?

(1) 5 J (2) 60 J (3) 500 J (4) 600 J (5) 720 J

46. Which of the following statements on thermal radiation is correct?

- (1) A good absorber of thermal radiation is not a good emitter.
 (2) Silver plated glass walls in thermos flask minimize the radiation loss.
 (3) Thermal radiation does not belong to electromagnetic waves.
 (4) Black clothes are recommended for the warm sunny places, as they do not absorb more heat radiation.
 (5) Heat transfers from one place to another only by radiation.

47. A part of a domestic electrical circuit is shown in the figure. X, Y and Z are three electrical apparatus in it. Which is the best position to fix a circuit breaker in order to protect the circuit in the event of short-circuit at any apparatus?

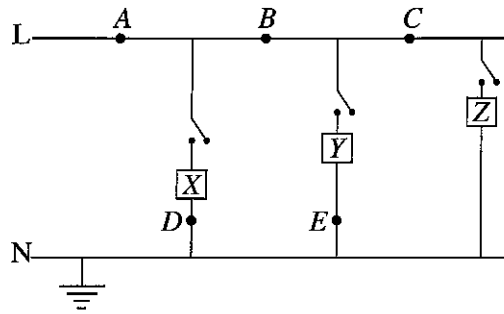

- (1) A (2) B (3) C (4) D (5) E
48. Which of the following statements on stretched wire is correct?
- (1) The product of tension and extension gives elastic potential energy stored in it.
 - (2) Even if the wire is stretched beyond its elastic limit, it will return to the initial length upon removal of the stress.
 - (3) Tension of the wire is proportional to its extension within the proportional limit.
 - (4) Stress is equal to the product of the force applied and the cross-sectional area of the wire.
 - (5) The wire can be stretched only after its elastic limit.
49. The blood flowing rate from the heart of a person at rest is 6 litres per minute and this volume passes through the capillaries at an average speed of 1 mm s^{-1} . A schematic of one capillary is given below. Assume that blood is an incompressible fluid having laminar flow.

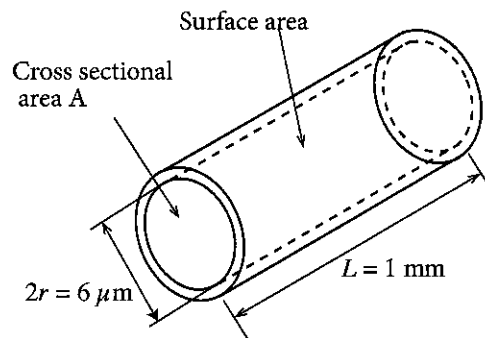

If $\pi = 3$, the number of capillaries in the body is,

- (1) 7.3×10^6 (2) 9.3×10^8 (3) 3.7×10^9 (4) 5.6×10^{10} (5) 2.2×10^{11}
50. In a part of a current balance, a conducting wire is connected between A and B points of the plastic frame and the system is balanced on the horizontal plane as shown in the figure. The length of the wire is 10 cm and a uniform horizontal magnetic field with $2 \times 10^{-3} \text{ T}$ flux density is applied across the wire. If an electric current of 10 A flows in the wire from A to B, what is the mass required to keep on the pan in order to balance the system on the same horizontal plane? Consider the gravitational acceleration as 10 m s^{-2} .

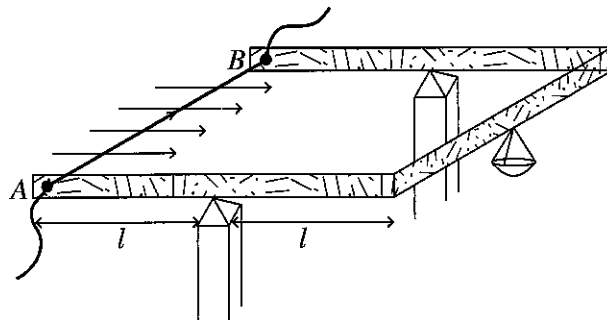

- (1) 0.02 g (2) 0.20 g (3) 2.00 g (4) 0.20 kg (5) 2.00 kg

සියලු ම හිමිකම් ඇවිරිණි / முழுப் பதிப்புரிமையுடையது / All Rights Reserved

ශ්‍රී ලංකා විභාග දෙපාර්තමේන්තුව ශ්‍රී ලංකා විභාග දෙපාර්තමේන්තුව ශ්‍රී ලංකා විභාග දෙපාර්තමේන්තුව ශ්‍රී ලංකා විභාග දෙපාර්තමේන්තුව
 இலங்கைப் பரீட்சைத் திணைக்களம் இலங்கைப் பரීட்சைத் திணைக்களம் இலங்கைப் பரීட்சைத் திணைக்களம் இலங்கைப் பரීட்சைத் திணைக்களம்
 Department of Examinations, Sri Lanka Department of Examinations, Sri Lanka Department of Examinations, Sri Lanka Department of Examinations, Sri Lanka
 இலங்கைப் பரීட்சைத் திணைக்களம் இலங்கைப் பரීட்சைத் திணைக்களம் இலங்கைப் பரීட்சைத் திணைக்களம் இலங்கைப் பரීட்சைத் திணைக்களம்
 Department of Examinations, Sri Lanka

අධ්‍යයන පොදු සහතික පත්‍ර (උසස් පෙළ) විභාගය, 2018 අගෝස්තු
 கல்விப் பொதுத் தராதரப் பத்திர (உயர் தர)ப் பரீட்சை, 2018 ஓகஸ்ட்
 General Certificate of Education (Adv. Level) Examination, August 2018

නාක්ෂණවේදය සඳහා විද්‍යාව II
 தொழினுட்பவியலுக்கான விஞ்ஞானம் II
 Science for Technology II

67 E II

17.08.2018 / 0830 - 1140

පැය තුනයි

மூன்று மணித்தியாலம்
 Three hours

අමතර කියවීමේ කාලය - මිනිත්තු 10 යි
 மேலதிக வாசிப்பு நேரம் - 10 நிமிடங்கள்
 Additional Reading Time - 10 minutes

Use additional reading time to go through the question paper, select the questions and decide on the questions that you give priority in answering.

Index No. :

Instructions :

- * This question paper consists of 11 pages.
- * This question paper comprises of four Parts A, B, C and D. The time allotted for all parts is three hours.
- * Use of calculators is not allowed.

Part A - Structured Essay (Pages 2 - 6)

- * Answer all the questions on this paper itself.
- * Write your answers in the space provided for each question. Note that the space provided is sufficient for your answers and that extensive answers are not expected.

Parts B, C and D - Essay (Pages 7 - 11)

- * Select minimum of one question from each of the parts B, C and D and answer four questions only. Use the papers supplied for this purpose. At the end of the time allotted for this paper, tie all parts together so that Part A is on the top of Parts B, C and D before handing over to the supervisor.
- * You are permitted to remove only Parts B, C and D of the question paper from the examination hall.

For Examiners' Use Only

Part	Q. No.	Marks
A	1	
	2	
	3	
	4	
B	5	
	6	
C	7	
	8	
D	9	
	10	
Total		
Percentage		

Final Marks

In Numbers	
In Words	

Code Numbers

Marking Examiner 1	
Marking Examiner 2	
Checked by	
Supervised by	

Do not write in this column

2. Calorific value (amount of heat produced on complete burning of 1 g of fuel) of wood is less than LP gas. Technologically advanced Gliricidia wood pellets have a greater calorific value compared to typical wood based fuel. Gliricidia (*Gliricidia sepium*) is commonly used in wood pellet production industries in Sri Lanka.

Chemical reaction of the combustion of the Gliricidia pellets can be given as follows.

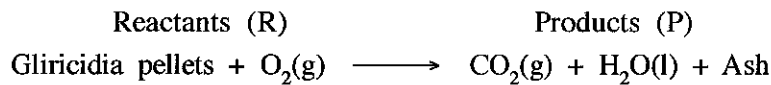

(a) (i) Is the combustion of wood fuel an endothermic or exothermic?

.....

(ii) For the above combustion, mark the energy positions of the reactants (R) and the products (P) on the relevant energy levels in the given diagram below.

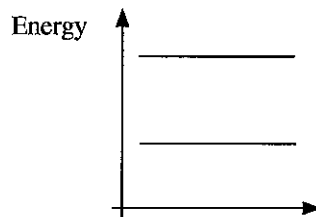

(iii) State **two** environmental advantages of using Gliricidia wood pellets over LP gas to produce energy.

(1)

(2)

(b) A sketch of the experimental setup to determine the calorific values of Gliricidia wood and Gliricidia wood pellets is given in the figure. A mass of 500 g of water is used for the experiment. The specific heat capacity of water is 4.2 J °C⁻¹ g⁻¹. The water at the initial temperature of 32 °C has warmed up to final temperature of 62 °C when a mass of 15 g of Gliricidia pellets combusted for the experiment.

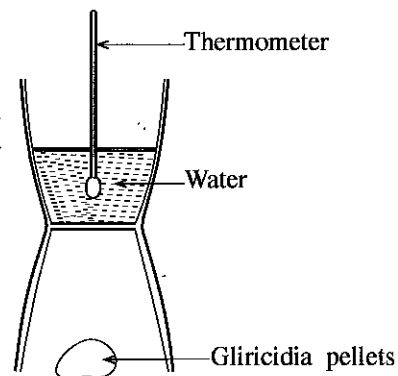

(i) Calculate the amount of heat absorbed by water.

.....

(ii) The time taken for the combustion of 15 g of Gliricidia wood pellets is 20 minutes. Calculate the rate of combustion in g min⁻¹.

.....

(iii) Calculate the calorific value of Gliricidia wood pellets used for the experiment.

.....

Do not write in this column

Q.2

100

(iv) Standard calorific value reported in literature is greater than the calorific value of Gliricidia wood pellets obtained from this experiment. State **one** possible reason for this observation.

.....

3. (a) You have been asked to design and perform an experiment in the laboratory to determine the specific latent heat of fusion of ice using the method of mixtures. A thermally insulated copper calorimeter with water and a stirrer with a mesh, small ice pieces, blotting papers, a triple beam balance, a thermometer and a Bunsen burner are provided.

(i) State **one** advantage of using a thermally insulated calorimeter.

.....

(ii) What are the **three** measurements obtained before adding ice to the calorimeter?

X₁:

X₂:

X₃:

(iii) State **two** precautionary steps that you should follow when ice is added into the calorimeter.

(1)

(2)

(iv) What are the **two** measurements obtained after finishing the process of adding ice to the calorimeter?

X₄:

X₅:

(v) If L is the specific latent heat of fusion of ice, C_w is the specific heat capacity of water and C is the specific heat capacity of copper,

(1) write an expression for the heat gained in terms of the measurements you obtained when melting ice.

.....

(2) write an expression for the heat emitted by water and the calorimeter in terms of the measurements you obtained.

.....

(3) write an equation to determine the specific latent heat of fusion of ice using the above expressions.

.....

(vi) Write a reason for not using powdered ice instead of small ice pieces in this experiment.

.....

Do not write in this column

(b) (i) Explain why ice is transported as large pieces.

.....

(ii) Fishes are stored in synthetic polymer boxes with ice pieces for preservation. What is the scientific reason to use synthetic polymer boxes?

.....

(iii) In transportation, ice pieces are embedded in wooden flakes. Give the scientific reason for this.

.....

(iv) What is the biological reason for preserving fishes at low temperature?

.....

(v) There are 10 kg of fish in a heat insulated box at 30°C temperature. Calculate the mass of ice that is needed to decrease the temperature of fish to 15°C.

The specific latent heat of fusion of ice is $3.33 \times 10^5 \text{ J kg}^{-1}$ and the specific heat capacity of water is $4200 \text{ J } ^\circ\text{C}^{-1} \text{ kg}^{-1}$. Assume that the average specific heat capacity of the body materials of fish is $2640 \text{ J } ^\circ\text{C}^{-1} \text{ kg}^{-1}$.

.....

Q.3

100

4. The given diagram shows a setup used to lift a mixture of concrete at a building construction site. A light cable has been wound around the pulley. One end of the cable has been attached to the pulley and the other end to the bucket. When the pulley is rotated by the electric motor, the bucket is lifted by winding the cable around the pulley. Consider the gravitational acceleration as 10 m s^{-2} and the ground as the level of zero potential.

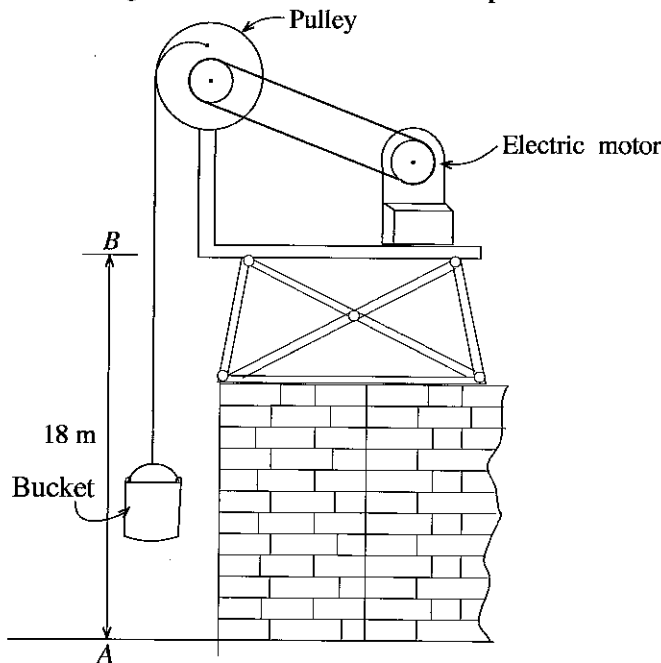

(a) (i) The bucket with concrete mixture is performing motion.

(ii) Pulley is performing motion.

(iii) Mark the forces acting on the bucket in the diagram.

(iv) Mark the forces acting on the pulley in the diagram, if the pulley with the axle is rotated around a smooth axis.

Do not write in this column

(b) (i) Calculate the tension of the cable when it is lifting at an acceleration of 2 m s^{-2} and if the mass of the bucket with the concrete mixture is 100 kg.

.....
.....

(ii) What is the angular acceleration of the pulley if the radius of it is 25 cm?

.....
.....

(iii) What is the effective torque acting on the pulley if the moment of inertia of the pulley with the axle is 25 kg m^2 ?

.....
.....

(c) The bucket with the concrete mixture is lifted at 18 m height at 6 seconds and stopped.

(i) What is the potential energy gained by the bucket with the mixture?

.....
.....

(ii) What is the output power of the motor?

.....
.....

(iii) What is the efficiency of the setup if the input power of the motor is 5 kW?

.....
.....

(d) Will the change of radius of the pulley affect the efficiency of the setup?

.....
.....

Justify your answer scientifically.

.....
.....

(e) If the rotating axle of the pulley in the setup is rough, is the efficiency of the setup decreasing or increasing or not changing?

.....
.....

Briefly write the scientific reason for your answer.

.....
.....

* *

Q.4

100

සියලු ම හිමිකම් ඇවිරිණි / முழுப் பதிப்புரிமையுடையது / All Rights Reserved

ශ්‍රී ලංකා විභාග දෙපාර්තමේන්තුව ශ්‍රී ලංකා විභාග දෙපාර්තමේන්තුව ශ්‍රී ලංකා විභාග දෙපාර්තමේන්තුව ශ්‍රී ලංකා විභාග දෙපාර්තමේන්තුව ශ්‍රී ලංකා විභාග දෙපාර්තමේන්තුව
 இலங்கைப் பரீட்சைத் திணைக்களம் இலங்கைப் பரීட்சைத் திணைக்களம் இலங்கைப் பரීட்சைத் திணைக்களம் இலங்கைப் பரීட்சைத் திணைக்களம் இலங்கைப் பரීட்சைத் திணைக்களம்
 Department of Examinations, Sri Lanka Department of Examinations, Sri Lanka Department of Examinations, Sri Lanka Department of Examinations, Sri Lanka Department of Examinations, Sri Lanka

අධ්‍යයන පොදු සහතික පත්‍ර (උසස් පෙළ) විභාගය, 2018 අගෝස්තු
கல்விப் பொதுத் தராதரப் பத்திர (உயர் தர)ப் பரீட்சை, 2018 ஆகஸ்ட்
General Certificate of Education (Adv. Level) Examination, August 2018

තාක්ෂණවේදය සඳහා විද්‍යාව தொழினுட்பவியலுக்கான விஞ்ஞானம் Science for Technology	II II II	Essay	67	E	II
--	----------------	--------------	-----------	----------	-----------

Instructions:

- * Select minimum of one question each from parts B, C and D and answer four questions only.
- * Each question carries 15 marks.
- * Graph sheet for question number 6 in part B is provided with the question paper.

Part B - Essay

5. The floor plan of an equilateral hexagonal shaped old fort is shown in figure 01. The centre of the fort is O and the side length is 60m. The main entrance of the fort is at the AB wall and shape of it is depicted in figure 02. There are 6 similar towers in A, B, C, D, E and F corners and the shape of a tower is shown in figure 03 (Consider $\pi=3.14, \sqrt{26} = 5.01$ and $\sqrt{3} = 1.73$ in calculations).

	30°	45°	60°
sin	$\frac{1}{2}$	$\frac{1}{\sqrt{2}}$	$\frac{\sqrt{3}}{2}$
cos	$\frac{\sqrt{3}}{2}$	$\frac{1}{\sqrt{2}}$	$\frac{1}{2}$
tan	$\frac{1}{\sqrt{3}}$	1	$\sqrt{3}$

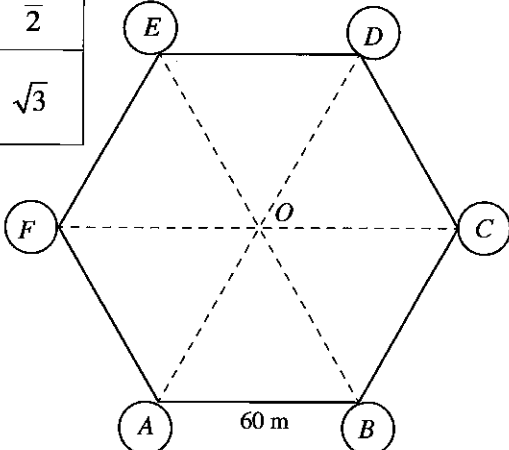

Figure 01

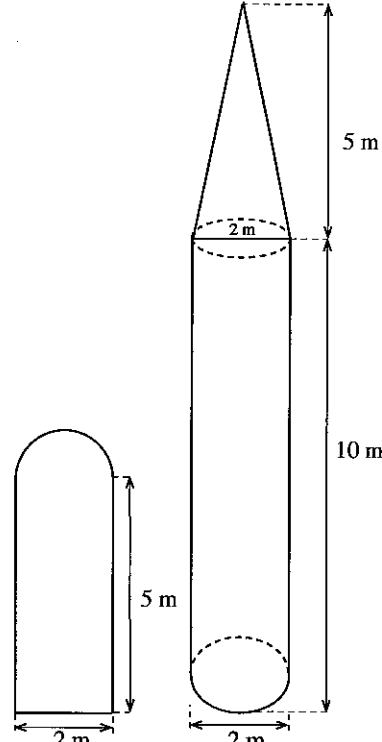

Figure 02

Figure 03

- (a) Using the data in the given figures, calculate the following.
 - (i) Length of FO
 - (ii) Area of the base of a tower
 - (iii) Floor area of section $ABCF$
 - (iv) Area of the inner floor of the fort
- (b) The door at the main entrance is made of 0.3 m thick wood. The shape of the upper part of the door is semi-circular as shown in figure 02.
 - (i) Calculate the area of the front surface of the door.
 - (ii) The mass of a cubic metre of wood used to make the door is 100 kg. Calculate the mass of the door.
- (c) If the tower given in figure 03 consists of a cylindrical part and a right circular cone, calculate the surface area of a tower. (excluding the base).
- (d) Obtain the tangent value of the angle of elevation to the top of the tower located at the position F as seen by a child at the position O whose eye level is 1 m above the ground.

6. (a) Amount of carbon monoxide emission is measured at the vehicle emission test. Amounts of carbon monoxide obtained by testing 50 petrol cars are given in the following grouped frequency distribution.

Table 1: Grouped frequency distribution for petrol cars

Class limits	Number of vehicles (frequency)	Class boundary	Class mark	Cumulative frequency	Percentage cumulative frequency
0.1–1.0	02				
1.1–2.0	03				
2.1–3.0	10				
3.1–4.0	20				
4.1–5.0	08				
5.1–6.0	05				
6.1–7.0	02				

- Complete class boundary, class mark, cumulative frequency and percentage cumulative frequency columns in the Table 1 above.
 - Using the grouped frequency distribution, calculate the mean of the amount of carbon monoxide emitted by petrol cars.
 - Draw the percentage cumulative frequency curve for the above distribution on the graph paper provided.
 - According to the current law, the petrol cars with carbon monoxide emission greater than 4.5 are considered as not roadworthy. Find the percentage of unroadworthy petrol cars, using the percentage cumulative frequency curve.
- (b) Amount of carbon monoxide obtained for 20 trishaws are tabulated as follows.

Table 2: Ungrouped frequency distribution for trishaws.

Amount of Carbon monoxide	Number of vehicles
3.5	02
4.1	02
4.8	01
5.2	01
5.7	03
6.0	05
6.3	01
6.5	02
7.4	03

- Calculate the range of the middle 50% of the amounts of carbon monoxide emitted by trishaws.
- Complete the following table using the data given in the Table 2.

Table 3 : Grouped frequency distribution for trishaws

Class limit	Number of vehicles
3.1 – 4.0	
4.1 – 5.0	
5.1 – 6.0	
6.1 – 7.0	
7.1 – 8.0	

- Using the grouped frequency distributions given in Table 1 and Table 3, determine which type of vehicle has the higher dispersion in amounts of carbon monoxide. Justify your answer.
- Obtain a single grouped frequency distribution for two types of vehicles using Table 1 and Table 3. (It is enough to show the 'class limit' and the 'number of vehicles' in the new distribution).

Part C - Essay

7. Based on current investigations, it has been reported that a larger amount of plastic dumped into the ocean has been collected on the Pacific Ocean surface. It has been estimated that the amount of plastic floating on the ocean surface is approximately 80,000 metric tons. The region with this plastic garbage collected is known as the 'Great Pacific Garbage Patch'.
- (a) (i) Is plastic a synthetic polymer or a natural polymer?
(ii) State one major advantage of plastics.
(iii) State one major disadvantage of plastics.
(iv) State **two** actions that can be taken to minimize the environmental impact of plastics.
(v) State one possible effect on human due to burning of plastics.
(vi) What is the impact of the 'Great Pacific Garbage Patch' on the fish population in Pacific Ocean?
- (b) Drinking water is a limited natural renewable resource. National Water Supply and Drainage Board distributes water suitable to drink after processing.
- (i) Water cycle is a natural cycle. Describe it.
(ii) What are the **two** cations responsible for the permanent hardness of water?
(iii) Name a chemical that is used by the National Water Supply and Drainage Board to remove mud particles during the water purification process.
(iv) Water distributed by the National Water Supply and Drainage Board must not be used to wash vehicles and watering plants. Briefly explain the reason for this.
- (c) An activity performed by a student using the waste plastic bottles is described below.
A used plastic bottle filled with water was tightly closed with a lid and dipped in the cistern of the toilet by the student. This reduced the volume of water required to fill the cistern by 1 litre. Due to this, the amount of water required to flush the toilet once can be reduced by 1 litre.
- (i) What is the amount of water that can be saved in a school, which uses the toilet 1000 times per day, for 30 days?
(ii) If one unit of water is 1000 litre, what is the number of units that can be saved by this method for 30 days?
(iii) Use of liquid soap to wash hands after using toilet is a common practice. State one environmental issue that can occur as a result of the release of waste water containing liquid soap.
(iv) Suggest a method to reuse waste water containing hand washed liquid soap within the toilet to encourage the water management.
8. Resources required to start an industry can be divided into five groups according to the 5M concept.
- (a) Two essential resource groups listed by this concept are Methods and Materials.
- (i) According to the 5M concept, what are the other **three** resource groups required to start an industry?
(ii) State **two** factors that must be considered when selecting raw materials.
(iii) In the modern 5M concept, Methods and Materials are considered as one group and Marketing is included as a new group. Explain the importance of this group.
- (b) The organic solvent in expired enamel paints can be recovered using distillation and can be used again for paint production.
- (i) What is the function of organic solvent present in enamel paint?
(ii) What is the solvent used in emulsion paint?
(iii) Why is the use of emulsion paint is more environmental friendly compared to the enamel paint?
(iv) State **two** advantages that a producer can gain by using organic solvent recovered from expired paint for the production of enamel paints in Sri Lanka.
(v) What is the main property of the solvent that must be considered when selecting a solvent for the production of a paint that dries quickly?
(vi) State **two** physio-chemical changes that take place during the drying process of enamel paint after application.

(c) A method suggested by a student to apply super phosphate fertilizer to a cultivation located on a steep mountain region with higher precipitation is shown in the diagram. Water is poured into clay pots with fertilizer buried in the ground parallel to the cultivation. Water with fertilizer is slowly dripped into the soil through the walls of clay pots.

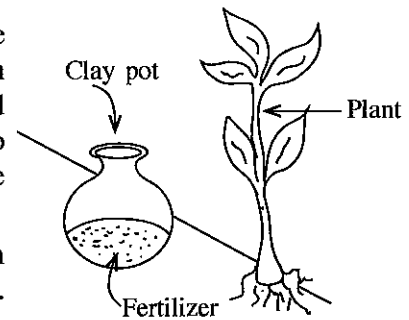

- (i) State one economical and environmental disadvantage each of using larger amounts of fertilizers to obtain greater yields.
- (ii) Name the city in which the largest phosphate deposit consisting of phosphate in Sri Lanka.
- (iii) What is the disadvantage of addition of super phosphate fertilizer to a cultivation located on a steep mountain region having a high precipitation?
- (iv) How can the disadvantage stated in part (iii) be minimized by the method proposed by the student?
- (v) State a possible disadvantage of the method proposed by the student.

Part D - Essay

9. A stadium in Sri Lanka is fitted with 4 lighting poles at 4 corners to provide uniform lighting to the playground in the night. Each pole has 60 numbers of 2 kW Halide lamps. Spectator stands and other areas have 500 numbers of 100 W CFL lamps and 150 numbers of 200 W industrial fans.

- (a) When all the lamps and fans are switched ON for 6 hours for a night match, calculate the electrical consumption of the following in kWh.
 - (i) by all the fans in the stadium
 - (ii) by all the CFL lamps in the stadium
 - (iii) by all the halide lamps in the stadium
- (b) Every month, ten night matches are played in the stadium under floodlight. If the price for one unit of electric power is Rs. 45, calculate the amount of the monthly electricity bill for the stadium.
- (c) (i) Name **three** sources, which are mainly used to produce electricity in Sri Lanka.
Under the government 'Soorya Bala Sangramaya' project, it is suggested to install solar panels on the roofs of the spectator stands. A solar panel of 1 kW with the surface area of 8 m² can generate 120 kWh electrical energy in a month.
 - (ii) Write **two** advantages and **two** disadvantages of using solar panels.
 - (iii) Calculate the minimum number of solar panels required to be installed at the stadium to meet its monthly electrical consumption requirement.
 - (iv) Assuming that all the solar panels are to be fixed only within the roof area of the stadium, calculate the minimum roof area needed to hold the required number of solar panels obtained in part (c)(iii) above.
 - (v) If the cost of installing 1 kW solar panel with required components to connect to the national grid is Rs. 300 000,
 - (1) what is the total cost for installing the minimum number of solar panels to meet the monthly requirement of the stadium?
 - (2) how long would it take in years to recover the investment on the installation of solar panels?
- (d) Net-Metering plan allows consumers to generate electricity through solar panels and set off the power generated against the power consumed from the national grid. Consumer pays only for the 'net' number of units (difference between import and export electrical energy) every month. What is the main advantage of using the net-metering arrangement at the stadium?

10. (a) Two cubes A and B each having volume V , are made of materials of densities ρ_1 and ρ_2 , respectively. These two cubes are kept closer to the middle of a tall vessel filled with water as shown in the figure and gently released them.

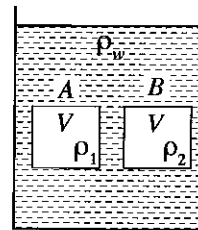

Consider that the density of water is ρ_w and $\rho_1 > \rho_w$ and $\rho_2 < \rho_w$, g is the gravitational acceleration.

- (i) Write expressions for the weights of A and B using the given terms.
 - (ii) Write an expression for the upthrust acting on A and B .
 - (iii) Once A and B are released, what would be the directions of motion of them? Justify your answer by considering the expressions obtained in (a)(i) and (a)(ii).
- (b) When a hydrometer floats in water, 25 cm of its stem is dipped in water. When it floats in another liquid, 20 cm of its stem is dipped in the liquid. Find the relative density of the liquid.
- (c) For what purpose the following apparatus are used?
- (1) Lactometer
 - (2) Metrolac
- (d) The figure shows the shape of a roof and the airflow over it during a cyclone.

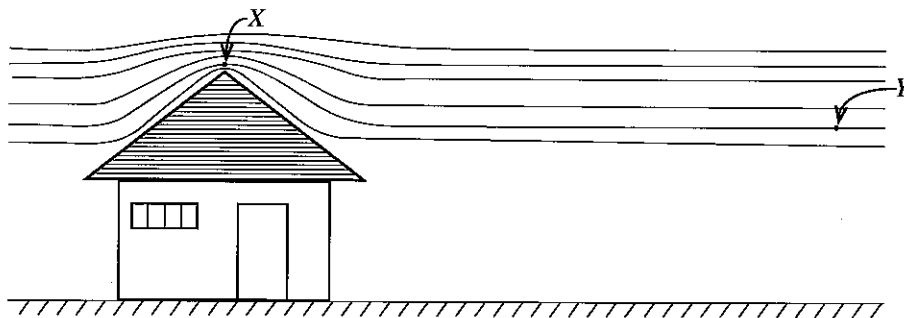

Points X and Y are on a same streamline of the wind flow and they are far apart enough to neglect the difference in their heights.

- (i) At which point the wind flow has higher velocity?
- (ii) At which point the wind flow has higher pressure?
- (iii) If v_1 and v_2 are the velocities and P_1 and P_2 are the pressures of the wind flow at X and Y respectively, write the Bernoulli equation. Let ρ be the density of air.
- (iv) If the effective area of the roof is 200 m^2 , the velocity of wind flow at point X is 360 km h^{-1} and the density of air is 1.3 kg m^{-3} , calculate the force acting on the roof due to the wind flow (Consider the velocity of wind inside the house as zero).
- (v) A student says that the roof of a house is safe if the windows and doors are opened during a rapid wind flow. Do you agree with this statement? Explain your answer.



තාක්ෂණවේදය සඳහා විද්‍යාව
தொழினுட்பவியலுக்கான விஞ்ஞானம்
Science for Technology

II
II
II

67 II

ප්‍රශ්න අංකය
வினா இல. } 6. (a) (iii)
Question No.

