

නව/පැරණි කීර්දේශය - ප්‍රතිපාදන පාලන කමිටුව - New/Old Syllabus

ශ්‍රී ලංකා විභාග දෙපාර්තමේන්තුව ශ්‍රී ලංකා විභාග දෙපාර්තමේන්තුව ශ්‍රී ලංකා විභාග දෙපාර්තමේන්තුව ශ්‍රී ලංකා විභාග දෙපාර්තමේන්තුව ශ්‍රී ලංකා විභාග දෙපාර්තමේන්තුව
 இலங்கைப் பரீட்சைத் திணைக்களம் இலங்கைப் பரීட்சைத் திணைக்களம் இலங்கைப் பரීட்சைத் திணைக்களம் இலங்கைப் பரීட்சைத் திணைக்களம் இலங்கைப் பரීட்சைத் திணைக்களம்
 Department of Examinations, Sri Lanka Department of Examinations, Sri Lanka Department of Examinations, Sri Lanka Department of Examinations, Sri Lanka Department of Examinations, Sri Lanka
 இலங்கைப் பரීட்சைத் திணைக்களம் இலங்கைப் பரීட்சைத் திணைக்களம் இலங்கைப் பரීட்சைத் திணைக்களம் இலங்கைப் பரīட்சைத் திணைக்களம் இலங்கைப் பரīட்சைத் திணைக்களம்
 Department of Examinations, Sri Lanka

NEW/OLD

අධ්‍යයන පොදු සහකීක පත්‍ර (උසස් පෙළ) විභාගය, 2019 අගෝස්තු
 கல்விப் பொதுத் தராதரப் பத்திர (உயர் தர)ப் பரீட்சை, 2019 ஓகஸ்ட்
 General Certificate of Education (Adv. Level) Examination, August 2019

15.08.2019 / 1300 - 1500

සිවිල් තාක්ෂණවේදය I
 குடிசார்த் தொழினுட்பவியல் I
 Civil Technology I

14 E I

පැය දෙකයි
 இரண்டு மணித்தியாலம்
 Two hours

Instructions:

- * Answer all the questions.
- * Write your Index Number in the space provided in the answer sheet.
- * Use of calculators is not allowed.
- * Instructions are given on the back of the answer sheet. Follow them carefully.
- * In each of the questions 1 to 50, pick one of the alternatives from (1), (2), (3), (4), (5) which is correct or most appropriate and mark your response on the answer sheet with a cross (x) in accordance with the instructions given in the back of the answer sheet.

1. Of which of the following is the 'light year' a unit?
 (1) light intensity (2) mass (3) time (4) distance (5) frequency

- Answer questions 2 to 3 using the following graph.

The graph shows the motion of a landing aircraft after it touches down the runway. After 3 seconds of sudden deceleration, it moves in a constant velocity of 10 m/s until 6th second.

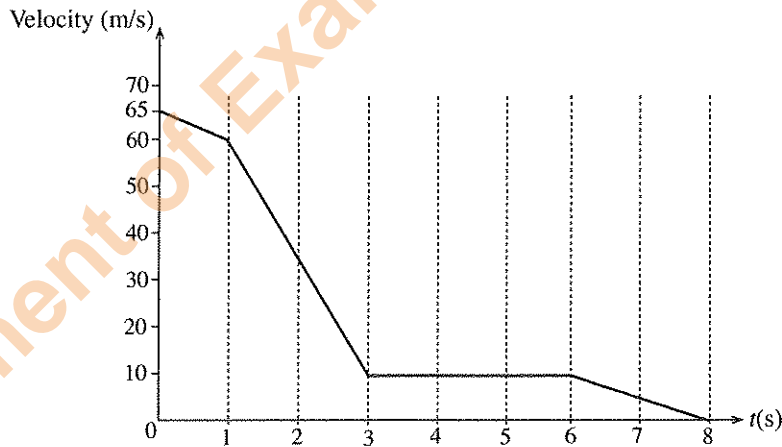

2. What is the displacement of the aircraft during its first 3 seconds?
 (1) 132.5 m (2) 140 m (3) 185 m (4) 212.5 m (5) 215 m
3. What is the average deceleration of the aircraft, if it comes to a stop in 8 seconds?
 (1) $[(65 - 60) / 1 + (60 - 10) / 2 + (10 - 0) / 5] + 8 \text{ ms}^{-2}$
 (2) $[(65 - 60) / 1 + (60 - 10) / 2 + (10 - 0) / 5] \text{ ms}^{-2}$
 (3) $(65 - 60) / 3 + (10 - 0) / 5 \text{ ms}^{-2}$
 (4) $(65 - 0) / 4 \text{ ms}^{-2}$
 (5) $(65 - 0) / 8 \text{ ms}^{-2}$

4. Select the resistor arrangement which has the lowest resistance between points A and B.

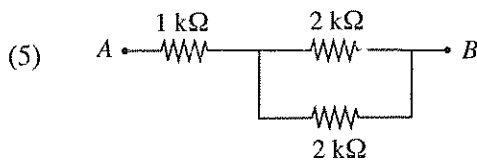
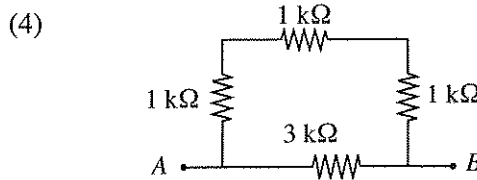
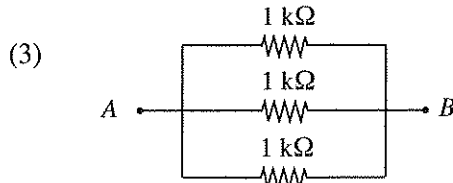
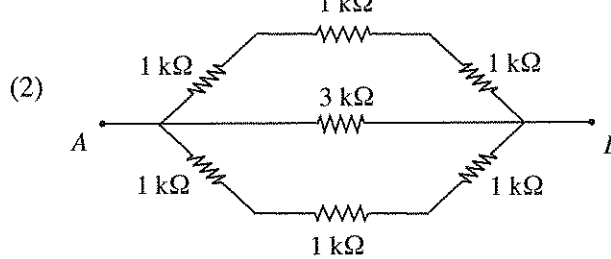
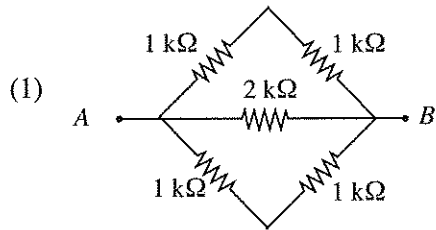

5. Consider following battery arrangements prepared by a student. What are the minimum voltage (V_{min}) and maximum voltage (V_{max}) obtained between A and B points?

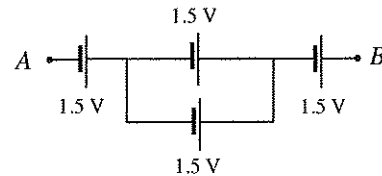
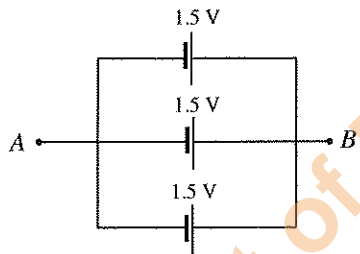
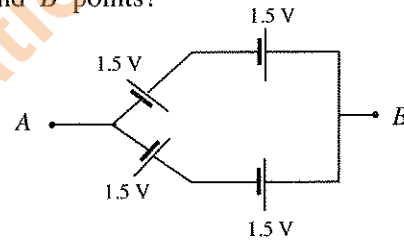
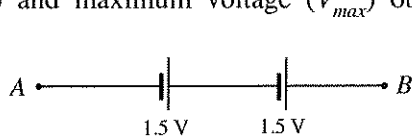

- (1) $V_{min} = 0.5 \text{ V}$, $V_{max} = 4.5 \text{ V}$ (2) $V_{min} = 1.5 \text{ V}$, $V_{max} = 4.5 \text{ V}$
 (3) $V_{min} = 1.5 \text{ V}$, $V_{max} = 3.0 \text{ V}$ (4) $V_{min} = 3.0 \text{ V}$, $V_{max} = 4.5 \text{ V}$
 (5) $V_{min} = 5.0 \text{ V}$, $V_{max} = 15.0 \text{ V}$

6. Three ideal voltmeters and one ideal ammeter are connected in a circuit as shown in the figure. What is the correct answer with correct reading of M_1 , M_2 , M_3 and M_4 in same order?

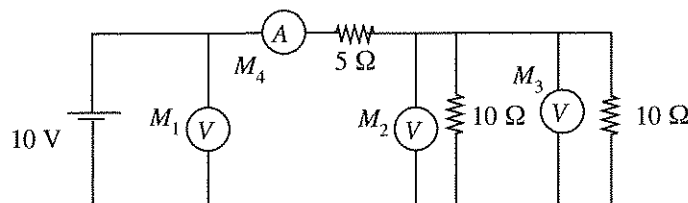

- (1) 5 V, 2.5 V, 2.5 V, 1 A (2) 10 V, 5 V, 5 V, 2 A (3) 10 V, 10 V, 5 V, 1 A
 (4) 10 V, 5 V, 5 V, 1 A (5) 5 V, 5 V, 5 V, 2 A
7. Select the answer with correct parameters of standard domestic electricity supply of Sri Lanka.
- (1) 230 V AC, 60 Hz (2) 230 V DC, 50 Hz (3) 230 V AC, 50 Hz
 (4) 260 V AC, 60 Hz (5) 260 V AC, 90 Hz

Department of Examinations, Sri Lanka.

8. Which of the following is **not** a software used in computer?

- (1) MS Office (2) C++ (3) JAVA
 (4) MS Word (5) Hard disk

9. Figure A and B show two V-pulleys driven by a V-belt and a round rope respectively. Belt and rope both do not touch the flat surface of the V-groove and the shape of the rope remains unchanged. Select the correct statement from the following about its functioning.

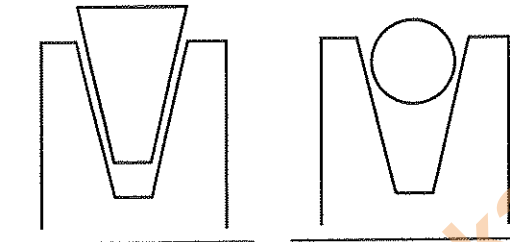

Figure A

Figure B

- (1) V-belt and rope should have same tension before slip.
 (2) V-belt slips first.
 (3) Rope slips first.
 (4) Slip cannot be analytically explained.
 (5) Slip depends on the diameter of the rope.

10. A common function of solar PV cells and Solar hot water heaters is

- (1) generation of electricity. (2) generation of heat.
 (3) generation of water. (4) generation of both heat and electricity.
 (5) generation of noise.

11. Which of the following energy forms can be converted into work in a most efficiently way?

- (1) electricity (2) heat (3) pneumatic (4) sea wave (5) wind

12. Consider the following statements on renewable energy sources.

- A - Solar energy is renewable.
 B - Biomass is non-renewable.
 C - Coal is renewable.
 D - Hydro power is non-renewable.

Which of the above statements are **incorrect**?

- (1) A, B and C only. (2) A, B and D only. (3) A, C and D only.
 (4) B, C and D only. (5) All A, B, C and D.

13. What measuring instrument can be used to accurately measure the depth (h) and the internal diameter (d) of a test tube?

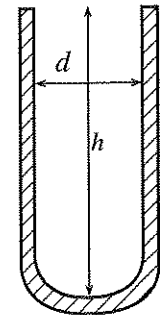

- (1) Micrometer screw gauge
 (2) Meter ruler
 (3) Vernier calliper
 (4) Measuring tape
 (5) Protractor

14. Which option gives the plan view of the machine component shown in figure?

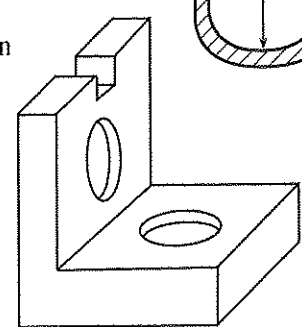

- (1) (2) (3) (4) (5)

[See page four

Department of Examinations, Sri Lanka.

- A bar is at a stable position as in the figure below. Use the figure to answer questions 15 and 16.

15. Select the correct answer.

- (1) $\omega = T, Q + T \cos 30^\circ = W$
- (2) $\omega = T \cos 30^\circ, Q + T = W$
- (3) $\omega = T, Q + T = W$
- (4) $\omega = T \sin 30^\circ, Q - T \cos 30^\circ = W$
- (5) $\omega = 2T, Q + T \cos 30^\circ = W$

16. What is the value of P ?

- (1) ω
- (2) $\omega \sin 30^\circ$
- (3) $\omega \cos 30^\circ$
- (4) $W + \omega \sin 30^\circ$
- (5) $W + \omega$

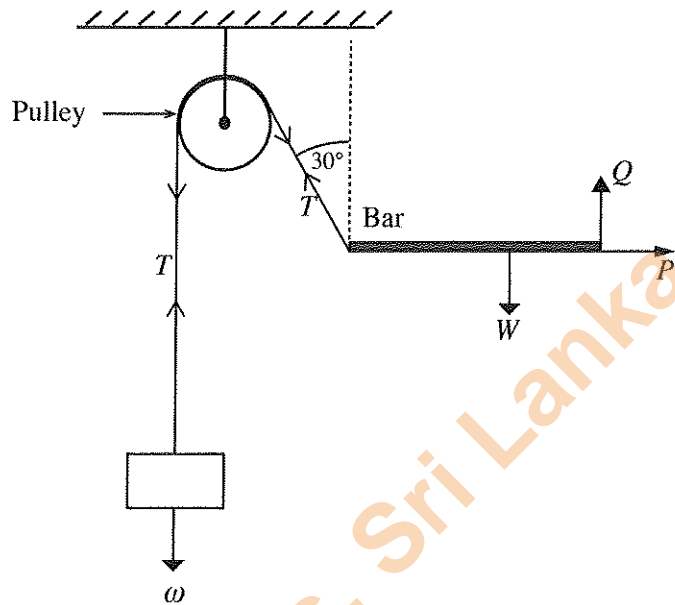

17. Consider the following statements.

- A - Frictional coefficient between two metal is higher than that of metal on ice.
- B - Frictional coefficient is expected to reduce when a surface begins to move over the other.
- C - Sand is sometimes used to increase traction between two surfaces.
- D - Surface roughness has negligible influence when determining the theoretical frictional force.

Which of the above statements are true about sliding between two surfaces?

- (1) A, B and C only.
- (2) A, B and D only.
- (3) A, C and D only.
- (4) B, C and D only.
- (5) All A, B, C and D.

18. A 10 W LED Lamp is installed in a house. It is consuming 10% more power due to an internal fault in the lamp. It is switched ON for 5 hours daily. What is the monthly (30 days) energy consumption?

- (1) 0.165 kWh
- (2) 0.55 kWh
- (3) 1.65 kWh
- (4) 5.5 kWh
- (5) 16.5 kWh

19. When extinguishing a fire caused due to a volatile flammable liquid, best material to be used is

- (1) dry chemical spray.
- (2) carbon dioxide jet.
- (3) compressed air jet.
- (4) water jet.
- (5) foam extinguisher.

20. A human being inhales about 78% Nitrogen, 21% Oxygen and 1% others. Exhales 4% Water vapour, 75% Nitrogen, 16% Oxygen, and 4% Carbon dioxide. Which of the following statements are true?

- A - The body uses oxygen to breakdown foods to create energy.
- B - Carbon dioxide is produced by human cells.
- C - Water vapour is produced from moisture in the respiratory system.
- D - Exhaled air is warmer than the inhaled air.

- (1) A, B and C only.
- (2) A, B and D only.
- (3) A, C and D only.
- (4) B, C and D only.
- (5) All A, B, C and D.

21. A vehicle travels along a straight road from point A to B and its velocity is as shown in the figure below.

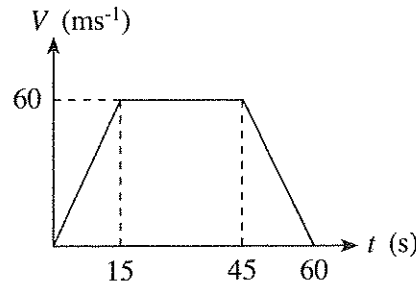

Which diagram indicates the acceleration (a) of the vehicle?

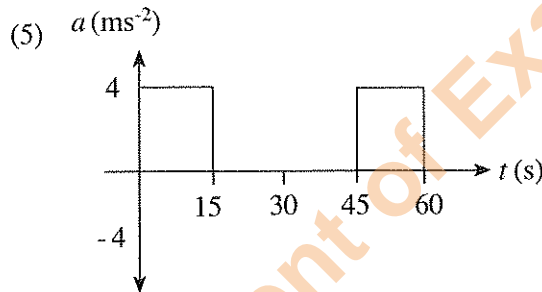
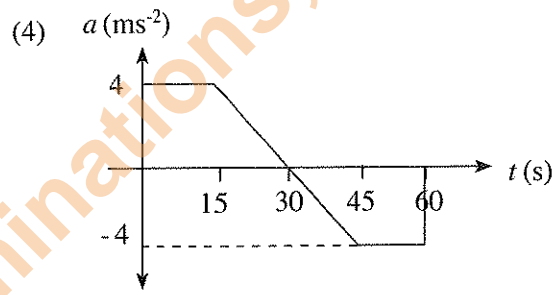
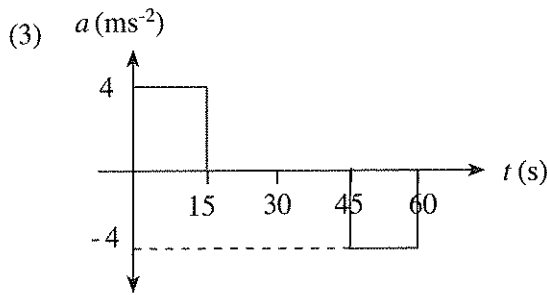
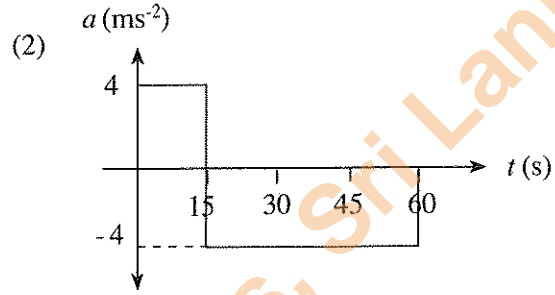
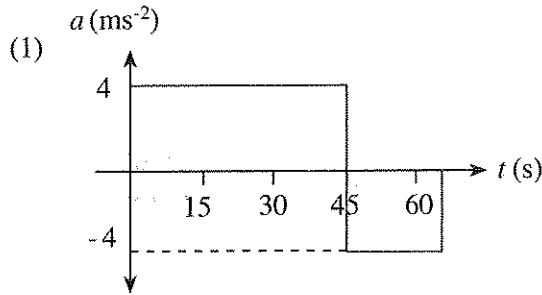

22. The roof truss shown in the figure is used to support roof loadings, W_1, W_2, W_3, W_4 and W_5 . In order to reduce central deflection due to roof loading, following suggestions have been proposed.

- A - Add more diagonal members
- B - Remove few diagonal members
- C - Increase section areas of lower and bottom chord members
- D - Connections are welded again.

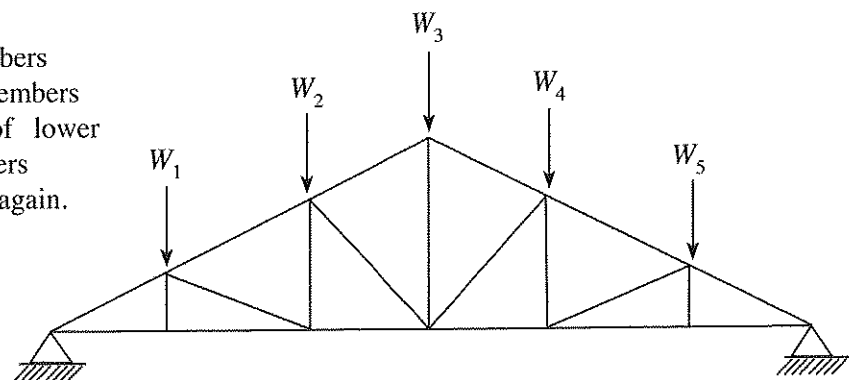

Which of the above suggestions are correct?

- (1) A and B only.
- (2) A and C only.
- (3) A and D only.
- (4) B and C only.
- (5) B and D only.

[See page six

Department of Examinations, Sri Lanka.

23. A hollow cement block is subjected to 10 kN load as shown in the figure. Axial Compressive stress applied on the block is
- (1) 33 kPa. (2) 50 kPa. (3) 0.33 MPa.
 (4) 0.5 MPa. (5) 5 MPa.

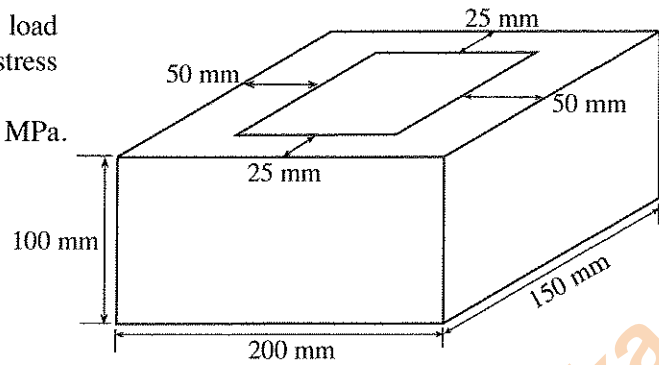

24. 600 kg weight is lifted through the portable jack as shown in the figure. The Force applied at the arm AB is
- (1) 300 kg. (2) 450 kg. (3) 600 kg.
 (4) 1000 kg. (5) 8000 kg.

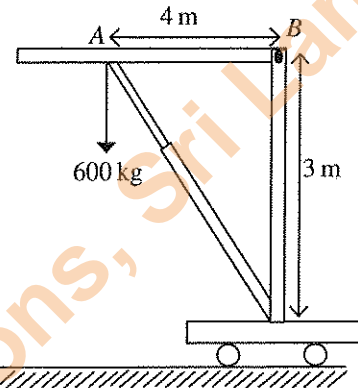

25. Which of the following skills can be observed in an efficient street-side cobbler, who mends footwear?
- A - Passion to serve customers
 B - Strong personal skills.
 C - Creativity.
 D - Competitiveness.
- (1) A, B and C only. (2) A, B and D only. (3) A, C and D only.
 (4) B, C and D only. (5) All A, B, C and D.
26. When designing a simply supported reinforced concrete beam bearing a uniformly distributed load, which one of the following aspects is **not** considered?
- (1) Material used in the beam.
 (2) Deflection of the beam under load.
 (3) Bearing stresses at lateral supports.
 (4) Buckling of the beam under the load.
 (5) Shear stresses carried by the beam.

27. Figure shows the stress-strain behaviour observed, when a cylindrical specimen of a normal weight concrete is tested.

- A - The maximum compressive stress is achieved approximately at a strain value of 0.3%.
 B - The characteristic strength of this concrete can be 30 N/mm².
 C - Its initial Young's modulus is around 23 MPa.
 D - Concrete shows a ductile stress-strain behaviour.

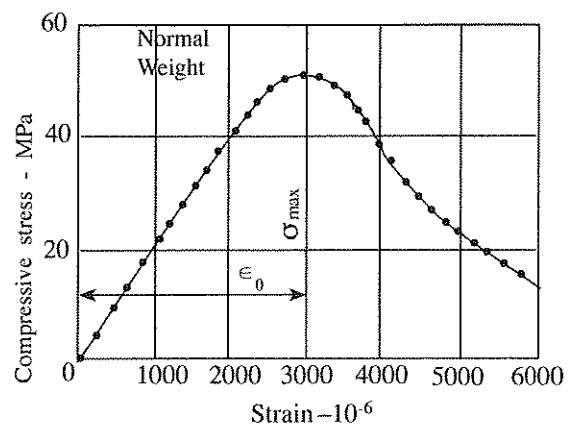

According to the figure given, which of the above statements are true?

- (1) A, B and C only. (2) A, B and D only. (3) A, C and D only.
 (4) B, C and D only. (5) All A, B, C and D.

28. Consider the following statements on waste management.

- A - Sorting and separation at source to make disposal economically viable.
- B - Reduction in biological waste through recycling and resource recovery before disposal.
- C - Landfilling for non-biodegradable, inert, and non-recyclable waste.
- D - Incineration that does not yield harmful or toxic gases is considered, when landfilling is not a viable option.

Which of the above are recommended by the Central Environmental Authority as good practices in solid waste management?

- (1) A, B and C only. (2) A, B and D only. (3) A, C and D only.
(4) B, C and D only. (5) All A, B, C and D.

29. Consider the following statements on surveying.

- A - Open traverse surveying and close traverse surveying are the two main types.
- B - Tilting levels are sometimes used in traverse surveying.
- C - The Chain is not used in traverse surveying.
- D - The steel band tape is used to take offset measurements.

Which of the above statements are true about traverse surveying?

- (1) A, B and C only. (2) A, B and D only. (3) A, C and D only.
(4) B, C and D only. (5) All A, B, C and D.

30. Consider the following statements on pipes used in households.

- A - A shower head is connected using a faucet elbow.
- B - A reducing socket is used when connecting two equal diameter pipes.
- C - A valve that regulates water flow is connected to two valve sockets.
- D - The main line that supplies pipe borne water to households is a 0.75-inch pipe.

Which of the above statements are true about PVC fittings?

- (1) A, B and C only. (2) A, B and D only. (3) A, C and D only.
(4) B, C and D only. (5) All A, B, C and D.

31. When joining a copper pipe by soldering, the heat applied to the pipe causes the solder to spread evenly within the joint, and this effect is termed

- (1) conduction. (2) convection. (3) radiation. (4) diffusion. (5) capillary action.

32. What is the option that gives respectively, the three types of most appropriate mortise and tenon joints for joining top rail, middle rail and bottom rail of a door sash to the stile?

	Top rail	Middle rail	Bottom rail
(1)	Double tenon	Haunched mortise and tenon	Haunched double tenon
(2)	Haunched mortise and tenon	Double tenon	Haunched double tenon
(3)	Haunched mortise and tenon	Haunched double tenon	Double tenon
(4)	Haunched double tenon	Haunched mortise and tenon	Double tenon
(5)	Double tenon	Haunched double tenon	Haunched mortise and tenon

33. Following are some of the waste management methods that could be adopted to protect the Environment.

- A - power generation through burning
- B - recycling of waste
- C - reduce generation of waste
- D - reuse of waste
- E - land filling with waste

The order of preference from the best to the worst method of waste management of the above is

- (1) A,C,D,B and E. (2) A,C,E,B and D. (3) B,C,E,A and D.
(4) C,B,D,E and A. (5) C,D,B,A and E.

34. Worksite hazards can be broadly classified under 5 major categories. Under which category would an electrocution of a site worker be classified?
- (1) Physical hazard (2) Chemical hazard (3) Biological hazard
(4) Ergonomic hazard (5) Psychological hazard
35. In quantity surveying, a query sheet is prepared by the quantity surveyor for the purpose of
- (1) ascertaining market prices of construction materials.
(2) deciding the commencement and completion dates of a construction project.
(3) ascertaining unclear details of drawings provided for quantity surveying.
(4) calculating total labour cost of the project.
(5) calculating total material cost of the project.
36. The most important information to be included in a bar chart to demonstrate progress of work at a construction site is
- (1) method of measurement. (2) interim payments. (3) plant requirements.
(4) material requirements. (5) work durations.
37. In a water supply system, a stop valve is used to
- (1) meter the flow of water.
(2) prevent back-flow of water.
(3) isolate the system from the supply.
(4) prevent overflowing.
(5) facilitate regular cleaning.
38. Out of the following sheet material, which one is **not** a timber-based product?
- (1) Plywood board (2) Plaster board (3) Hard board
(4) Block board (5) Particle board
39. Consider the following statements on building lines used in constructing buildings.
- A - To facilitate future widening of roads
B - To keep away noise and dust of the street
C - To prevent formation of blind corners
D - To reduce the buildable land extent of the property
- Which of the above statements are true in relation to the purpose of defining a building line in building by-laws?
- (1) A, B and C only. (2) A, B and D only. (3) A, C and D only.
(4) B, C and D only. (5) All A, B, C and D.
40. Consider the following statements.
- A - The surface which is parallel to the mean spheroid surface of the earth is known as the Level Surface.
B - The surface which is tangential to the level surface is horizontal
C - The direction indicated by the direction of gravity is known as the vertical line.
D - A surface over which water will not flow is a level surface.
- Which of the above statements are true with regard to levelling?
- (1) A and C only. (2) B and C only. (3) A, B and C only.
(4) A, C and D only. (5) All A, B, C and D.
41. Consider the following valves/taps related to a water supply system?
- A - Gate Valve
B - Float valve
C - Non-return valve
D - Bib Tap
- Out of the above, what are the valves/taps that could be used to allow, stop, reduce and increase water flow?
- (1) A and B only. (2) A and C only. (3) A and D only.
(4) B and C only. (5) C and D only.

42. Consider the following statements.

- A - The survey plan number
- B - Boundaries, scale, location of the land
- C - Name of owner, name of the head of the local government authority
- D - Extent of land, north direction
- E - Surveyor's name, his signature and date of surveyed

Which of the above statements give the essential information stated in a survey plan?

- (1) A, B, C and D only. (2) A, B, C and E only. (3) A, B, D and E only.
 (4) A, C, D and E only. (5) All A, B, C, D and E.

43. The documents used by a quantity surveyor are as follows.

- A - Drawings
- B - Measurement sheets
- C - Query sheets
- D - Bill of quantities

Out of above documents, documents that are required to start 'taking off' of quantities are

- (1) A, B and C only. (2) A, B and D only. (3) A, C and D only.
 (4) B, C and D only. (5) All A, B, C and D.

44. Consider the following statements.

- A - Mezzanine floor is the additional intermediate floor between two regular floor levels.
- B - Water closet (W.C.) is the place used for washing purposes.
- C - Bathroom is privy with arrangement for flushing the pan with water.
- D - Pantry is the room generally provided adjacent to dining room for keeping cooked food.

The true statements out of the above are

- (1) A and C only. (2) A and D only. (3) B and C only.
 (4) B and D only. (5) All A, B, C and D.

45. In glazed doors with a timber frame, the glass is fixed to the timber frame by

- (1) wood screws fixed to frame.
- (2) gluing to timber frame.
- (3) inserting it into grooves in timber frame.
- (4) rebates of the timber frame using glazing rods.
- (5) rebates of the timber frame using wire nails.

46. Out of the following steel bars, which one would be the most suitable in reinforced cement concrete (RCC) beams?

- (1) Plain round bars (2) Ribbed bars
- (3) Tor steel bars (4) Quenched and self-tempered (QST) bars
- (5) Steel fabric

47. Water treatment sedimentation is done

- (1) before filtration. (2) after filtration.
- (3) simultaneously with filtration. (4) before chlorination.
- (5) along with chlorination.

48. A reverse circular curve is to be set out during a road construction. Chainage of Point A is 989.25 m. Curves BC and CD have radius 150 m and 200 m, respectively. AB and DE sections consist of straight sections of 100 m each. Chainage of F is

- (1) 1628.75 m.
- (2) 1638.75 m.
- (3) 1658.75 m.
- (4) 1739.03 m.
- (5) 1758.75 m.

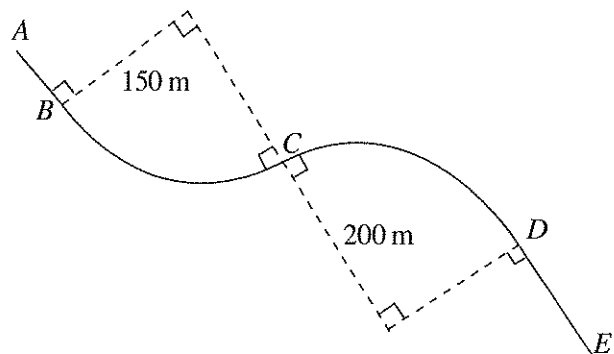

49. Consider the following statements.

- A - Flexible pavements give increased comfort compared to rigid pavements.
- B - Most road pavements of Sri Lanka are rigid pavements.
- C - By increasing the thickness of the wearing course, rigid pavements can be constructed.
- D - Rigid pavements are more economical since it's maintenance cost is low.

Which of the above statements are true about road pavements?

- (1) A and B only.
- (2) A and C only.
- (3) A and D only.
- (4) B and C only.
- (5) C and D only.

50. Consider the following statements.

- A - A wing wall of a bridge abutment is used to reduce soil erosion.
- B - Any geometrical shape can be used in bridge piers.
- C - Polymer materials can be used for expansion joints provided in the bridge deck.
- D - Steel is not used as a bridge bearing material.

Which of the above statements are true about bridges?

- (1) A, B and C only.
- (2) A, B and D only.
- (3) A, C and D only.
- (4) B, C and D only.
- (5) All A, B, C and D.

* * *

සියලු ම හිමිකම් ඇවිරිණි / முழுப் பதிப்புரிமையுடையது / All Rights Reserved

වෙ/පැරණි නිර්දේශය - புதிய/பழைய பாடத்திட்டம் - New/Old Syllabus

NEW/OLD

ශ්‍රී ලංකා විභාග දෙපාර්තමේන්තුව ශ්‍රී ලංකා විභාග දෙපාර්තමේන්තුව ශ්‍රී ලංකා විභාග දෙපාර්තමේන්තුව ශ්‍රී ලංකා විභාග දෙපාර්තමේන්තුව ශ්‍රී ලංකා විභාග දෙපාර්තමේන්තුව
 இலங்கைப் பரீட்சைத் திணைக்களம் இலங்கைப் பரීட்சைத் திணைக்களம் இலங்கைப் பரීட்சைத் திணைக்களம் இலங்கைப் பரීட்சைத் திணைக்களம் இலங்கைப் பரීட்சைத் திணைக்களம்
 Department of Examinations, Sri Lanka Department of Examinations, Sri Lanka Department of Examinations, Sri Lanka Department of Examinations, Sri Lanka Department of Examinations, Sri Lanka

අධ්‍යයන පොදු සහතික පත්‍ර (උසස් පෙළ) විභාගය, 2019 අගෝස්තු
 கல்விப் பொதுத் தராதரப் பத்திர (உயர் தர)ப் பரீட்சை, 2019 ஓகஸ்ட்
 General Certificate of Education (Adv. Level) Examination, August 2019

සිවිල් තාක්ෂණවේදය II
 குடிசார்த் தொழினுட்பவியல் II
 Civil Technology II

14 E II

17.08.2019 / 1300 - 1640

පැය තුනයි
 மூன்று மணித்தியாலம்
 Three hours

අමතර කියවීමේ කාලය - මිනිත්තු 10 යි
 மேலதிக வாசிப்பு நேரம் - 10 நிமிடங்கள்
 Additional Reading Time - 10 minutes

Use additional reading time to go through the question paper, select the questions and decide on the questions that you give priority in answering.

Index No. :

Important :

- * This question paper consists of **II** pages.
- * This question paper comprises **Parts A, B and C**. The time allotted for **all parts** is **three hours**. (Use of calculators is **not** allowed.)

Part A - Structured Essay (08 pages)

- * Answer **all** the questions on this paper itself.
- * Write your answers in the space provided for each question. Note that the space provided is sufficient for your answers and that extensive answers are not expected.

Part B and C - Essay (03 pages)

- * Select minimum of **two** questions from each of the parts **B** and **C** and answer **four** questions only. Use the papers supplied for this purpose. At the end of the time allotted for this paper, tie the **three parts** together so that **Part A** is on the top of **Part B** and **C** before handing over to the supervisor.
- * You are permitted to remove only **Parts B and C** of the question paper from the Examination Hall.

For Examiner's Use Only

Part	Q. No.	Marks
A	1	
	2	
	3	
	4	
B	1	
	2	
	3	
C	4	
	5	
	6	
Total		

Total	
In Numbers	
In Words	

Code Numbers	
Marking Examiner 1	
Marking Examiner 2	
Checked by	
Supervised by	

[see page two]

PART A – Structured Essay
 Answer **all four** questions on this paper itself.
 (Each question carries **10** marks)

Do not
 write
 in this
 column

1. An isometric view of a machine component is shown in the figure. Machine component is symmetric along the vertical plane passing through X-X. Assuming any missing dimensions, draw the following views to a suitable scale using first angle projection principle. Show all relevant dimensions in the sketches. Use the graph sheets given on page 3 and 4 to answer the questions. (All dimensions are in mm.)

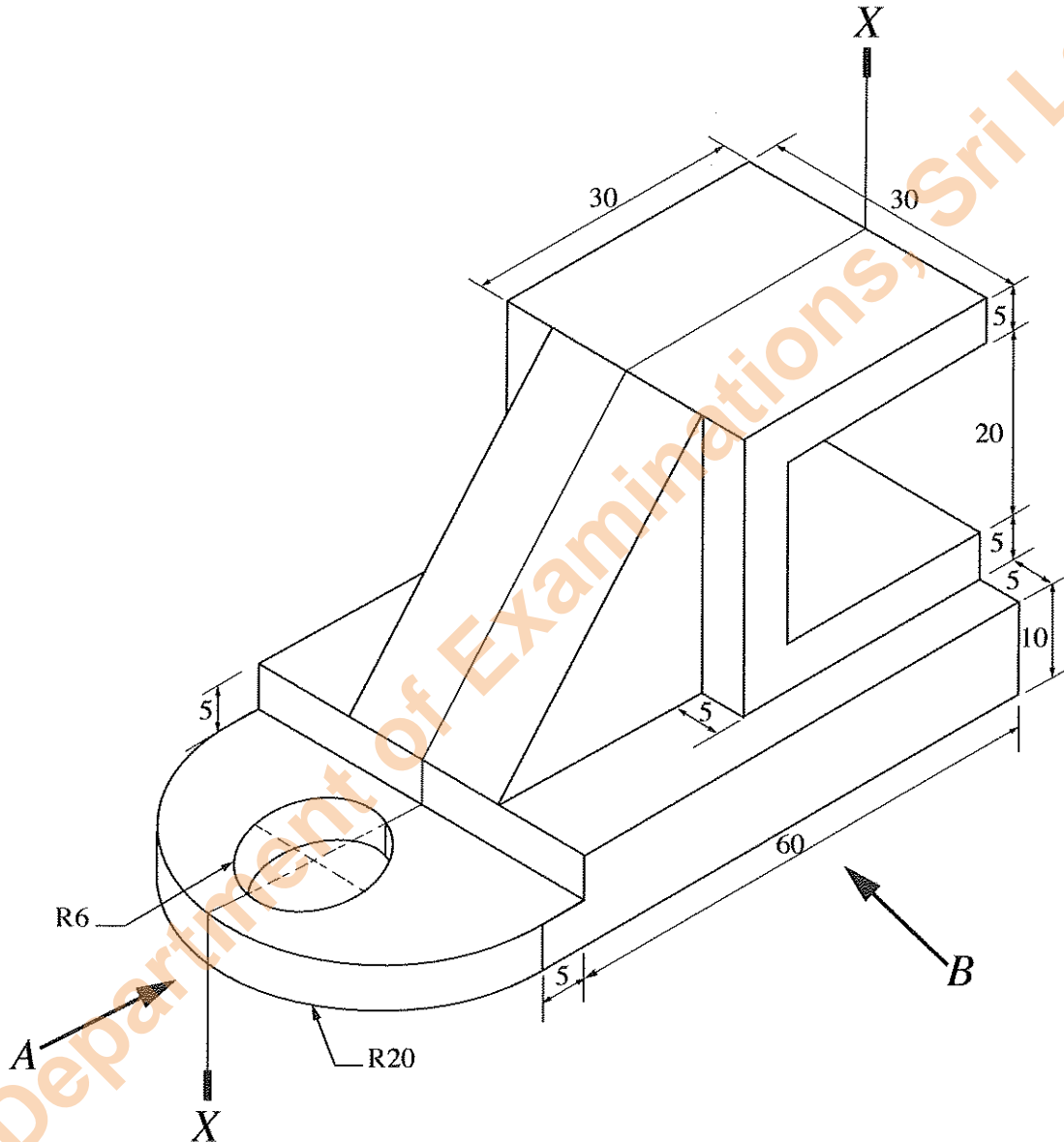

- (i) Front elevation seen through direction A.
 (ii) End elevation seen through direction B.
 (iii) Plan.

[see page three

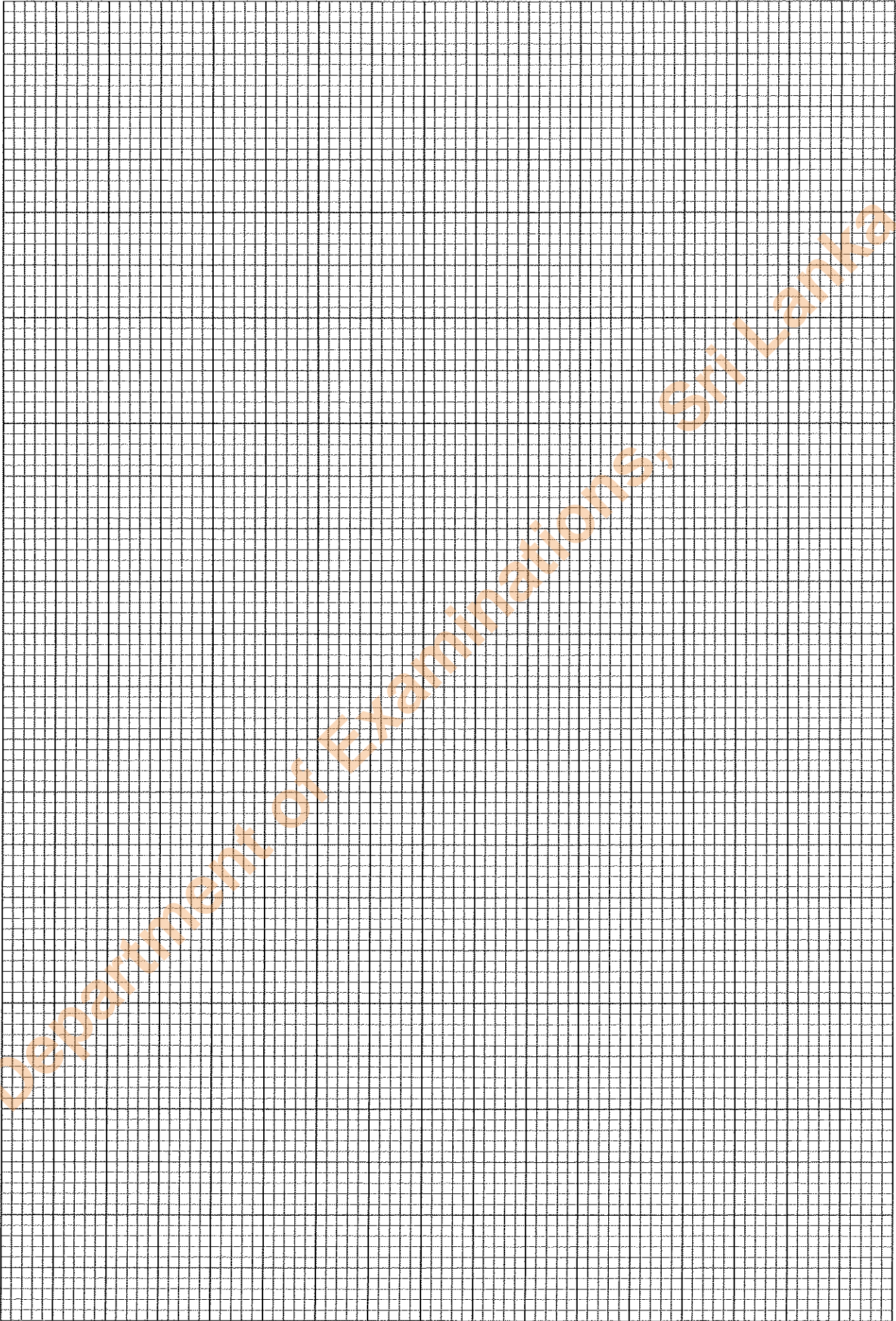

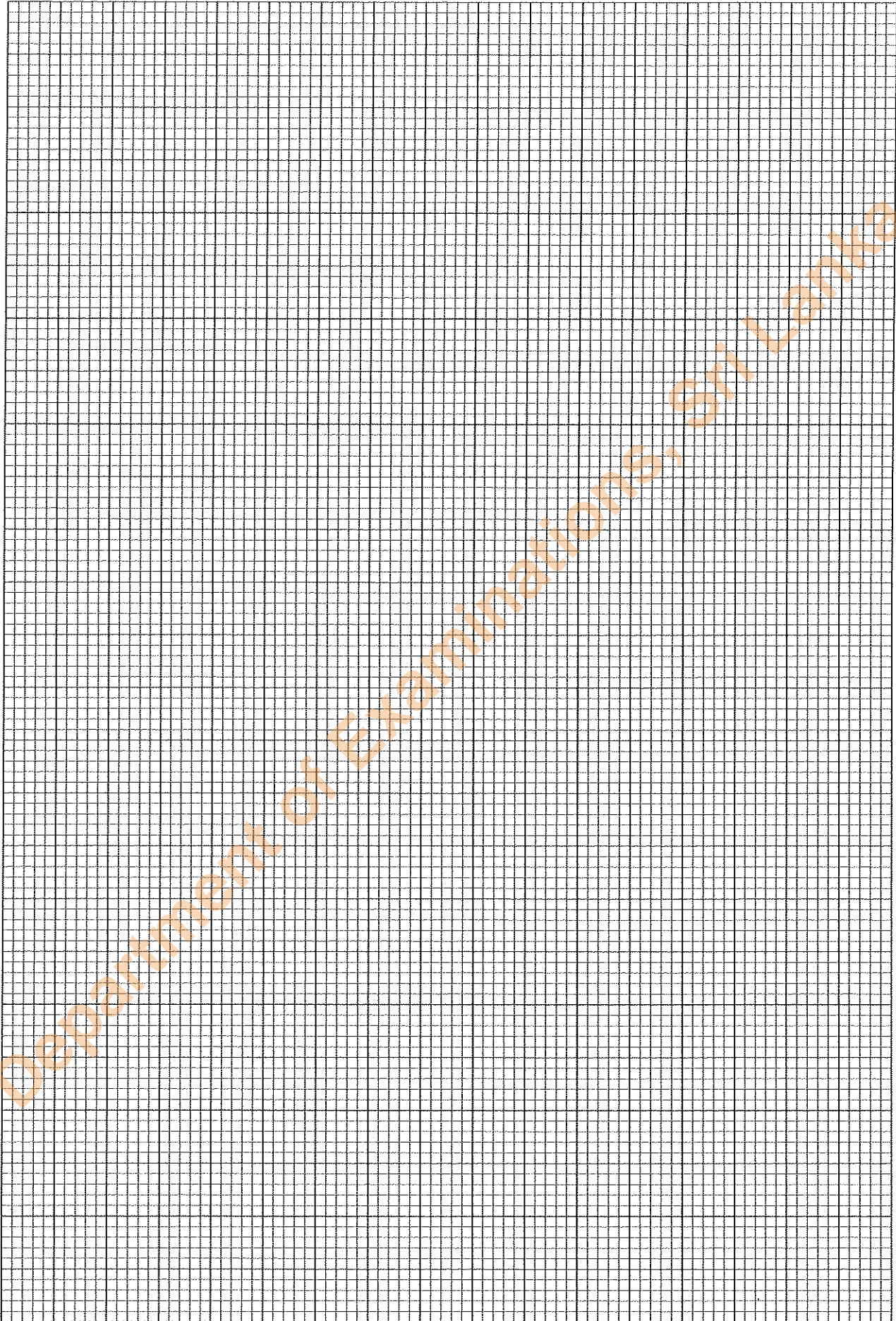

[see page five

Department of Examinations, Sri Lanka

Department of Examinations, Sri Lanka.

Do not write in this column

2. A group of teachers from City School are planning to have an interactive classroom with following special functions.

They have installed an interactive multimedia projector. Teacher can write on the board by using a digital pen and content can be stored in the memory. Digital pen is not an ink pen. It will show in display in digital form. Content can be transferred to the computer connected at the teacher's desktop. Further, this can be used to comment on top of other content such as power point presentations, word documents, web pages etc.

Furthermore, they have planned to use this interactive classroom for getting the service of university lecturers using video conferencing facilities. Students are given facilities to interact with the lecturer.

Assume you are assigned to give the Information Technology support for the team.

(a) State **three** software required for the laptop at the teacher's desk in addition to specific software and drivers of interactive display.

- (1)
- (2)
- (3)

(b) State **three** types of additional hardware required for the interactive classroom in addition to computers or laptops.

- (1)
- (2)
- (3)

(c) Assume all student are using their laptops. State **two** options for networking student laptops and connecting them with the teacher's laptop.

- (1)
- (2)

(d) Students are requested to submit their classroom assignments online. State **one** facility suitable for this purpose.

.....
.....

(e) In group activities, students are requested to collaboratively develop group reports. State **one** facility suitable for this purpose.

.....
.....



Department of Examinations, Sri Lanka.

Do not write in this column

3. (a) Figure shows the configuration of a 13A plug. Name the different components A, B, C, D, E, F as indicated in the figure.

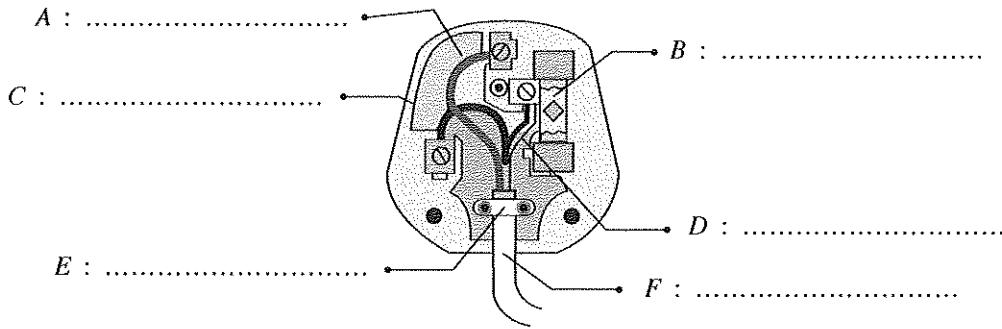

State the purposes of the each component, named A - F in the above figure.

- A :
- B :
- C :
- D :
- E :
- F :

(b) Discuss why Sri Lanka has adopted the 13A square-pin plug and the socket as the standard type, in comparison to the popular 5A round-pin plug and the socket.

.....

(c) Explain how the Miniature Circuit Breakers (MCBs) are used. Sketch to show how these units are connected to the domestic electrical power supply system.

.....

Department of Examinations, Sri Lanka.

Do not write in this column

(d) Explain how a Residual Current Circuit Breaker (RCCB) is used. Sketch to show how this unit is connected to the domestic electrical power supply system.

.....

.....

.....

.....

.....

.....

.....

.....



4. When designing a building, the current practice is to use a two-stack system where gray water and black water is transported to the soil separately.

(a) Draw a sketch to show different components of the two-stack system.

(b) List the advantages and limitations of using two stacks.

.....

.....

.....

.....

Department of Examinations, Sri Lanka.

- Figure shows a two-chamber septic tank commonly used in domestic waste disposal systems. To answer questions (c)-(f) use this figure.

Do not write in this column

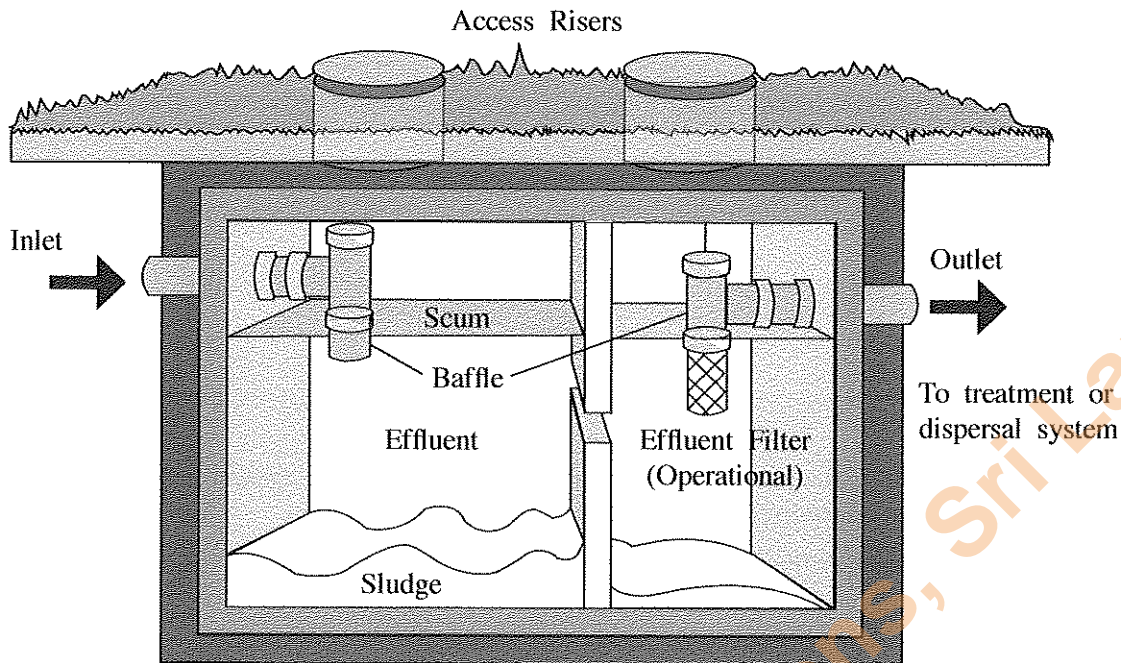

(c) Explain briefly the treatment process of the above septic-tank system.

.....

.....

.....

.....

.....

.....

.....

.....

.....

(d) Explain why the outlet pipe is located below the level of the inlet pipe.

.....

.....

(e) Explain what the scum consists of and what the sludge consists of.

.....

.....

.....

(f) Explain why this unit is designed as a 'sealed' unit.

.....

.....

.....



[see page nine

Department of Examinations, Sri Lanka.

Before buying PHEV, the average energy consumption was 200 units per month. Domestic customer Tariff for electricity is as follows.

Monthly Consumption (kWh)	Unit charge (Rs.)
0 – 60	8
61 – 90	10
91 – 120	28
121 – 180	32
>180	45

Fixed charge for a customer above 180 units usage per month is Rs. 540.00.

- What is total energy generated by the 2kW PV roof top per month?
 - What is the total energy consumed by the 'PHEV' for charging per month?
 - What is the total income from selling energy to Ceylon Electricity Board?
 - What is the Net-Electricity Bill per month?
 - Assuming the Petrol cost is Rs. 150.00 and from one litre the vehicle can run 10km, what is your opinion regarding the usage of charging PHEV using main supply?
3. World elderly population increase rapidly. However, there is a problem of availability of skilled care givers and new generation is busy with their daily activities. Technological solutions are being developed to address this problem. The elderly people prefer to be in their homes rather than living in special elderly care homes.
- Discuss **three** technological innovations that can be used to improve physical and mental well-being of the elderly.
 - Select **one** technological innovation mentioned in (a) above and explain how it can be used to keep elderly in their own homes rather than in a home for elders, taking into consideration the busy life style of the present generation.
 - Discuss **two** instances where technology can assist elderly people to attend to their daily activities independently.

Part C

4. The World Green Building Council defines a green building as a building, that in its design, construction or operation, reduces or eliminates negative impacts and can create positive impacts on our climate and the natural environment. Green buildings preserve precious natural resources and improve our quality of life (source: <http://www.worldgbc.org/what-green-building>).

It identifies the following as features that make a building green.

- Efficient use of energy, water and other resources
- Use of renewable energy such as solar energy
- Pollution and waste reduction measures and the enabling of re-use and recycling
- Good indoor environmental air quality
- Use of materials that are non-toxic, ethical and sustainable
- Consideration of the environment in design, construction and operation
- Consideration of the quality of life of occupants in design, construction and operation
- A design that enables adaptation to a changing environment

Assume that you are given the task to recommend features to be included in the proposed three-storeyed science-stream school building, to be classified as a green building. Write an essay while addressing the following.

- Introduce the building and its surrounding highlighting on important aspects related to greening.
- Describe how you would ensure that the above-mentioned features are incorporated during its design and construction stages and during its use.

5. (a) When preparing the unit rate of a reinforced cement concrete floor-slab, discuss the cost-elements you would consider. Also describe the aspects of each cost element.
- (b) Differentiate between net unit rate and gross unit rate of a work item.
- (c) Following quantities of material and labour are required to build 1 m³ of brickwork with 1:5 cement mortar. Calculate the net unit rate and gross unit rate of brickwork based on the below-mentioned quantities. State reasonable market prices for material and labour you would use in this computation. State any other assumptions you have made.
- Bricks - 520 Nos.
 - Cement - 0.85 bags
 - Sand - 0.15 m³
 - Mason - 01 day
 - Helper - 02 days
6. A residential two-storeyed building has to be set out in a certain land plot adjacent to a main road as shown. The distance to be kept from road center line is already known.

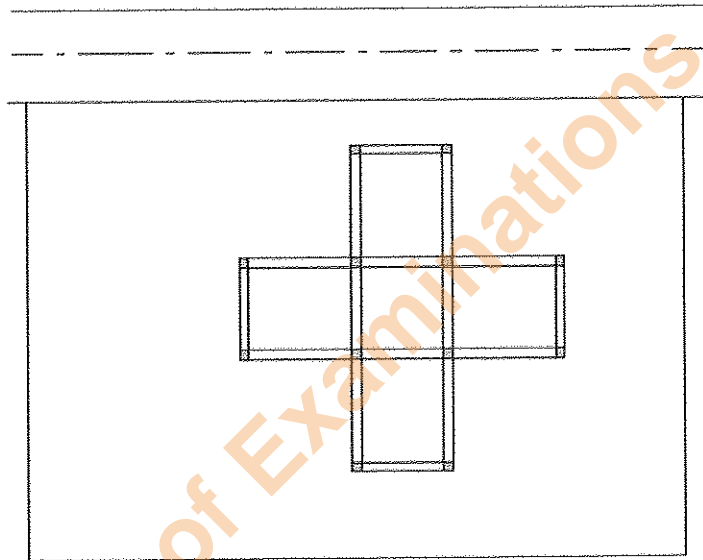

- (a) List the instruments and items needed for setting out the building.
- (b) Describe how setting out is performed if the instruments and items listed in section (a) above is provided.
- (c) Describe how to check the orthogonal nature of setting out lines using band tape only.
- (d) Explain how you level a Theodolite with clear sketches.

* * *

Department of Examinations, Sri Lanka.

Department of Examinations, Sri Lanka.