

5. Show that $\lim_{x \rightarrow 3} \frac{\sqrt{x-2}-1}{\sin(\pi(x-3))} = \frac{1}{2\pi}$.

6. The region enclosed by the curves $y = \sqrt{\frac{x+1}{x^2+1}}$, $x=0$, $x=1$ and $y=0$ is rotated about the x -axis through 2π radians. Show that the volume of the solid thus generated is $\frac{\pi}{4}(\pi + \ln 4)$.

නව නිර්දේශය/புதிய பாடத்திட்டம்/New Syllabus

ශ්‍රී ලංකා විභාග දෙපාර්තමේන්තුව ශ්‍රී ලංකා විභාග දෙපාර්තමේන්තුව ශ්‍රී ලංකා විභාග දෙපාර්තමේන්තුව ශ්‍රී ලංකා විභාග දෙපාර්තමේන්තුව ශ්‍රී ලංකා විභාග දෙපාර්තමේන්තුව
 திணைக்களம் இலங்கைப் பரீட்சைத் திணைக்களம் இலங்கைப் பரීட்சைத் திணைக்களம் இலங்கைப் பரීட்சைத் திணைக்களம் இலங்கைப் பரීட்சைத் திணைக்களம்
 Department of Examinations, Sri Lanka Department of Examinations, Sri Lanka Department of Examinations, Sri Lanka Department of Examinations, Sri Lanka Department of Examinations, Sri Lanka
 இலங்கைப் பரීட்சைத் திணைக்களம் இலங்கைப் பரීட்சைத் திணைக்களம் இலங்கைப் பரීட்சைத் திணைக்களம் இலங்கைப் பரීட்சைத் திணைக்களம் இலங்கைப் பரීட்சைத் திணைக்களம்

NEW

අධ්‍යයන පොදු සහතික පත්‍ර (උසස් පෙළ) විභාගය, 2019 අගෝස්තු
 கல்விப் பொதுத் தராதரப் பத்திர (உயர் தர)ப் பரீட்சை, 2019 ஆகஸ்ட்
 General Certificate of Education (Adv. Level) Examination, August 2019

සංයුක්ත ගණිතය I
 இணைந்த கணிதம் I
 Combined Mathematics I

10 E I

Part B

* Answer five questions only.

11. (a) Let $p \in \mathbb{R}$ and $0 < p \leq 1$. Show that 1 is **not** a root of the equation $p^2x^2 + 2x + p = 0$.

Let α and β be the roots of this equation. Show that α and β are both real.

Write down $\alpha + \beta$ and $\alpha\beta$ in terms of p , and show that

$$\frac{1}{(\alpha - 1)} \cdot \frac{1}{(\beta - 1)} = \frac{p^2}{p^2 + p + 2}.$$

Show also that the quadratic equation whose roots are $\frac{\alpha}{\alpha - 1}$ and $\frac{\beta}{\beta - 1}$ is given by $(p^2 + p + 2)x^2 - 2(p + 1)x + p = 0$ and that both of these roots are positive.

(b) Let c and d be two **non-zero** real numbers and let $f(x) = x^3 + 2x^2 - dx + cd$. It is given that $(x - c)$ is a factor of $f(x)$ and that the remainder when $f(x)$ is divided by $(x - d)$ is cd . Find the values of c and d .

For these values of c and d , find the remainder when $f(x)$ is divided by $(x + 2)^2$.

12. (a) Let P_1 and P_2 be the two sets given by $\{A, B, C, D, E, 1, 2, 3, 4\}$ and $\{F, G, H, I, J, 5, 6, 7, 8\}$ respectively. It is required to form a password consisting of 6 elements taken from $P_1 \cup P_2$ of which 3 are different letters and 3 are different digits. In each of the following cases, find the number of different such passwords that can be formed:

(i) all 6 elements are chosen only from P_1 ,

(ii) 3 elements are chosen from P_1 and the other 3 elements from P_2 .

(b) Let $U_r = \frac{1}{r(r+1)(r+3)(r+4)}$ and $V_r = \frac{1}{r(r+1)(r+2)}$ for $r \in \mathbb{Z}^+$.

Show that $V_r - V_{r+2} = 6U_r$ for $r \in \mathbb{Z}^+$.

Hence, show that $\sum_{r=1}^n U_r = \frac{5}{144} - \frac{(2n+5)}{6(n+1)(n+2)(n+3)(n+4)}$ for $n \in \mathbb{Z}^+$.

Let $W_r = U_{2r-1} + U_{2r}$ for $r \in \mathbb{Z}^+$.

Deduce that $\sum_{r=1}^n W_r = \frac{5}{144} - \frac{(4n+5)}{24(n+1)(n+2)(2n+1)(2n+3)}$ for $n \in \mathbb{Z}^+$.

Hence, show that the infinite series $\sum_{r=1}^{\infty} W_r$ is convergent and find its sum.

13. (a) Let $A = \begin{pmatrix} a & 0 & -1 \\ 0 & -1 & 0 \end{pmatrix}$, $B = \begin{pmatrix} 2 & 1 & 3 \\ 1 & -a & 4 \end{pmatrix}$ and $C = \begin{pmatrix} b & -2 \\ -1 & b+1 \end{pmatrix}$ be matrices such that

$$AB^T = C, \text{ where } a, b \in \mathbb{R}.$$

Show that $a = 2$ and $b = 1$.

Show also that, C^{-1} does not exist.

Let $P = \frac{1}{2}(C - 2I)$. Write down P^{-1} and find the matrix Q such that $2P(Q+3I) = P - I$, where I is the identity matrix of order 2.

(b) Let $z, z_1, z_2 \in \mathbb{C}$.

Show that (i) $\operatorname{Re} z \leq |z|$, and

$$(ii) \left| \frac{z_1}{z_2} \right| = \frac{|z_1|}{|z_2|} \text{ for } z_2 \neq 0.$$

Deduce that $\operatorname{Re} \left(\frac{z_1}{z_1 + z_2} \right) \leq \frac{|z_1|}{|z_1 + z_2|}$ for $z_1 + z_2 \neq 0$.

Verify that $\operatorname{Re} \left(\frac{z_1}{z_1 + z_2} \right) + \operatorname{Re} \left(\frac{z_2}{z_1 + z_2} \right) = 1$ for $z_1 + z_2 \neq 0$,

and show that $|z_1 + z_2| \leq |z_1| + |z_2|$ for $z_1, z_2 \in \mathbb{C}$.

(c) Let $\omega = \frac{1}{2}(1 - \sqrt{3}i)$.

Express $1 + \omega$ in the form $r(\cos \theta + i \sin \theta)$; where $r(>0)$ and $\theta \left(-\frac{\pi}{2} < \theta < \frac{\pi}{2} \right)$ are constants to be determined.

Using De Moivre's theorem, show that $(1 + \omega)^{10} + (1 + \bar{\omega})^{10} = 243$.

14. (a) Let $f(x) = \frac{9(x^2 - 4x - 1)}{(x - 3)^3}$ for $x \neq 3$.

Show that $f'(x)$, the derivative of $f(x)$, is given by $f'(x) = -\frac{9(x+3)(x-5)}{(x-3)^4}$ for $x \neq 3$.

Sketch the graph of $y=f(x)$ indicating the asymptotes, y -intercept and the turning points.

It is given that $f''(x) = \frac{18(x^2 - 33)}{(x-3)^5}$ for $x \neq 3$.

Find the x -coordinates of the points of inflection of the graph of $y=f(x)$.

(b) The adjoining figure shows a basin in the form of a frustum of a right circular cone with a bottom. The slant length of the basin is 30 cm and the radius of the upper circular edge is twice the radius of the bottom. Let the radius of the bottom be r cm.

Show that the volume V cm³ of the basin is given by

$$V = \frac{7}{3} \pi r^2 \sqrt{900 - r^2} \text{ for } 0 < r < 30.$$

Find the value of r such that volume of the basin is maximum.

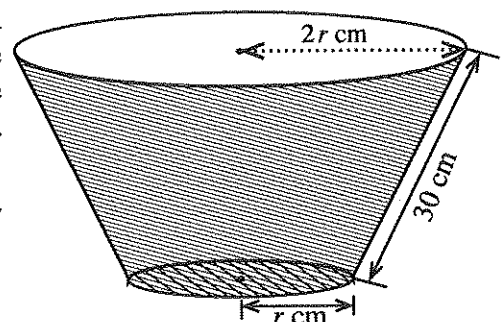

[see page nine]

15. (a) Using the substitution $x=2\sin^2\theta+3$ for $0\leq\theta\leq\frac{\pi}{4}$, evaluate $\int_3^4\sqrt{\frac{x-3}{5-x}}dx$.

(b) Using partial fractions, find $\int\frac{1}{(x-1)(x-2)}dx$.

$$\text{Let } f(t) = \int_3^t \frac{1}{(x-1)(x-2)} dx \text{ for } t > 2.$$

Deduce that $f(t) = \ln(t-2) - \ln(t-1) + \ln 2$ for $t > 2$.

Using integration by parts, find $\int \ln(x-k) dx$, where k is a real constant.

Hence, find $\int f(t) dt$.

(c) Using the formula $\int_a^b f(x) dx = \int_a^b f(a+b-x) dx$, where a and b are constants,

$$\text{show that } \int_{-\pi}^{\pi} \frac{\cos^2 x}{1+e^x} dx = \int_{-\pi}^{\pi} \frac{e^x \cos^2 x}{1+e^x} dx.$$

Hence, find the value of $\int_{-\pi}^{\pi} \frac{\cos^2 x}{1+e^x} dx$.

16. Write down the coordinates of the point of intersection A of the straight lines $12x-5y-7=0$ and $y=1$.

Let l be the bisector of the acute angle formed by these lines. Find the equation of the straight line l .

Let P be a point on l . Show that the coordinates of P can be written as $(3\lambda+1, 2\lambda+1)$, where $\lambda \in \mathbb{R}$.

Let $B \equiv (6, 0)$. Show that the equation of the circle with the points B and P as ends of a diameter can be written as $S + \lambda U = 0$, where $S \equiv x^2 + y^2 - 7x - y + 6$ and $U \equiv -3x - 2y + 18$.

Deduce that $S=0$ is the equation of the circle with AB as a diameter.

Show that $U=0$ is the equation of the straight line through B , perpendicular to l .

Find the coordinates of the fixed point which is distinct from B , and lying on the circles with the equation $S + \lambda U = 0$ for all $\lambda \in \mathbb{R}$.

Find the value of λ such that the circle given by $S=0$ is orthogonal to the circle given by $S + \lambda U = 0$.

17. (a) Write down $\sin(A+B)$ in terms of $\sin A$, $\cos A$, $\sin B$ and $\cos B$, and obtain a similar expression for $\sin(A-B)$.

Deduce that

$$2 \sin A \cos B = \sin(A+B) + \sin(A-B) \text{ and}$$

$$2 \cos A \sin B = \sin(A+B) - \sin(A-B).$$

Hence, solve $2 \sin 3\theta \cos 2\theta = \sin 7\theta$ for $0 < \theta < \frac{\pi}{2}$.

- (b) In a triangle ABC , the point D lies on AC such that $BD = DC$ and $AD = BC$. Let $\hat{BAC} = \alpha$ and $\hat{ACB} = \beta$. Using the Sine Rule for suitable triangles, show that $2 \sin \alpha \cos \beta = \sin(\alpha + 2\beta)$.

If $\alpha : \beta = 3 : 2$, using the last result in (a) above, show that $\alpha = \frac{\pi}{6}$.

- (c) Solve $2 \tan^{-1} x + \tan^{-1}(x+1) = \frac{\pi}{2}$. **Hence**, show that $\cos\left(\frac{\pi}{4} - \frac{1}{2} \tan^{-1}\left(\frac{4}{3}\right)\right) = \frac{3}{\sqrt{10}}$.

Department of Examinations, Sri Lanka.

AL/2019/10/E-II(NEW)

கிடைக்கக்கூடிய அனைத்து உரிமைகளும் பாதுகாக்கப்பட்டன/All Rights Reserved

புதிதாக அறிமுகப்படுத்தப்பட்ட பாடத்திட்டம்/புதிய பாடத்திட்டம்/New Syllabus

NEW

ශ්‍රී ලංකා විභාග දෙපාර්තමේන්තුව ශ්‍රී ලංකා විභාග දෙපාර්තමේන්තුව ශ්‍රී ලංකා විභාග දෙපාර්තමේන්තුව ශ්‍රී ලංකා විභාග දෙපාර්තමේන්තුව ශ්‍රී ලංකා විභාග දෙපාර්තමේන්තුව
 திணைக்களம் இலங்கைப் பரீட்சைத் திணைக்களம் இலங்கைப் பரීட்சைத் திணைக்களம் இலங்கைப் பரීட்சைத் திணைக்களம் இலங்கைப் பரීட்சைத் திணைக்களம்
 ශ්‍රී ලංකා විභාග දෙපාර්තමේන්තුව ශ්‍රී ලංකා විභාග දෙපාර්තමේන්තුව ශ්‍රී ලංකා විභාග දෙපාර්තමේන්තුව ශ්‍රී ලංකා විභාග දෙපාර්තමේන්තුව ශ්‍රී ලංකා විභාග දෙපාර්තමේන්තුව
 இலங்கைப் பரීட்சைத் திணைக்களம் இலங்கைப் பரීட்சைத் திணைக்களம் இலங்கைப் பரීட்சைத் திணைக்களம் இலங்கைப் பரීட்சைத் திணைக்களம் இலங்கைப் பரීட்சைத் திணைக்களம்
 Department of Examinations, Sri Lanka

අධ්‍යයන පොදු සහතික පත්‍ර (උසස් පෙළ) විභාගය, 2019 අගෝස්තු
 கல்விப் பொதுத் தராதரப் பத்திர (உயர் தர)ப் பரீட்சை, 2019 ஓகஸ்ட்
 General Certificate of Education (Adv. Level) Examination, August 2019

සංයුක්ත ගණිතය II
 இணைந்த கணிதம் II
Combined Mathematics II

10 E II

07.08.2019 / 0830 - 1140

පැය තුනයි
 மூன்று மணித்தியாலம்
Three hours

අමතර කියවීමේ කාලය - මිනිත්තු 10 යි
 மேலதிக வாசிப்பு நேரம் - 10 நிமிடங்கள்
Additional Reading Time - 10 minutes

Use **additional reading time** to go through the question paper, select the questions and decide on the questions that you give priority in answering.

Instructions:

Index Number

- * This question paper consists of two parts;
Part A (Questions 1–10) and **Part B** (Questions 11–17)
- * **Part A:**
 Answer **all** questions. Write your answers to each question in the space provided. You may use additional sheets if more space is needed.
- * **Part B:**
 Answer **five** questions only. Write your answers on the sheets provided.
- * At the end of the time allotted, tie the answer scripts of the two parts together so that **Part A** is on top of **Part B** and hand them over to the supervisor.
- * You are permitted to remove **only Part B** of the question paper from the Examination Hall.
- * In this question paper, g denotes the acceleration due to gravity.

For Examiners' Use only

(10) Combined Mathematics II		
Part	Question No.	Marks
A	1	
	2	
	3	
	4	
	5	
	6	
	7	
	8	
	9	
	10	
B	11	
	12	
	13	
	14	
	15	
	16	
	17	
	Total	

Total

In Numbers

In Words

Code Numbers

Marking Examiner

Checked by:

1

2

Supervised by:

3. In the figure, A , B and C are particles of masses m , m and M , respectively. The particles A and B are connected by a light inextensible string. The particle C , lying on a smooth horizontal table, is connected to B by another light inextensible string passing over a smooth small pulley fixed at the edge of the table. The particles and the strings all lie in the same vertical plane. The system is released from rest with the strings taut. Write down equations sufficient to determine the tension of the string joining A and B .

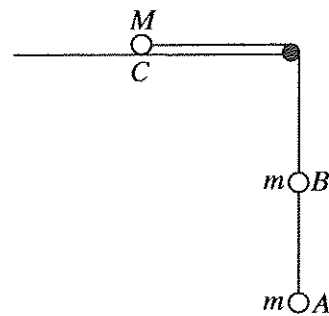

4. A car of mass M kg and constant power P kW moves downwards along a straight road of inclination α to the horizontal. There is a constant resistance of $R (> Mg \sin \alpha)$ N to its motion. At a certain instant, the acceleration of the car is a m s^{-2} . Find the velocity of the car at this instant.

Deduce that the constant speed with which the car can move downwards along the road is

$$\frac{1000P}{R - Mg \sin \alpha} \text{ m s}^{-1}.$$

- (b) A smooth narrow tube $ABCDE$ is fixed in a vertical plane as shown in the figure. The portion AB of length $2\sqrt{3}a$ is straight and tangential at B to the circular portion $BCDE$ of radius $2a$. The ends A and E lie vertically above the centre O . A particle P of mass m is placed inside the tube at A and gently released from rest. Show that the speed v of the particle P when \overrightarrow{OP} makes an angle θ ($\frac{\pi}{3} < \theta < 2\pi$) with \overrightarrow{OA} is given by $v^2 = 4ga(2 - \cos \theta)$ and find the reaction on the particle P from the tube at this instant.

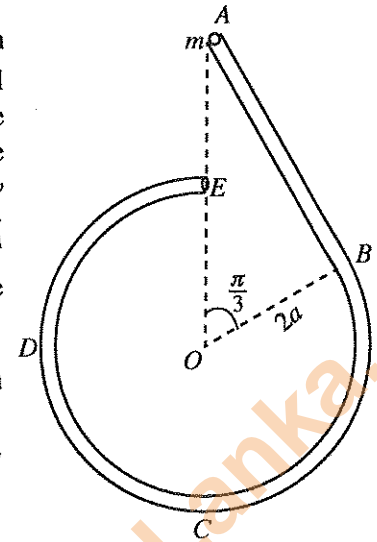

Also, find the reaction on the particle P from the tube in its motion from A to B .

Show that the reaction on the particle P from the tube changes abruptly when the particle P passes through B .

13. The points O , A and B lie in that order, with O lowermost, on a line of greatest slope of a smooth fixed plane inclined at an angle $\frac{\pi}{6}$ to the horizontal such that $OA = a$ and $AB = 2a$. One end of a light elastic string of natural length a and modulus of elasticity mg is attached to the point O and the other end to a particle P of mass m . The string is pulled along the line OAB until the particle P reaches the point B . Then the particle P is released from rest.

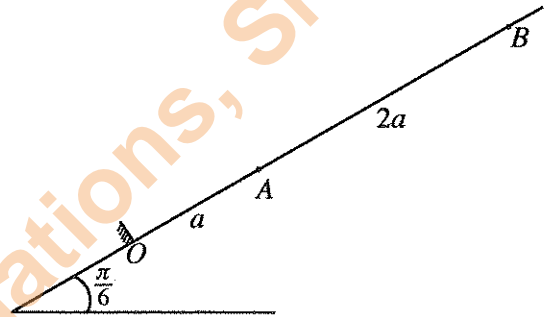

Show that the equation of motion of P from B to A is given by $\ddot{x} + \frac{g}{a}\left(x + \frac{a}{2}\right) = 0$ for $0 \leq x \leq 2a$, where $AP = x$.

Let $y = x + \frac{a}{2}$ and rewrite the above equation of motion in the form $\ddot{y} + \omega^2 y = 0$ for $\frac{a}{2} \leq y \leq \frac{5a}{2}$,

where $\omega = \sqrt{\frac{g}{a}}$.

Find the centre of the above simple harmonic motion and using the formula $\dot{y}^2 = \omega^2(c^2 - y^2)$, find the amplitude c and the velocity of P when it reaches A .

Show that the velocity of P when it reaches O is $\sqrt{7ga}$.

Show also that the time taken by P to move from B to O is $\sqrt{\frac{a}{g}} \left\{ \cos^{-1}\left(\frac{1}{5}\right) + 2k \right\}$, where $k = \sqrt{7} - \sqrt{6}$.

When the particle P reaches O , it strikes a smooth barrier fixed at O perpendicular to the plane. The coefficient of restitution between P and the barrier is e . Show that if $0 < e \leq \frac{1}{\sqrt{7}}$, then the subsequent motion of P will **not** be simple harmonic.

14. (a) Let $OACB$ be a parallelogram and let D be the point on AC such that $AD:DC = 2:1$. The position vectors of points A and B with respect to O are $\lambda\mathbf{a}$ and \mathbf{b} , respectively, where $\lambda > 0$. Express the vectors \overrightarrow{OC} and \overrightarrow{BD} in terms of \mathbf{a} , \mathbf{b} and λ .

Now, let \overrightarrow{OC} be perpendicular to \overrightarrow{BD} . Show that $3|\mathbf{a}|^2 \lambda^2 + 2(\mathbf{a} \cdot \mathbf{b})\lambda - |\mathbf{b}|^2 = 0$ and

find the value of λ , if $|\mathbf{a}| = |\mathbf{b}|$ and $\widehat{AOB} = \frac{\pi}{3}$.

- (b) A system consists of three forces in the plane of a regular hexagon $ABCDEF$ of centre O and side of length $2a$. Forces and their points of action, in the usual notation, are shown in the table below, with the origin at O , the Ox -axis along \vec{OB} and the Oy -axis along \vec{OH} , where H is the mid-point of CD . (P is measured in newtons and a is measured in metres.)

Point of Action	Position Vector	Force
A	$a\mathbf{i} - \sqrt{3}a\mathbf{j}$	$3P\mathbf{i} + \sqrt{3}P\mathbf{j}$
C	$a\mathbf{i} + \sqrt{3}a\mathbf{j}$	$-3P\mathbf{i} + \sqrt{3}P\mathbf{j}$
E	$-2a\mathbf{i}$	$-2\sqrt{3}P\mathbf{j}$

Show that the system is equivalent to a couple and find the moment of the couple.

Now, an additional force of magnitude $6P$ N acting along \vec{FE} is introduced to this system. Find the magnitude, direction and the line of action of the single force to which the new system reduces.

15. (a) Two uniform rods AB and BC , each of length $2a$ are jointed smoothly at B . The rod AB is of weight W and the rod BC is of weight $2W$. The end A is hinged smoothly to a fixed point. This system is kept in equilibrium in a vertical plane with rods AB and BC making angles α and β , respectively, with the downward vertical by a force $\frac{W}{2}$ applied at C in the direction perpendicular to BC shown in the figure. Show that $\beta = \frac{\pi}{6}$ and find the horizontal and the vertical components of the reaction at the joint B on the rod BC exerted from the rod AB .

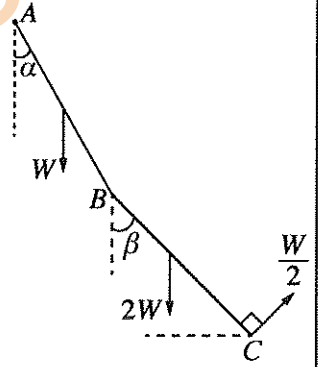

Also, show that $\tan \alpha = \frac{\sqrt{3}}{9}$.

- (b) Framework shown in the figure consists of five light rods AB , BC , BD , DC and AC smoothly jointed at their ends. Here, it is given that $AB = CB = a$, $CD = 2a$ and $\hat{BAC} = \frac{\pi}{6}$. Framework is smoothly hinged at A to a fixed point. A load W is suspended at the joint D , and the framework is kept in equilibrium in a vertical plane with AC vertical and CD horizontal by a force P parallel to the rod AB , applied at the joint C in the direction shown in the figure. Draw a stress diagram, using Bow's notation, for the joints D , B , and C .

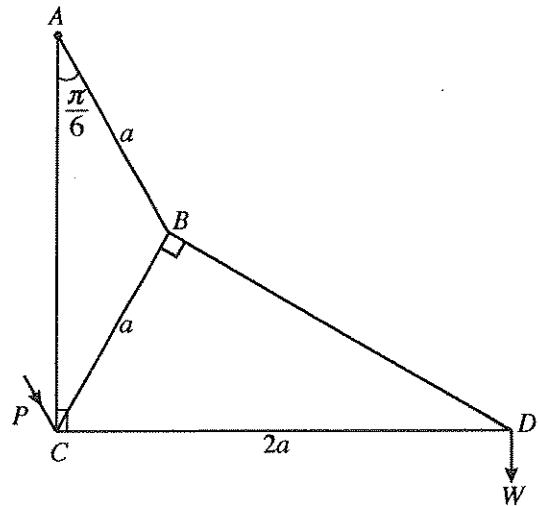

Hence, find

- the stresses in the five rods, stating whether they are tensions or thrusts, and
- the value of P .

16. Show that the centre of mass of

- (i) a thin uniform semi-circular wire of radius a is at a distance $\frac{2a}{\pi}$ from its centre, and
 (ii) a thin uniform hemispherical shell of radius a is at a distance $\frac{a}{2}$ from its centre.

A spoon is made by rigidly fixing, to a thin uniform hemispherical shell of centre O and radius $2a$, a thin handle $ABCD$ made of uniform wire consisting of a straight piece AB of length $2\pi a$ and a semi-circular piece BCD of radius a , such that the diameter BD is perpendicular to AB , as shown in the figure. The point A lies on the rim of the hemisphere, OA is perpendicular to AB , and OD is parallel to AB . Also, BCD lies in the plane of $OABD$. The mass per unit area of the hemisphere is σ and the mass per unit length of the handle is $\frac{a\sigma}{2}$.

Show that the centre of mass of the spoon lies at a distance $\frac{2}{19\pi}(8\pi - 2\pi^2 - 1)a$ below OA , and a distance $\frac{5}{19}a$ from the line passing through O and D .

The spoon is placed on a rough horizontal table with the hemispherical surface touching it. The coefficient of friction between the hemispherical surface and the table is $\frac{1}{7}$. Show that the spoon can be kept in equilibrium with OD vertical by a horizontal force applied at A in the direction of \vec{AO} .

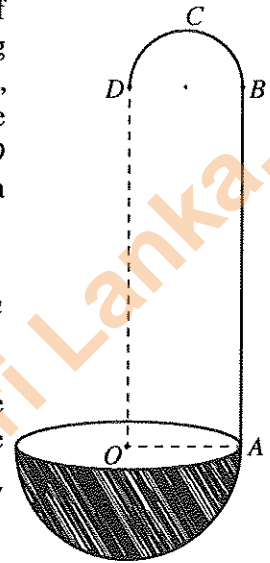

- 17.(a) Initially a box contains 3 balls identical in all aspects except for their colour, each of which is either white or black. Now, one white ball identical to balls in the box in all aspects except for its colour, is added into the box and then one ball is drawn at random from the box. Assuming that the four possible initial compositions of the balls in the box are equally likely, find the probability that
- (i) the ball drawn is white, and
 (ii) initially there were exactly 2 black balls in the box, given that the ball drawn is white.
- (b) Let the mean and the standard deviation of the set of values $\{x_i : i = 1, 2, \dots, n\}$ be μ and σ respectively. Find the mean and the standard deviation of the set of values $\{\alpha x_i : i = 1, 2, \dots, n\}$, where α is a constant.

Monthly salaries of 50 employees at a certain company are summarised in the following table:

Monthly Salary (in thousand rupees)	Number of Employees
5 – 15	9
15 – 25	11
25 – 35	14
35 – 45	10
45 – 55	6

Estimate the mean and the standard deviation of the monthly salaries of the 50 employees.

At the beginning of a year, the monthly salary of each employee is increased by $p\%$. It is given that the mean of the new monthly salaries of the above 50 employees is 29 172 rupees. Estimate the value of p and the standard deviation of the new monthly salaries of the 50 employees.