

## නව/පැරණි නිර්දේශය – புதிய/பழைய பாடத்திட்டம் – New/Old Syllabus

NEW/OLD

ශ්‍රී ලංකා විභාග දෙපාර්තමේන්තුව ශ්‍රී ලංකා විභාග දෙපාර්තමේන්තුව ශ්‍රී ලංකා විභාග දෙපාර්තමේන්තුව ශ්‍රී ලංකා විභාග දෙපාර්තමේන්තුව ශ්‍රී ලංකා විභාග දෙපාර්තමේන්තුව  
 இலங்கைப் பரீட்சைத் திணைக்களம் இலங்கைப் பரීட்சைத் திணைக்களம் இலங்கைப் பரීட்சைத் திணைக்களம் இலங்கைப் பரීட்சைத் திணைக்களம் இலங்கைப் பரීட்சைத் திணைக்களம்  
 Sri Lanka Department of Examinations, Sri Lanka Sri Lanka Department of Examinations, Sri Lanka Sri Lanka Department of Examinations, Sri Lanka Sri Lanka Department of Examinations, Sri Lanka  
 இலங்கைப் பரීட்சைத் திணைக்களம் இலங்கைப் பரීட்சைத் திணைக்களம் இலங்கைப் பரීட்சைத் திணைக்களம் இலங்கைப் பரīட்சைத் திணைக்களம் இலங்கைப் பரīட்சைத் திணைக்களம்  
 Department of Examinations, Sri Lanka Department of Examinations, Sri Lanka Department of Examinations, Sri Lanka Department of Examinations, Sri Lanka

අධ්‍යයන පොදු සහතික පත්‍ර (උසස් පෙළ) විභාගය, 2019 අගෝස්තු  
 கல்விப் பொதுத் தராதரப் பத்திர (உயர் தர)ப் பரீட்சை, 2019 ஓகஸ்ட்  
 General Certificate of Education (Adv. Level) Examination, August 2019

15.08.2019 / 1300 – 1500

විදුලිය, ඉලෙක්ට්‍රොනික හා තොරතුරු තාක්ෂණවේදය I  
 மின், இலத்திரன், தகவல் தொழினுட்பவியல் I  
 Electrical, Electronic and Information Technology I

16 E I

පැය දෙකයි  
 இரண்டு மணித்தியாலம்  
 Two hours

## Instructions:

- \* Answer **all** the questions.
- \* Write your **Index Number** in the space provided in the answer sheet.
- \* Use of calculators is not allowed.
- \* Instructions are given on the back of the answer sheet. Follow them carefully.
- \* In each of the questions 1 to 50, pick one of the alternatives from (1), (2), (3), (4), (5) which is **correct** or **most appropriate** and mark your response on the answer sheet with a cross (x) in accordance with the instructions given in the back of the answer sheet.

1. Of which of the following is the 'light year' a unit?

- (1) light intensity (2) mass (3) time (4) distance (5) frequency

● Answer questions 2 to 3 using the following graph.

The graph shows the motion of a landing aircraft after it touches down the runway. After 3 seconds of sudden deceleration, it moves in a constant velocity of 10 m/s until 6<sup>th</sup> second.

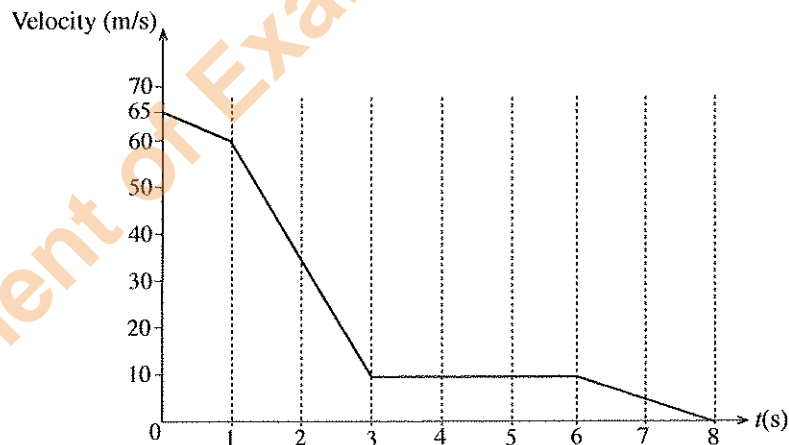

2. What is the displacement of the aircraft during its first 3 seconds?

- (1) 132.5 m (2) 140 m (3) 185 m (4) 212.5 m (5) 215 m

3. What is the average deceleration of the aircraft, if it comes to a stop in 8 seconds?

- (1)  $[(65 - 60) / 1 + (60 - 10) / 2 + (10 - 0) / 5] \div 8 \text{ ms}^{-2}$   
 (2)  $[(65 - 60) / 1 + (60 - 10) / 2 + (10 - 0) / 5] \text{ ms}^{-2}$   
 (3)  $(65 - 60) / 3 + (10 - 0) / 5 \text{ ms}^{-2}$   
 (4)  $(65 - 0) / 4 \text{ ms}^{-2}$   
 (5)  $(65 - 0) / 8 \text{ ms}^{-2}$

4. Select the resistor arrangement which has the lowest resistance between points A and B.

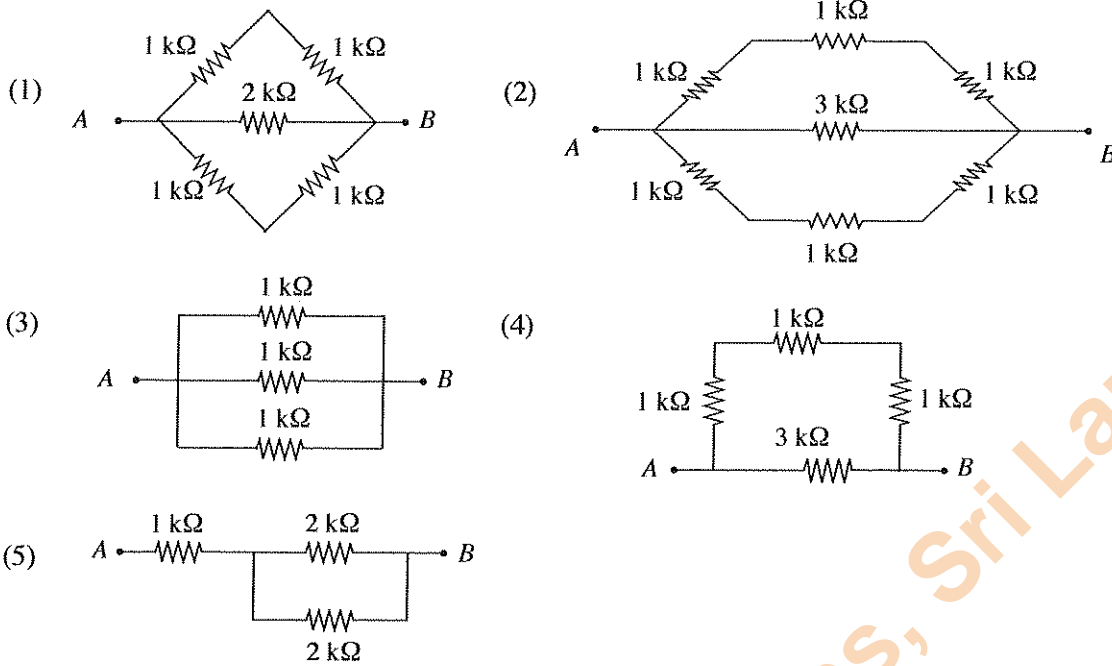

5. Consider following battery arrangements prepared by a student. What are the minimum voltage ( $V_{min}$ ) and maximum voltage ( $V_{max}$ ) obtained between A and B points?

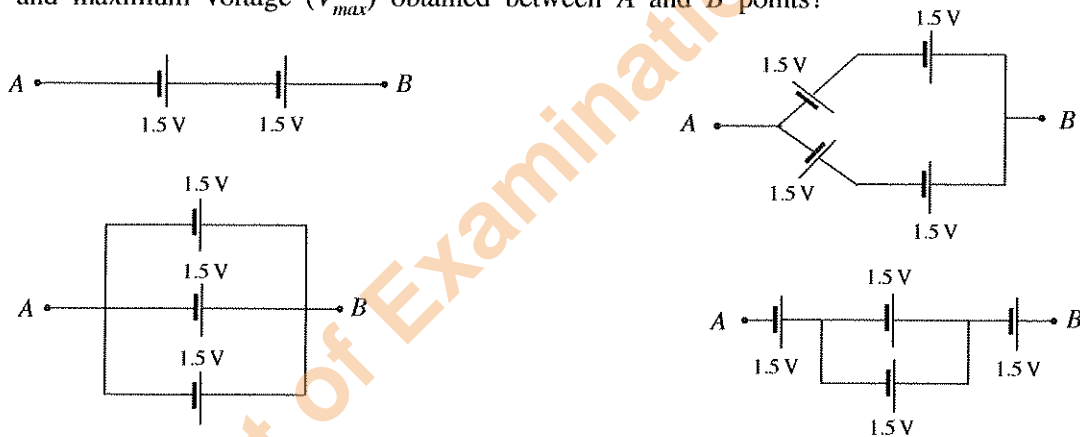

- (1)  $V_{min} = 0.5\text{ V}$ ,  $V_{max} = 4.5\text{ V}$       (2)  $V_{min} = 1.5\text{ V}$ ,  $V_{max} = 4.5\text{ V}$   
 (3)  $V_{min} = 1.5\text{ V}$ ,  $V_{max} = 3.0\text{ V}$       (4)  $V_{min} = 3.0\text{ V}$ ,  $V_{max} = 4.5\text{ V}$   
 (5)  $V_{min} = 5.0\text{ V}$ ,  $V_{max} = 15.0\text{ V}$

6. Three ideal voltmeters and one ideal ammeter are connected in a circuit as shown in the figure. What is the correct answer with correct reading of  $M_1$ ,  $M_2$ ,  $M_3$  and  $M_4$  in same order?

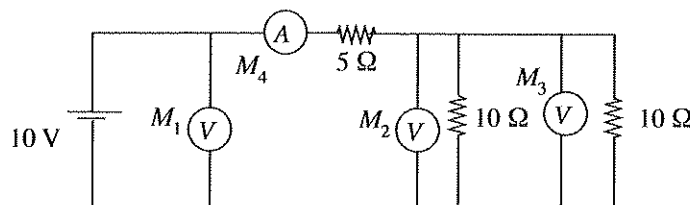

- (1) 5V, 2.5V, 2.5V, 1A      (2) 10V, 5V, 5V, 2A      (3) 10V, 10V, 5V, 1A  
 (4) 10V, 5V, 5V, 1A      (5) 5V, 5V, 5V, 2A
7. Select the answer with correct parameters of standard domestic electricity supply of Sri Lanka.
- (1) 230V AC, 60Hz      (2) 230V DC, 50Hz      (3) 230V AC, 50Hz  
 (4) 260V AC, 60Hz      (5) 260V AC, 90Hz

Department of Examinations, Sri Lanka.

8. Which of the following is **not** a software used in computer?

- (1) MS Office
- (2) C++
- (3) JAVA
- (4) MS Word
- (5) Hard disk

9. Figure A and B show two V-pulleys driven by a V-belt and a round rope respectively. Belt and rope both do not touch the flat surface of the V-groove and the shape of the rope remains unchanged. Select the correct statement about its functioning from the following.

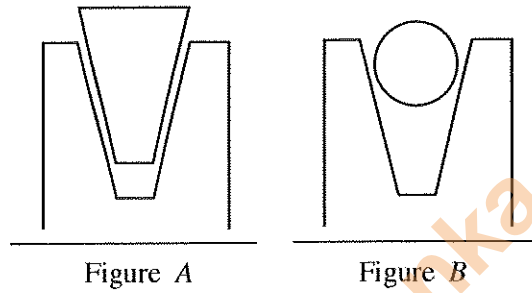

- (1) V-belt and rope should have same tension before slip.
- (2) V-belt slips first.
- (3) Rope slips first.
- (4) Slip cannot be analytically explained.
- (5) Slip depends on the diameter of the rope.

10. A common function of solar PV cells and Solar hot water heaters is

- (1) generation of electricity.
- (2) generation of heat.
- (3) generation of water.
- (4) generation of both heat and electricity.
- (5) generation of noise.

11. Which of the following energy forms can be converted into work in a most efficiently way?

- (1) electricity
- (2) heat
- (3) pneumatic
- (4) sea wave
- (5) wind

12. Consider the following statements on renewable energy sources.

- A - Solar energy is renewable.
- B - Biomass is non-renewable.
- C - Coal is renewable.
- D - Hydro power is non-renewable.

Which of the above statements are **incorrect**?

- (1) A, B and C only.
- (2) A, B and D only.
- (3) A, C and D only.
- (4) B, C and D only.
- (5) All A, B, C and D.

13. What measuring instrument can be used to measure accurately the depth ( $h$ ) and the internal diameter ( $d$ ) of a test tube?

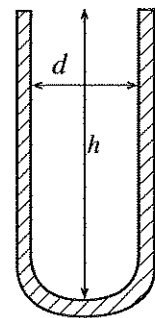

- (1) Micrometer screw gauge
- (2) Meter ruler
- (3) Vernier calliper
- (4) Measuring tape
- (5) Protractor

14. Which option gives the plan view of the machine component shown in figure?

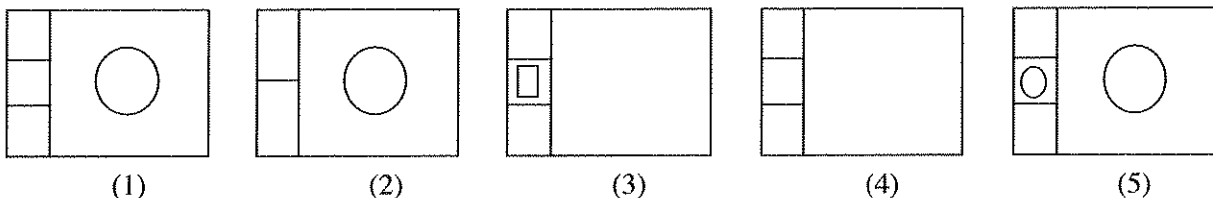
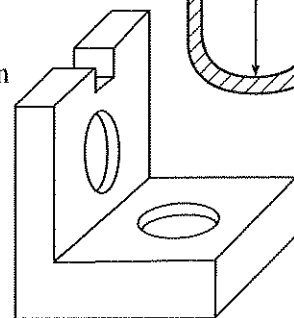

- A bar is at a stable position as in the figure below. Use the figure to answer questions 15 and 16.

15. Select the correct answer.

- (1)  $\omega = T, Q + T \cos 30^\circ = W$
- (2)  $\omega = T \cos 30^\circ, Q + T = W$
- (3)  $\omega = T, Q + T = W$
- (4)  $\omega = T \sin 30^\circ, Q - T \cos 30^\circ = W$
- (5)  $\omega = 2T, Q + T \cos 30^\circ = W$

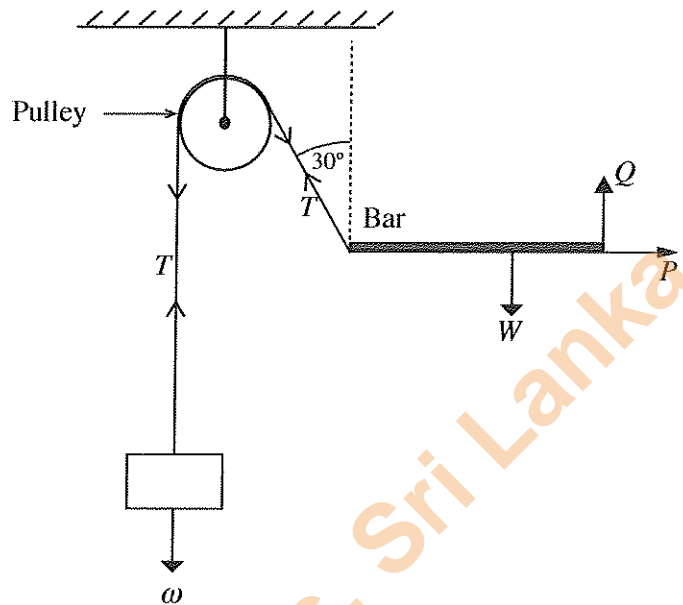

16. What is the value of  $P$ ?

- (1)  $\omega$
- (2)  $\omega \sin 30^\circ$
- (3)  $\omega \cos 30^\circ$
- (4)  $W + \omega \sin 30^\circ$
- (5)  $W + \omega$

17. Consider the following statements.

- A - Frictional coefficient between two metal is higher than that of metal on ice.
- B - Frictional coefficient is expected to reduce when a surface begins to move over the other.
- C - Sand is sometimes used to increase traction between two surfaces.
- D - Surface roughness has negligible influence when determining the theoretical frictional force.

Which of the above statements are true about sliding between two surfaces?

- (1) A, B and C only.
- (2) A, B and D only.
- (3) A, C and D only.
- (4) B, C and D only.
- (5) All A, B, C and D.

18. A 10 W LED Lamp is installed in a house. It is consuming 10% more power due to an internal fault in the lamp. It is switched ON for 5 hours daily. What is the monthly (30 days) energy consumption?

- (1) 0.165 kWh
- (2) 0.55 kWh
- (3) 1.65 kWh
- (4) 5.5 kWh
- (5) 16.5 kWh

19. When extinguishing a fire caused due to a volatile flammable liquid, best material to be used is

- (1) dry chemical spray.
- (2) carbon dioxide jet.
- (3) compressed air jet.
- (4) water jet.
- (5) foam extinguisher.

20. A human being inhales about 78% Nitrogen, 21% Oxygen and 1% others. Exhales 4% Water vapour, 75% Nitrogen, 16% Oxygen, and 4% Carbon dioxide. Which of the following statements are true?

- A - The body uses oxygen to breakdown foods to create energy.
- B - Carbon dioxide is produced by human cells.
- C - Water vapour is produced from moisture in the respiratory system.
- D - Exhaled air is warmer than the inhaled air.

- (1) A, B and C only.
- (2) A, B and D only.
- (3) A, C and D only.
- (4) B, C and D only.
- (5) All A, B, C and D.

21. A vehicle travels along a straight road from point A to B and its velocity is as shown in the figure below.

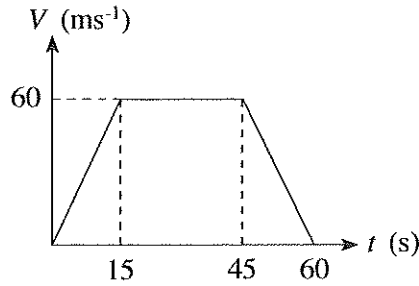

Which diagram indicates the acceleration ( $a$ ) of the vehicle?

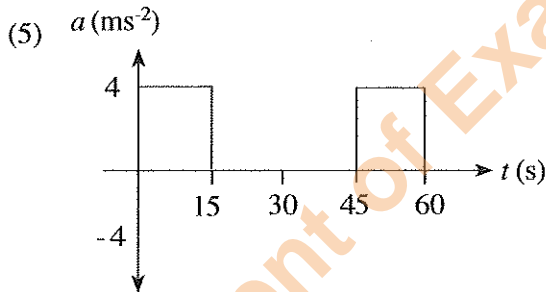
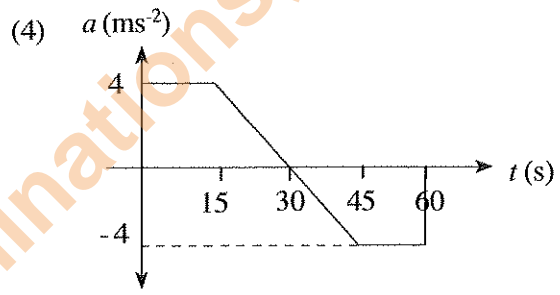
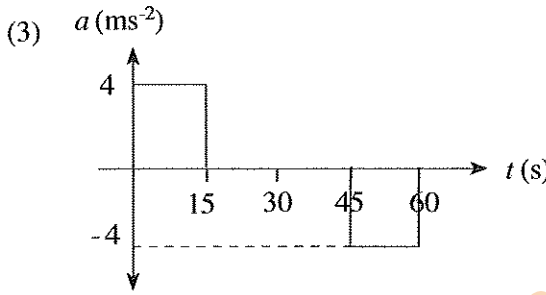
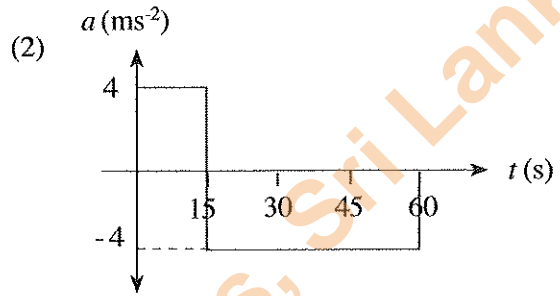
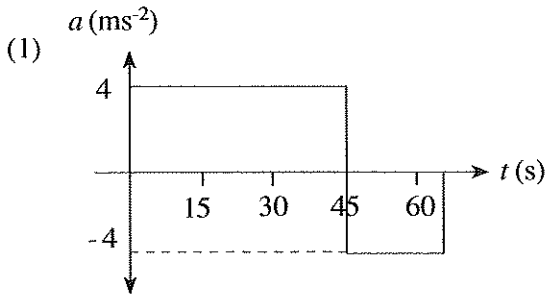

22. The roof truss shown in the figure is used to support roof loadings,  $W_1, W_2, W_3, W_4$  and  $W_5$ . In order to reduce central deflection due to roof loading, following suggestions have been proposed.

- A - Add more diagonal members
- B - Remove few diagonal members
- C - Increase section areas of lower and bottom chord members
- D - Connections are welded again.

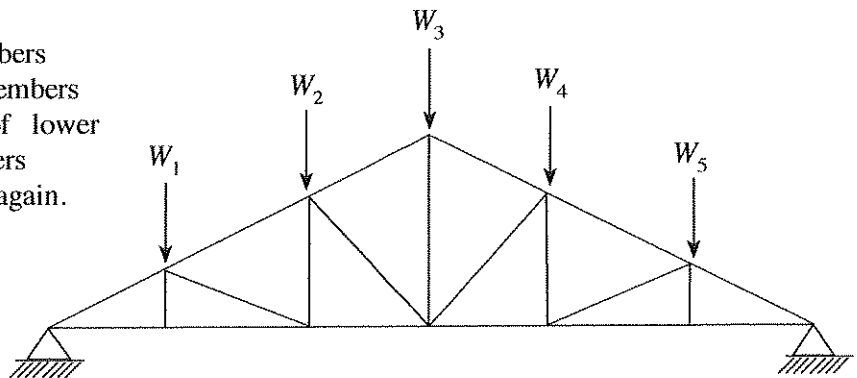

Which of the above suggestions are correct?

- (1) A and B only.
- (2) A and C only.
- (3) A and D only.
- (4) B and C only.
- (5) B and D only.

23. A hollow cement block is subjected to 10 kN load as shown in the figure. Axial Compressive stress applied on the block is
- (1) 33 kPa.      (2) 50 kPa.      (3) 0.33 MPa.  
 (4) 0.5 MPa.    (5) 5 MPa.

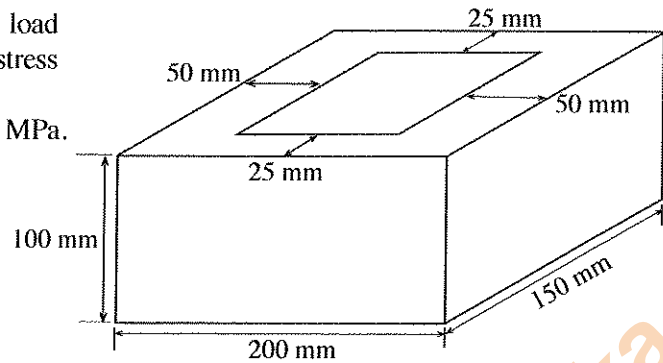

24. 600 kg weight is lifted through the portable jack as shown in the figure. The Force applied at the arm AB is
- (1) 300 kg.      (2) 450 kg.      (3) 600 kg.  
 (4) 1000 kg.    (5) 8000 kg.

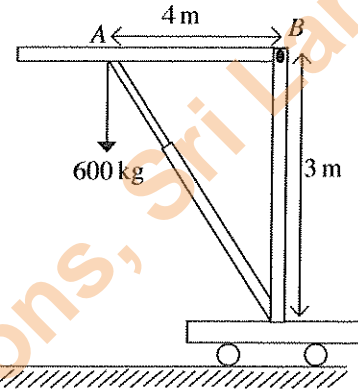

25. Which of the following skills can be observed in an efficient street-side cobbler, who mends footwear?
- A - Passion to serve customers  
 B - Strong personal skills.  
 C - Creativity.  
 D - Competitiveness.
- (1) A, B and C only.      (2) A, B and D only.      (3) A, C and D only.  
 (4) B, C and D only.    (5) All A, B, C and D.

26. Following diagram shows the Rotor of a motor. What is the type of motor?
- (1) Direct current shunt motor  
 (2) Direct current series motor  
 (3) Squirrel cage type induction motor  
 (4) Direct current compound motor  
 (5) Universal motor

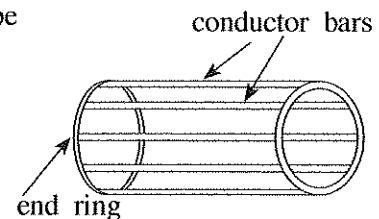

27. Consider the following statements.
- A - Direct current series motors are used in traction applications of electric trains.  
 B - Speed of shunt wound direct current motor can be controlled at a constant value.  
 C - Compound direct current motors have characteristics of both series direct current motors and shunt direct current motors upto some extent.
- Select the correct answer with statement/statements regarding direct current motors.
- (1) A only                      (2) B only                      (3) C only  
 (4) A and B only              (5) All A, B, and C

28. What element can be used to obtain a  $p$ -type semiconductor through doping silicon?
- (1) P                      (2) B                      (3) Sb                      (4) Bi                      (5) K

29. What is the current going through  $R_L$  of the following circuit?

- (1)  $2 \mu\text{A}$       (2)  $0.5 \text{ mA}$       (3)  $1.5 \text{ mA}$   
 (4)  $2 \text{ mA}$       (5)  $2 \text{ A}$

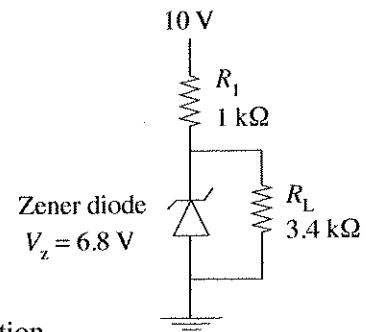







30. Consider the following statements.

- A - Current gain is greater than one in the common-base configuration.  
 B - Voltage gain is greater than one in the common-emitter configuration.  
 C - There exists a  $180^\circ$  phase difference between the input and output in the common-emitter configuration.

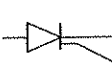
Select the correct statement/statements from the above statements.

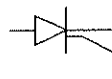
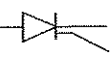
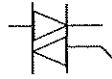
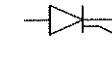
- (1) B only      (2) A and B only      (3) A and C only  
 (4) B and C only      (5) All A, B, and C

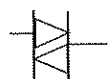
31. Which option shows the symbols of an SCR and a DIAC, respectively?

- (1)  and       (2)  and   
 (3)  and       (4)  and   
 (5)  and 

32. Consider the following statements.

- A- Open-loop voltage gain is infinite.  
 B- The input resistance is zero.  
 C- The output resistance is infinite.  
 D- The operational bandwidth is infinite.

Which of the above statements are true regarding an ideal operational amplifier?

- (1) A and D only      (2) B and C only      (3) C and D only  
 (4) A, B and C only      (5) All A, B, C and D

33. What is the voltage gain of the following amplifier?

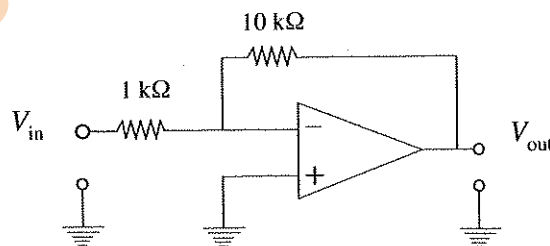

- (1) -11      (2) -10      (3) -0.1      (4) 0.1      (5) 20

34. What is the frequency range used for frequency modulation (FM) radio transmission in Sri Lanka?

- (1)  $88 - 108 \text{ kHz}$       (2)  $80 - 100 \text{ MHz}$       (3)  $88 - 108 \text{ MHz}$   
 (4)  $98 - 108 \text{ MHz}$       (5)  $1 - 3 \text{ GHz}$

35. The input signal  $x(t)$  and the carrier signal  $c(t)$  for amplitude modulation (AM) are shown below.

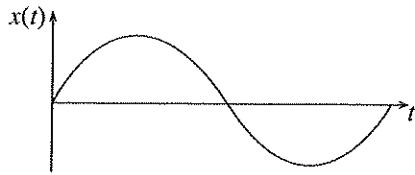

Input signal

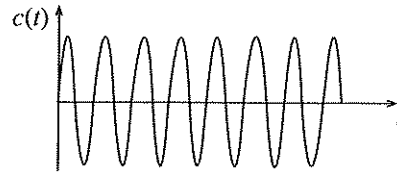

Carrier signal

What is the amplitude modulated waveform  $y(t)$ ?

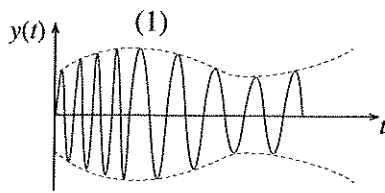
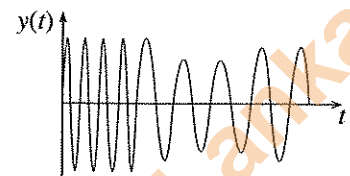
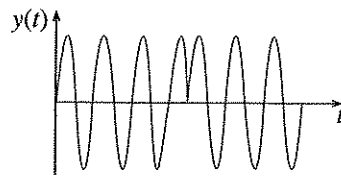
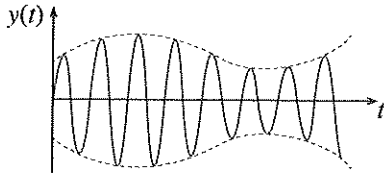

(1)

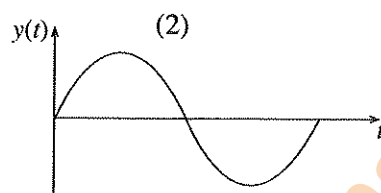

(2)

(3)

36. What is the output of the following logic circuit?

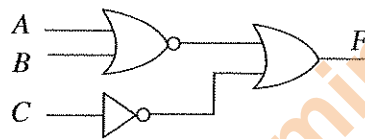

(1)  $A + B + \bar{C}$

(2)  $\bar{A} + \bar{B} + \bar{C}$

(3)  $\overline{A + B + C}$

(4)  $\overline{A + B} + C$

(5)  $\overline{A + B} + \bar{C}$

37. What is the equivalent logic gate for the following logic circuit?

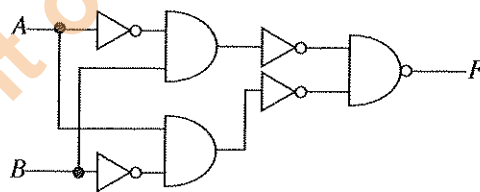

(1) NAND

(2) NOR

(3) AND

(4) XNOR

(5) XOR

38. Three capacitors 1, 2 and 3 are connected in parallel. What is the total capacitance of the network?

	Cross section	Distance between plates	Permittivity of medium
Capacitor 1	$A$	$3d$	$\epsilon$
Capacitor 2	$2A$	$2d$	$\epsilon$
Capacitor 3	$3A$	$d$	$\epsilon$

(1)  $\frac{A\epsilon}{d}$

(2)  $\frac{2A\epsilon}{d}$

(3)  $\frac{13A\epsilon}{3d}$

(4)  $\frac{A\epsilon}{2d}$

(5)  $\frac{A\epsilon}{3d}$

39. Three conductors A, B and C are connected as shown in the figure. What is the total resistance? (Assume that the resistance of connecting conductor is zero.)

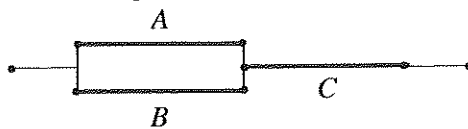

	Cross section	Length	Resistivity
Conductor A	$2a$	$2l$	$\rho$
Conductor B	$2a$	$2l$	$\rho$
Conductor C	$2a$	$l$	$\rho$

- (1)  $\frac{\rho l}{a}$       (2)  $\frac{2\rho l}{a}$       (3)  $\frac{5\rho l}{2a}$       (4)  $\frac{4\rho l}{a}$       (5)  $\frac{6\rho l}{a}$

40. Select the **incorrect** statement regarding the DC circuit given in the figure.

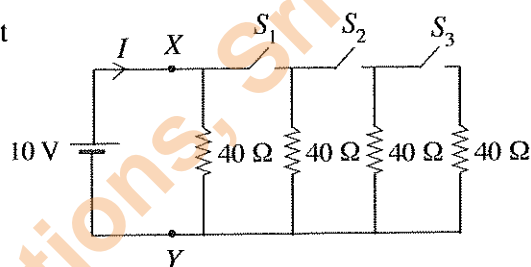

- (1) Current supplied by the DC source ( $I$ ) is lowest when all switches ( $S_1$ ,  $S_2$  and  $S_3$ ) are closed.  
 (2) Total resistance between  $X$  and  $Y$  points is  $40\ \Omega$  when all switches are open.  
 (3) Total resistance between  $X$  and  $Y$  points is  $10\ \Omega$  when all switches are closed.  
 (4)  $I=0.5\ \text{A}$  when  $S_1$  is closed and  $S_2$ ,  $S_3$  are open.  
 (5) All resistors will consume same power when all switches are closed.
41. Consider statements related to following two circuits.  $R$  pure resistor and  $B$  incandescent lamp are identical in both circuits.

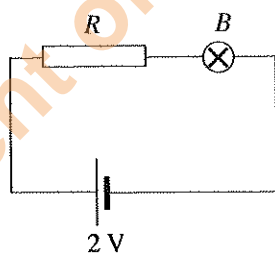

Circuit 1

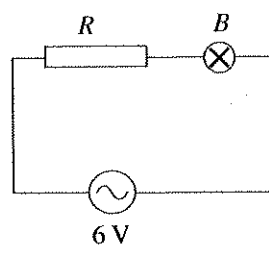

Circuit 2

- A- Bulb  $B$  will have same brightness in both circuits.  
 B- Supply AC voltage and circuit current are in phase in the circuit 2.  
 C- Supply AC voltage and circuit current has phase shift of  $90^\circ$  in the circuit 2.

Among the above select the answer that gives correct statement/statements.

- (1) A only      (2) B only      (3) C only  
 (4) A and B only      (5) All A, B and C



46. Consider the following statements regarding three phase Alternating current supply.

- A - There is a phase shift of  $120^\circ$  between phases.
- B - In a star connected source, phase voltage  $V_p = \sqrt{3} V_L$ ,  $V_L$  is line voltage.
- C - Phase waveform is as in the figure.

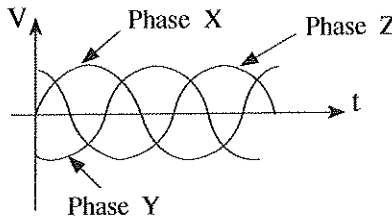

Select the answer with correct statement/statements.

- (1) A only
- (2) B only
- (3) C only
- (4) A and B only
- (5) All A, B and C

47. Consider the line diagram of a domestic circuit given in the figure and select the answer with the correct type of the circuit.

- (1) Circuit with a switch and a lamp.
- (2) Circuit with two way switch arrangement and a lamp.
- (3) Circuit with two socket outlets and a lamp.
- (4) Circuit with two socket outlets.
- (5) Circuit with a socket outlet and a lamp.

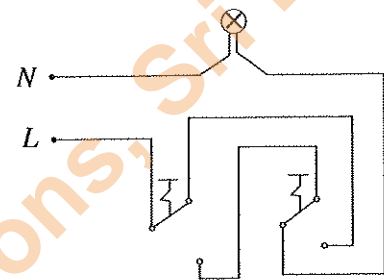

• Answer questions 48, 49 and 50 based on the following production process.

Consider the following conveyor used in the production process is operated by motor  $M$ . Three types of metal boxes are produced. Type 1 and Type 2 boxes will be stored in  $C_1$  by actuating  $A$  actuator. Type 3 will be stored in  $C_2$ .

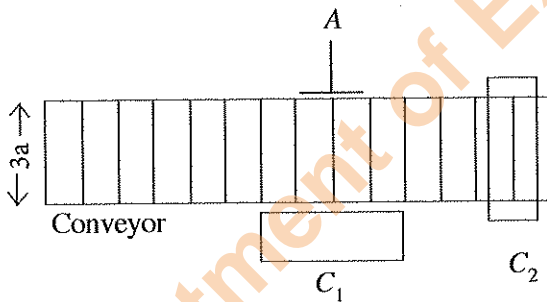

Plan view of production line

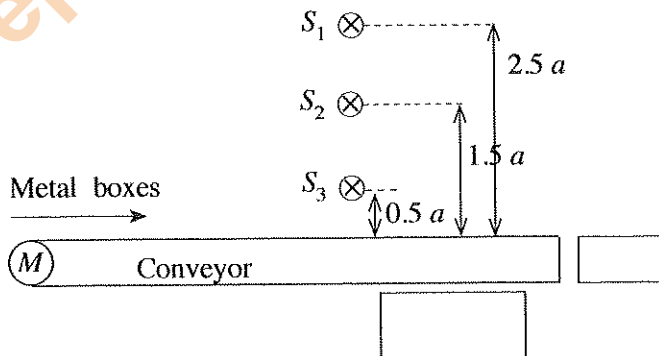
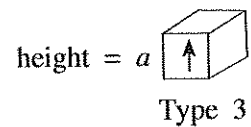
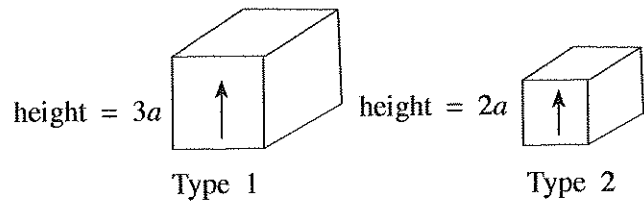

Department of Examinations, Sri Lanka.

48. Assume that the sensor's output will be logic '1' ( $S_1, S_2$  and  $S_3$ ), when the sensor is covered by a metal box. Furthermore, the sensor output will be '0', when there is no metal box in front. Select the correct sequence of outputs for following sequence of box production.

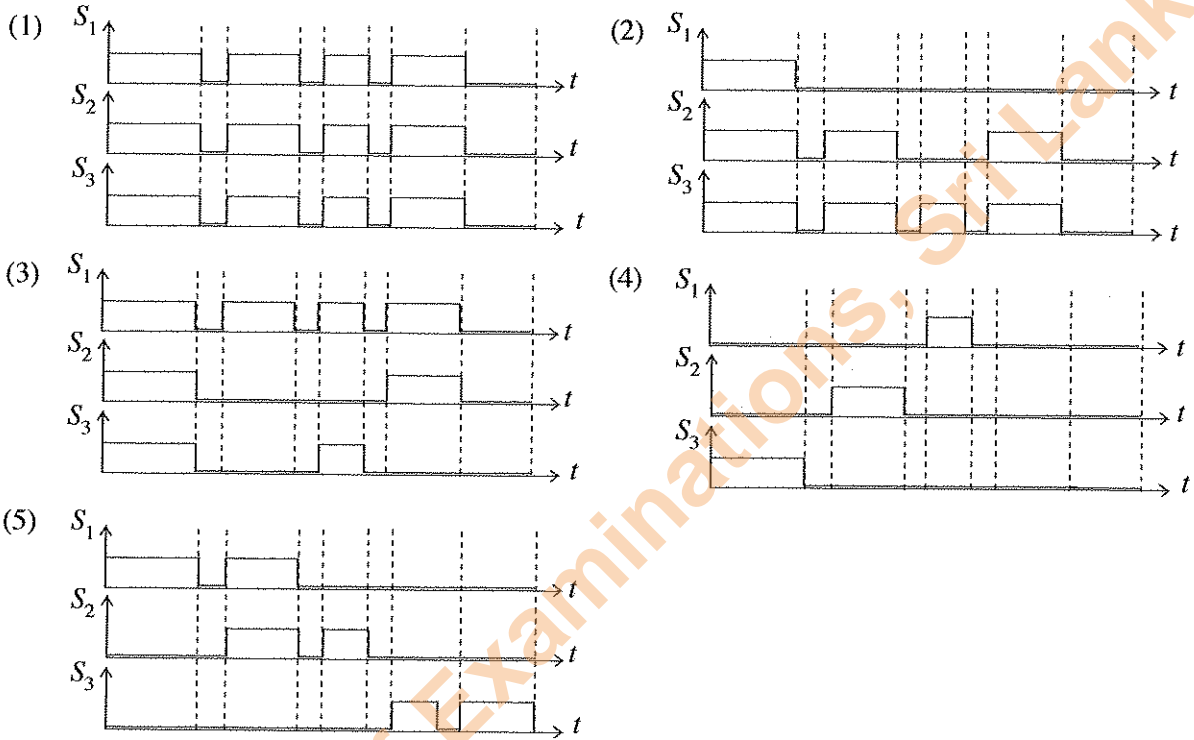
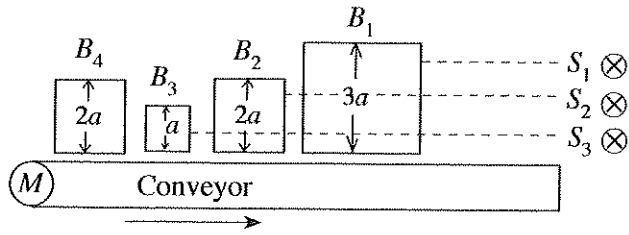

49. Select the answer with correct logic circuits for activating A.

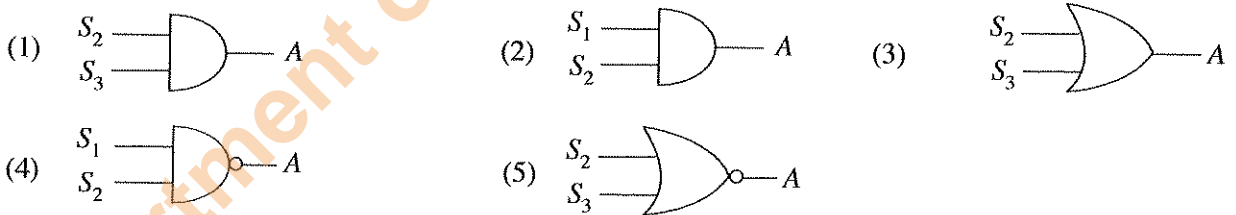

50. Consider the following outputs of  $S_1, S_2$  and  $S_3$  sensors were observed during another production sequence. Select the answer with correct number of boxes available in each output container ( $C_1$  and  $C_2$ ) after the production sequence is over.

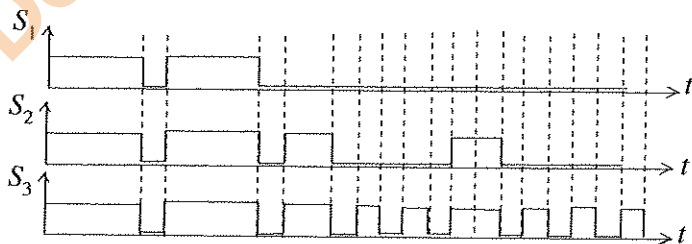

- (1)  $C_1 = 4, C_2 = 5$
- (2)  $C_1 = 5, C_2 = 4$
- (3)  $C_1 = 4, C_2 = 4$
- (4)  $C_1 = 0, C_2 = 9$
- (5)  $C_1 = 9, C_2 = 0$

**වෙ/වැරේ නිර්දේශය – புதிய/பழைய பாடத்திட்டம் – New/Old Syllabus**

**NEW/OLD**

අධ්‍යයන පොදු සහතික පත්‍ර (උසස් පෙළ) විභාගය, 2019 අගෝස්තු  
கல்விப் பொதுத் தராதரப் பத்திர (உயர் தர)ப் பரீட்சை, 2019 ஓகஸ்ட்  
General Certificate of Education (Adv. Level) Examination, August 2019

විදුලිය, ඉලෙක්ට්‍රොනික හා තොරතුරු තාක්ෂණවේදය II  
மின், இலத்திரன் தகவல் தொழினுட்பவியல் II  
**Electrical, Electronic and Information Technology II**

**16 E II**

**17.08.2019 / 1300 – 1610**

පැය තුනයි  
மூன்று மணித்தியாலம்  
**Three hours**

අමතර කියවීමේ කාලය - මිනිත්තු 10 යි  
மேலதிக வாசிப்பு நேரம் - 10 நிமிடங்கள்  
**Additional Reading Time - 10 minutes**

Use **additional reading time** to go through the question paper, select the questions and decide on the questions that you give priority in answering.

Index No. : .....

**Important :**

- \* This question paper consists of **II** pages.
- \* This question paper comprises **Parts A, B and C**. The time allotted for **all parts** is **three hours**. (Use of calculators is **not** allowed.)

**Part A - Structured Essay (08 pages)**

- \* Answer **all** the questions on this paper itself.
- \* Write your answers in the space provided for each question. Note that the space provided is sufficient for your answers and that extensive answers are not expected.

**Part B and C - Essay (03 pages)**

- \* Select minimum of **two** questions from each of the parts **B** and **C** and answer **four** questions only. Use the papers supplied for this purpose. At the end of the time allotted for this paper, tie the **three parts** together so that **Part A** is on the top of **Part B** and **C** before handing over to the supervisor.
- \* You are permitted to remove only **Parts B and C** of the question paper from the Examination Hall.

**For Examiner's Use Only**

Part	Q. No.	Marks
<b>A</b>	1	
	2	
	3	
	4	
<b>B</b>	1	
	2	
	3	
	4	
<b>C</b>	5	
	6	
	Total	

Total	
In Numbers	
In Words	

Code Numbers	
Marking Examiner 1	
Marking Examiner 2	
Checked by	
Supervised by	

**PART A – Structured Essay**  
 Answer *all four* questions on this paper itself.  
 (Each question carries **10** marks)

Do not  
 write  
 in this  
 column

1. An isometric view of a machine component is shown in the figure. Machine component is symmetric along the vertical plane passing through X-X. Assuming any missing dimensions, draw the following views to a suitable scale using first angle projection principle. Show all relevant dimensions in the sketches. Use the graph sheets given on page 3 and 4 to answer the questions. (All dimensions are in mm.)

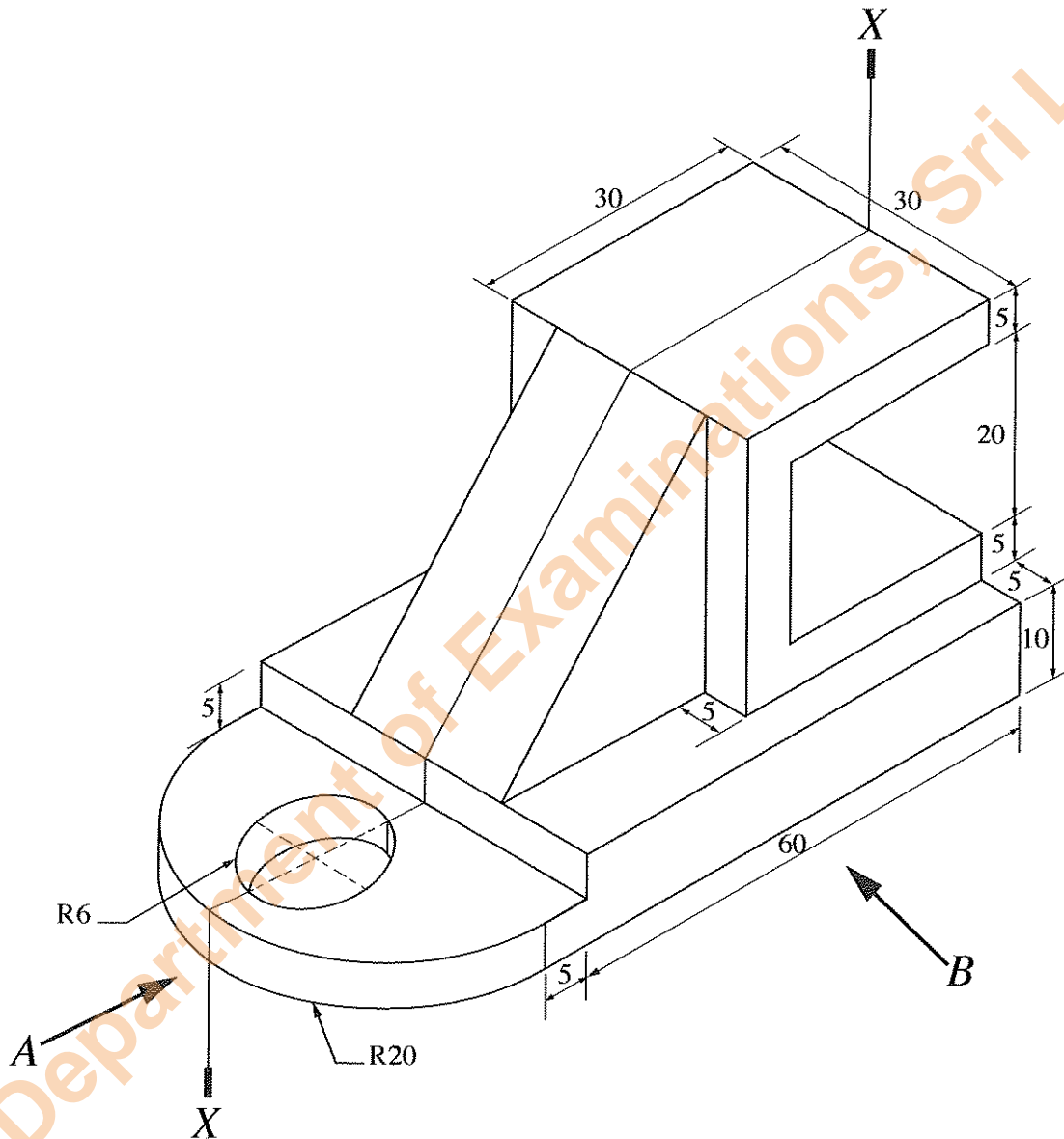

- (i) Front elevation seen through direction A.
- (ii) End elevation seen through direction B.
- (iii) Plan.

[see page three

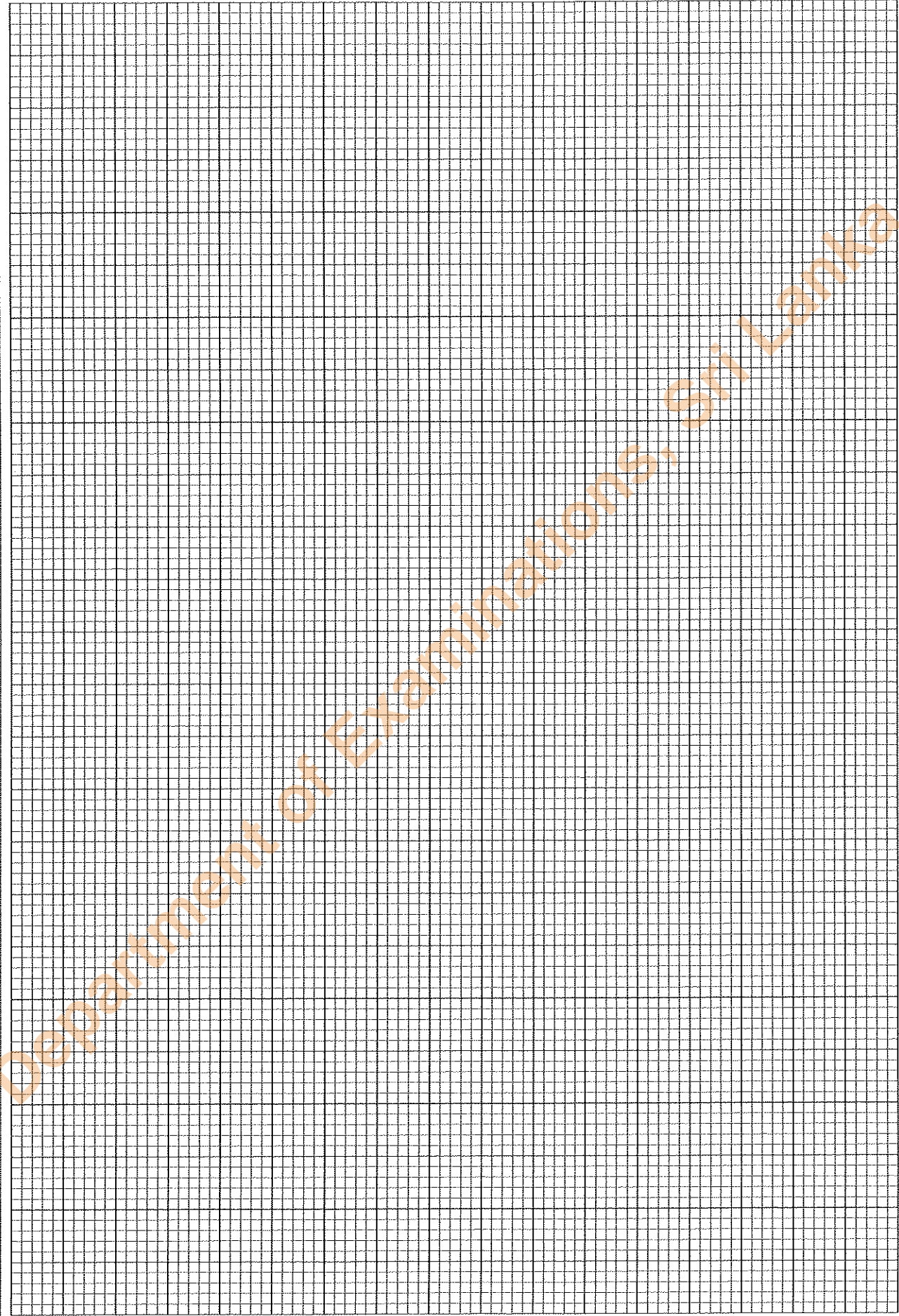

[see page four



[see page five

Department of Examinations, Sri Lanka

Department of Examinations, Sri Lanka.

Do not write in this column

2. A group of teachers from City School are planning to have an interactive classroom with following special functions.

They have installed an interactive multimedia projector. Teacher can write on the board by using a digital pen and content can be stored in the memory. Digital pen is not an ink pen. It will show in display in digital form. Content can be transferred to the computer connected at the teacher's desktop. Further, this can be used to comment on top of other content such as power point presentations, word documents, web pages etc.

Furthermore, they have planned to use this interactive classroom for getting the service of university lecturers using video conferencing facilities. Students are given facilities to interact with the lecturer.

Assume you are assigned to give the Information Technology support for the team.

(a) State **three** software required for the laptop at the teacher's desk in addition to specific software and drivers of interactive display.

- (1) .....
- (2) .....
- (3) .....

(b) State **three** types of additional hardware required for the interactive classroom in addition to computers or laptops.

- (1) .....
- (2) .....
- (3) .....

(c) Assume all student are using their laptops. State **two** options for networking student laptops and connecting them with the teacher's laptop.

- (1) .....
- (2) .....

(d) Students are requested to submit their classroom assignments online. State **one** facility suitable for this purpose.

.....  
.....

(e) In group activities, students are requested to collaboratively develop group reports. State **one** facility suitable for this purpose.

.....  
.....



Department of Examinations, Sri Lanka.

Do not write in this column

3. A circuit in which an NPN transistor is used as an amplifier is shown below. Assume that  $\beta = 100$  and the transistor is made from silicon.

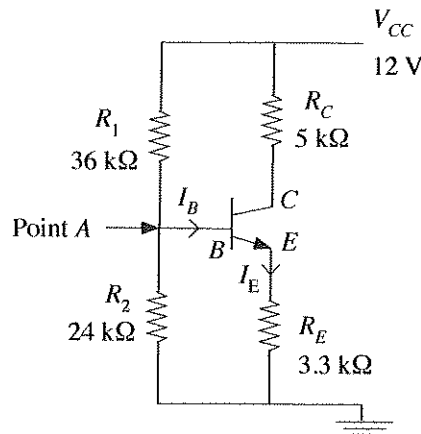

(a) State the biasing method used in the circuit.

.....

.....

(b) State the transistor configuration used in the circuit.

.....

.....

(c) Assuming that the current  $I_B$  is very small compared to the current going through  $R_1$  and  $R_2$ , determine the voltage at point A.

.....

.....

.....

.....

.....

.....

.....

.....

.....

.....

(d) Assuming that transistor is in the active region, determine the current  $I_E$ .

.....

.....

.....

.....

.....

.....

.....

.....

.....

.....

Department of Examinations, Sri Lanka.

Do not write in this column

(e) Determine the voltages  $V_{CE}$  and  $V_{BC}$ .

.....

.....

.....

.....

.....

.....

.....

.....

4. Following figure shows a circuit where a resistor is connected in series with a pure inductor.

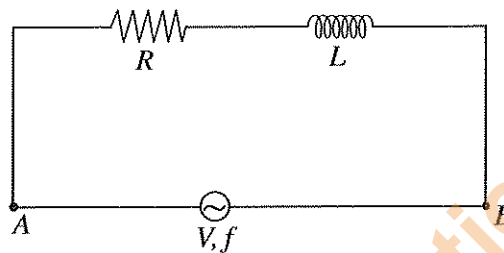

(a) Write an expression for inductive reactance  $X_L$  of the inductor  $L$ .

.....

.....

.....

(b) Write an expression for the total impedance.

.....

.....

.....

(c) Calculate the total impedance when  $R=10\ \Omega$ ,  $L=10\text{mH}$  and supply voltage is 100V AC (50 Hz).

.....

.....

.....

.....

.....

.....

.....

.....

.....

Department of Examinations, Sri Lanka.

(d) Calculate the power factor of the *RL* series load.

.....

.....

.....

.....

.....

.....

.....

.....

.....

.....

.....

.....

.....

Do not write in this column

\* \*

Department of Examinations, Sri Lanka.

Department of Examinations, Sri Lanka.



Before buying PHEV, the average energy consumption was 200 units per month. Domestic customer Tariff for electricity is as follows.

Monthly Consumption (kWh)	Unit charge (Rs.)
0 – 60	8
61 – 90	10
91 – 120	28
121 – 180	32
>180	45

Fixed charge for a customer above 180 units usage per month is Rs. 540.00.

- What is total energy generated by the 2kW PV roof top per month?
  - What is the total energy consumed by the 'PHEV' for charging per month?
  - What is the total income from selling energy to Ceylon Electricity Board?
  - What is the Net-Electricity Bill per month?
  - Assuming the Petrol cost is Rs. 150.00 and from one litre the vehicle can run 10km, what is your opinion regarding the usage of charging PHEV using main supply?
3. World elderly population increase rapidly. However, there is a problem of availability of skilled care givers and new generation is busy with their daily activities. Technological solutions are being developed to address this problem. The elderly people prefer to be in their homes rather than living in special elderly care homes.
- Discuss **three** technological innovations that can be used to improve physical and mental well-being of the elderly.
  - Select **one** technological innovation mentioned in (a) above and explain how it can be used to keep elderly in their own homes rather than in a home for elders, taking into consideration the busy life style of the present generation.
  - Discuss **two** instances where technology can assist elderly people to attend to their daily activities independently.

### Part C

4. (a) A combinational logic circuit with three inputs and one output is shown below.

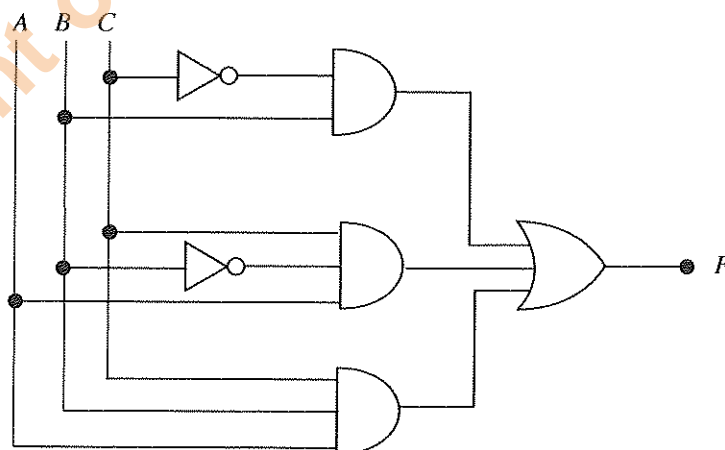

- Determine the Boolean expression for the output  $F$  of the circuit.
- Using relevant axioms and theorems, simplify the above Boolean expression in order to obtain the most simplified Boolean expression.
- Prepare the truth table corresponding to the most simplified Boolean expression obtained in part (ii) above.
- Explain whether the above circuit can be used to identify the prime numbers between 0 and 7.
- Draw the logic circuit corresponding to the most simplified Boolean expression obtained in part (ii) above.

[see page eleven

- (b) (i) Draw the circuit of an SR flip-flop using NOR gates.  
 (ii) The input signals of a positive-edge triggered JK flip-flop are shown below. If the initial state of the output Q is 0, draw the output of the JK flip-flop with the clock signal.

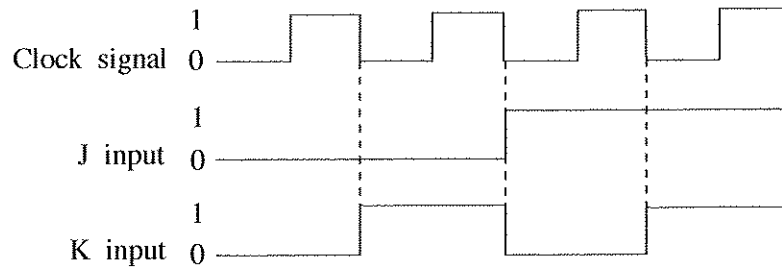

5. Assume that you have been requested to develop a new web interface for a student project. Structure of the interface is given below. Here 'ON', 'OFF' and 'Pause' link to hardware components. (Assume that they have implemented similar to a web link to other pages.)

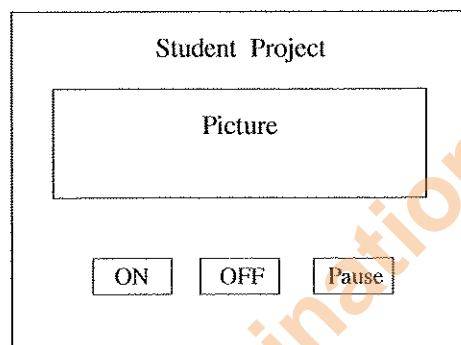

- (a) Write a program with HTML tags to develop the above web interface.  
 (b) The students are planning to develop a help page as a new page. They wanted to include a video of an experiment, detailed steps as a series of images and descriptions. The experiment setup is as shown below.

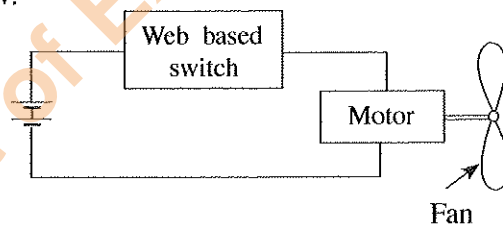

- (i) Give the details of your help page.  
 (ii) Write an HTML program for preparing the webpage for help.
6. (a) Hydro power plants are used to generate considerable amount of energy requirement in Sri Lankan power system.  
 (i) A hydropower plant can be categorised based on water head as low, medium and high head plants. Name suitable turbine types for each type.  
 (ii) Name the **four** main components of a large hydropower station with a reservoir.
- (b) High voltages are used in transmitting power in long distances. Transformers are used to step up and step down voltages for this purpose.  
 (i) Give a reason for using high voltages for transmitting power.  
 (ii) Three windings of the three phases in a three-phase transformer (in primary or secondary) are connected in two ways. What are those **two** ways? Explain the **two** methods with illustrations.  
 (iii) List **three** three-phase transformer types based on winding connections of the primary and secondary as identified in part (ii) above.

Department of Examinations, Sri Lanka.

Department of Examinations, Sri Lanka.