

AL/2020/14/E-I (NEW/OLD)

සියලු ම හිමිකම් ඇවිරිණි / முழுப் பதிப்புரிமையுடையது / All Rights Reserved

නව/පැරණි නිර්දේශය - புதிய/பழைய பாடத்திட்டம் - New/Old Syllabus

NEW/OLD

ශ්‍රී ලංකා විභාග දෙපාර්තමේන්තුව
இலங்கைப் பரீட்சைத் திணைக்களம்
Sri Lanka Department of Examinations, Sri Lanka

අධ්‍යයන පොදු සහතික පත්‍ර (උසස් පෙළ) විභාගය, 2020
கல்விப் பொதுத் தராதரப் பத்திர (உயர் தர)ப் பரீட்சை, 2020
General Certificate of Education (Adv. Level) Examination, 2020

සිවිල් තාක්ෂණවේදය I
குடிசார்த் தொழினுட்பவியல் I
Civil Technology I

14 E I

පැය දෙකයි
இரண்டு மணித்தியாலம்
Two hours

Instructions:

- * Answer all the questions.
- * Write your **Index Number** in the space provided in the answer sheet.
- * Instructions are given on the back of the answer sheet. Follow them carefully.
- * In each of the questions 1 to 50, pick one of the alternatives from (1), (2), (3), (4), (5) which is **correct** or **most appropriate** and mark your response on the answer sheet with a cross (x) in accordance with the instructions given in the back of the answer sheet.
- * Use of calculators is not allowed.

1. Select the symbol which denotes the NPN transistor.

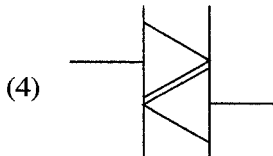
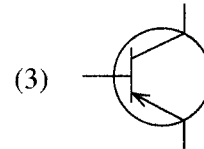
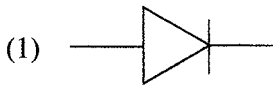

2. What is the nominal frequency of the domestic electricity supply in Sri Lanka?

- (1) 49.5 Hz (2) 50 Hz (3) 50.5 Hz (4) 55 Hz (5) 60 Hz

3. Mercury has a Specific Gravity of 13.6. The pressure exerted at the bottom of a 700 mm long mercury column is equal to (consider $g = 9.81 \text{ m s}^{-2}$)

- (1) 1 atm. (2) 100 kN. (3) 100 kPa. (4) 93391 Pa. (5) 101396 Pa.

4. A ball is dropped from the top of a tall building. Which of the following acceleration-time graph shows the motion of the ball in air? (Assume that there is no air resistance.)

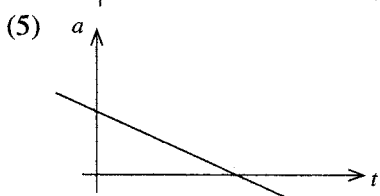
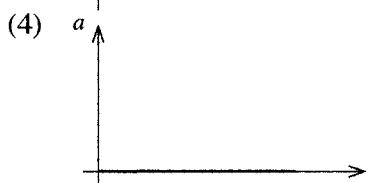
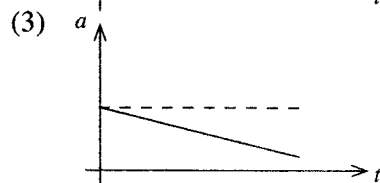
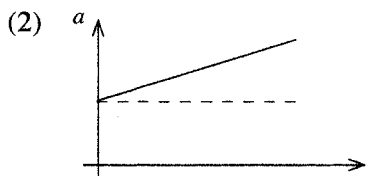
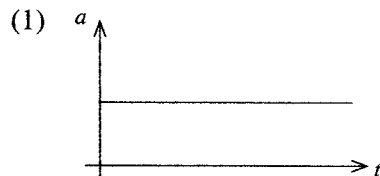

9. What is the resistance between points A and B in the following circuit?

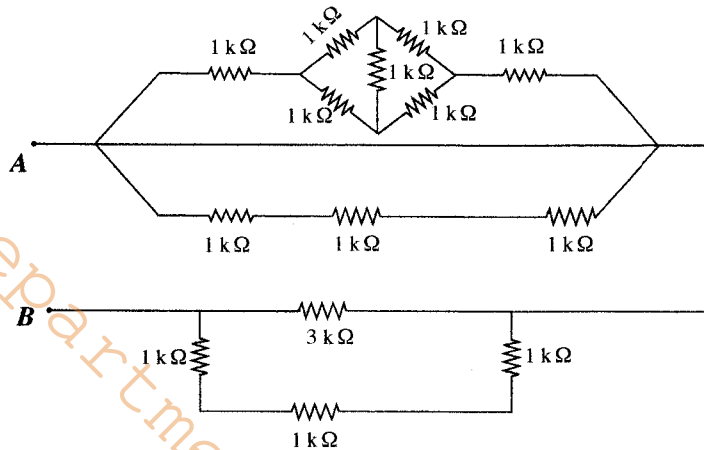

- (1) 1.5 kΩ (2) 3 kΩ (3) 6 kΩ (4) 9 kΩ (5) 12 kΩ

10. Consider the following graphs.

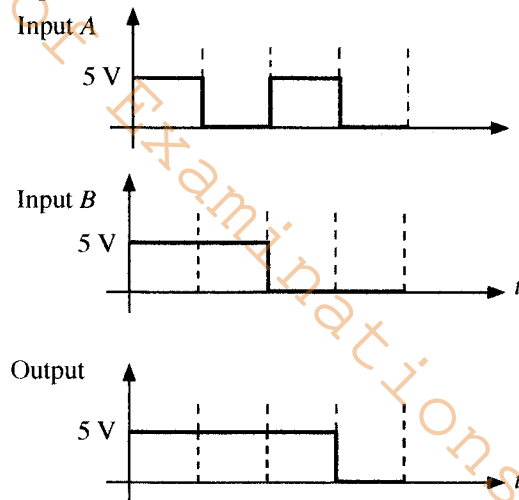

Above logic output was observed when Input A and Input B are connected to its inputs of a logic gate. Here 5 V and 0 V voltage represent logic '1' and logic '0', respectively.

Identify the logic gate referring the above graphs.

- (1) AND (2) OR (3) NOT (4) NOR (5) NAND

11. A 100 kg mass is hanging in a frictionless pulley system as shown in the figure. The force in Newton to be applied at the free end (P) in order to keep the system stable is (Neglect the weight of the pulleys, consider acceleration due to gravity ($g = 9.81 \text{ m s}^{-2}$))

- (1) 10g. (2) 25g. (3) 33g.
(4) 50g. (5) 100g.

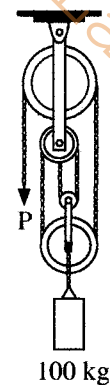

12. Which one shows correct view when projected from direction A?

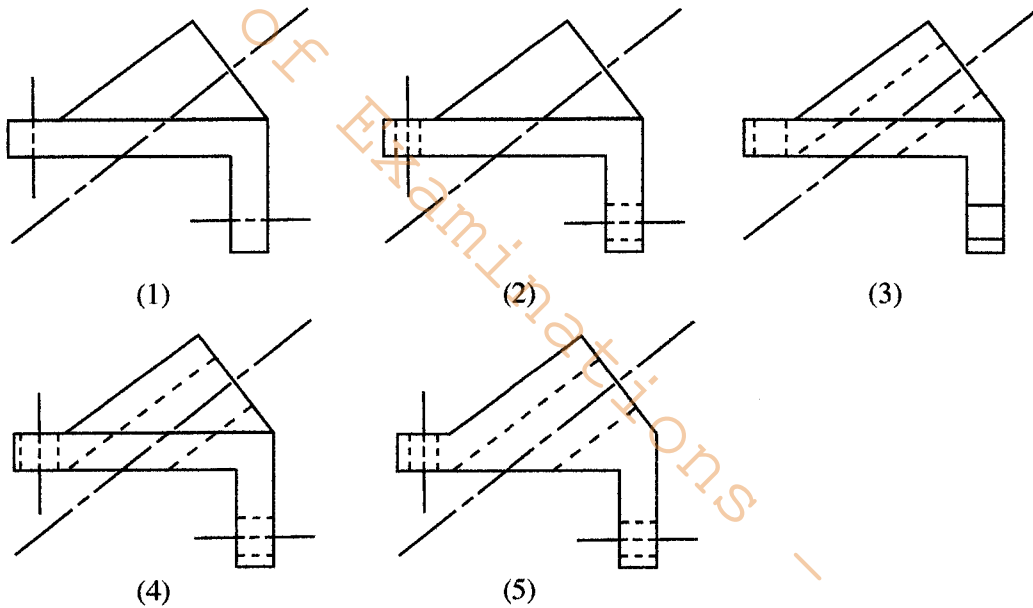
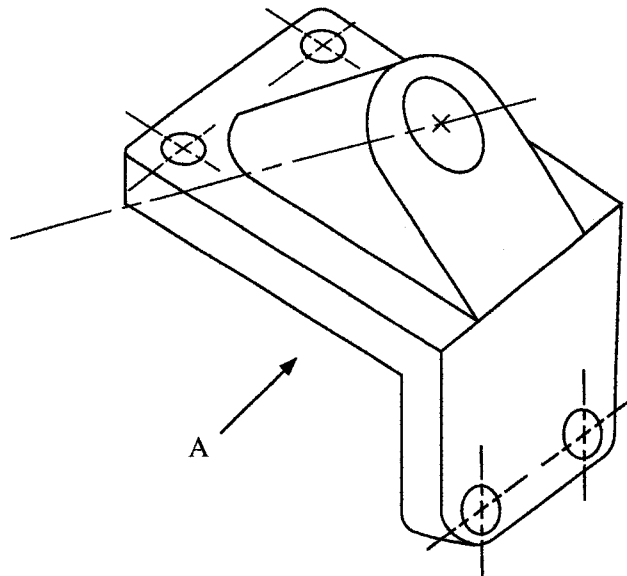

13. Figure shows a Baltimore truss structure used in a bridge. Following gives some statements of the truss structure.

- A - LE member force is more than 5 kN.
- B - Member forces in ML and LK are compressive.
- C - Member forces in lower chord are tensile.
- D - Member NB and NC increase safety of truss structure.

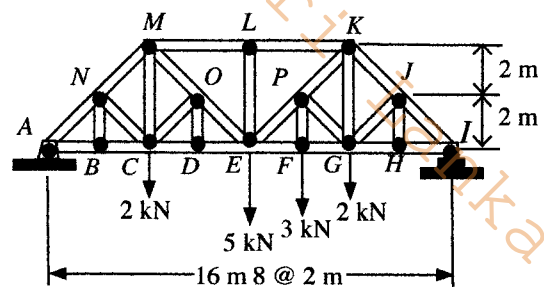

Out of the above statements, the correct statements are,

- (1) A, B and C only.
- (2) A, B and D only.
- (3) A, C and D only.
- (4) B, C and D only.
- (5) A, B, C and D all.

14. Consider the following statements regarding a typical Brass screw used in a common door hinge which is shown in the figure.

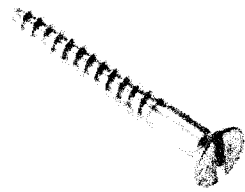

- A - Tapered shape helps it to be screwed in, using a screwdriver.
- B - The screw is held tight by the frictional resistance of the helical thread.
- C - The screw shaft is expected to provide a tensile resistance.
- D - The screw shaft is expected to carry the force due to the weight of the door.

Which of the above statements are true regarding its use?

- (1) A, B and C only.
- (2) A, B and D only.
- (3) A, C and D only.
- (4) B, C and D only.
- (5) A, B, C and D all.

15. Consider the following statements.

- A. Fine carbon particles in human lungs cause respiratory issues.
- B. Mercury accumulation in fish.
- C. Accumulation of heavy metals in fly-ash heaps due to burning of coal.
- D. Motor vehicle emissions building up in birds.

Which of the above statements describe the effects of bioaccumulation?

- (1) A, B and C
- (2) A, B and D
- (3) A, C and D
- (4) B, C and D
- (5) A, B, C and D

16. The figure shows an isometric view of a bar holder bracket. What are the correct orthographic projections when viewed from arrows A and B respectively?

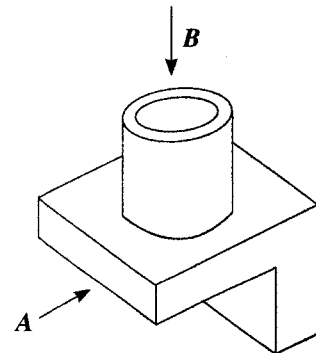

 (1)	 (2)	 (3)	 (4)	 (5)
---------	---------	---------	---------	---------

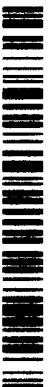

17. 800 N weight rod AB positioned as shown in the figure. The contact surface at B is smooth, whereas the coefficient of static friction (between the rod and the wall) at A is 0.2. The minimum force P to prevent rod AB from sliding is

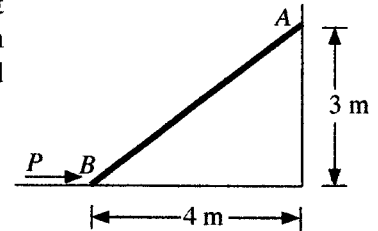

- (1) 221 N. (2) 321 N. (3) 421 N.
 (4) 433 N. (5) 533 N.

18. Consider the following statements.

- A - When using a meter ruler to measure a length, the smallest estimate is 0.0005 m.
 B - The SI unit for measuring energy is Calorie.
 C - Candela (Cd) is the SI unit for luminous cell voltage of 1.5 V.
 D - Zinc-carbon AA type batteries have a nominal cell voltage of 1.5 V.

Which of the above statements are true?

- (1) A, B and C only. (2) A, B and D only. (3) A, C and D only.
 (4) B, C and D only. (5) A, B, C and D all

19. Consider the following statements.

- A - Switch off the power supply to the motor prior to mounting or removing accessories.
 B - Ensure that the emergency stop button is functioning.
 C - The floor should be clean and non-slippery.
 D - Reduce rotating speed when taking measurements.

Which of the above statements describe safety measures when operating a lathe machine?

- (1) A, B and C only. (2) A, B and D only. (3) A, C and D only.
 (4) B, C and D only. (5) A, B, C and D all.

20. Consider the following statements.

- A - Varnish used to preserve timber may consist of natural resins that dissolve in turpentine.
 B - Aluminium Sulphate is a flocculating agent used to remove suspended solids in water.
 C - Silica is the main ingredient used when manufacturing glass.
 D - When gluing two objects, high surface roughness causes good bonding.

Which of the above statements are true regarding the use of chemical compounds?

- (1) A, B and C only. (2) A, B and D only. (3) A, C and D only.
 (4) B, C and D only. (5) A, B, C and D all.

21. A player hits a tennis ball of mass 150 g with a racket. It changes its velocity as shown in the figure. What is the momentum increase?

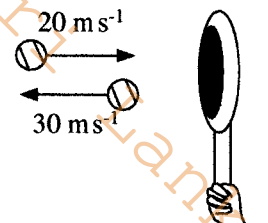

- (1) 1.5 kg m s⁻¹ (2) 2.5 kg m s⁻¹ (3) 5.5 kg m s⁻¹
 (4) 7.5 kg m s⁻¹ (5) 10.0 kg m s⁻¹

22. Consider the following statements.

- A - Ability to track the order and stating the delivery date.
 B - Providing product information, availability in stock, price and alternatives.
 C - Providing customer reviews on products.
 D - Reduced transaction time and associated costs.

Which of the above statements describe entrepreneurship traits of a reputable online shopping enterprise?

- (1) A, B and C only. (2) A, B and D only. (3) A, C and D only.
 (4) B, C and D only. (5) A, B, C and D all.

[See page seven

23. Consider the following circuit. To this circuit ideal ammeters are connected and their readings are M_1 , M_2 , M_3 and M_4 .

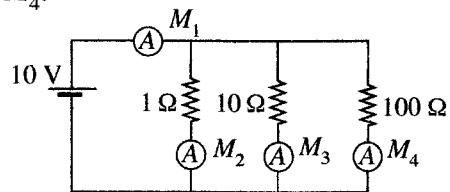

Which of the following statement is **incorrect**?

- (1) Value of $M_1 = M_2 + M_3 + M_4$
 - (2) Value of $M_3 = 1$ A
 - (3) M_4 is the smallest reading.
 - (4) M_1 is the largest reading.
 - (5) Value of $M_1 > (M_2 + M_3 + M_4)$
24. Ten 5 W LED bulbs are used in a house. Each bulb is lit for 5 hours, daily. What is the daily electrical energy consumption?
- (1) 0.025 kW h
 - (2) 0.25 kW h
 - (3) 2.5 kW h
 - (4) 25 kW h
 - (5) 250 kW h
25. Which statement correctly explains the reason for faster corrosion of a steel structure in coastal areas?
- (1) The coastal areas do not have sufficient trees to provide oxygen.
 - (2) The wind in the coastal areas contains salt which accelerates corrosion.
 - (3) Extreme heat in coastal areas cause the rapid corrosion.
 - (4) High solar irradiation in coastal areas accelerates corrosion.
 - (5) Tidal waves of the sea affect rapid corrosion of steel.
26. Consider the following statements.
- A - Load bearing walls transmit the weight of super-structure to the foundation base.
 - B - Non-load-bearing walls transmit its self-weight to the foundation base.
 - C - A thin hollow block wall can be made a load-bearing wall by filling the cavities with concrete.
 - D - Load bearing walls may transmit the weight of the super-structure on to a beam.
- Which of the above statements are true regarding load-bearing and non-load bearing walls?
- (1) A, B and C only.
 - (2) A, B and D only.
 - (3) A, C and D only.
 - (4) B, C and D only.
 - (5) A, B, C and D all.
27. Consider the following statements.
- A - It acts as a carbon sink which reduces atmospheric carbon dioxide.
 - B - It acts as a flood control reservoir thereby reducing the potential for flooding.
 - C - It acts as a storm and wind buffer by dissipating energy.
 - D - It acts as a pollution filter against coastal contamination.
- Which of the above statements describe the benefits of having marshy areas in a coastal peneplane?
- (1) A, B and C only.
 - (2) A, B and D only.
 - (3) A, C and D only.
 - (4) B, C and D only.
 - (5) A, B, C and D all.
28. Consider the following statements.
- A - Evapotranspiration from the reservoir surface reduces water availability for cultivation.
 - B - Water infiltration in the reservoir bed increases with pressure head.
 - C - Siltation is more when the catchment area is unprotected.
 - D - Dead storage is the volume of water that cannot be distributed efficiently under gravity.
- Which of the above statements describe processes in an artificial reservoir?
- (1) A, B and C only.
 - (2) A, B and D only.
 - (3) A, C and D only.
 - (4) B, C and D only.
 - (5) A, B, C and D all.

29. Bulking of sand is caused due to

- (1) surface moisture. (2) air voids. (3) viscosity.
(4) surface texture. (5) grain size.

30. Five members of steel sections shown below has the same cross-sectional area. Which section is the most efficient steel section to be used in a column?

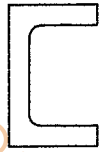

Channel section

(1)

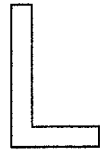

Angle section

(2)

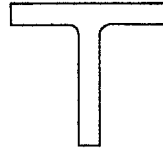

T section

(3)

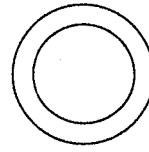

Circular hollow section

(4)

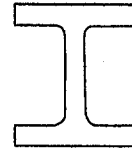

Rolled steel joister section

(5)

31. Inner part of a timber log surrounding the pith, is called

- (1) sapwood. (2) heart wood. (3) cambium layer.
(4) medullary rays. (5) phloem.

32. The equipment shown in the figure is used to determine the

- (1) compressive strength of concrete.
(2) concrete slump.
(3) setting time of cement.
(4) water cement ratio.
(5) bulking of sand.



33. The built-up area of a building as defined in building By-laws is the total area of

- (1) the ground floor.
(2) all floors above and below ground level.
(3) ground floor excluding the area of porch.
(4) all floors above and below ground level excluding roof top area.
(5) all floors including ground floor excluding roof top area.

34. An 'all in' labour rate is

- (1) calculation of total operative costs.
(2) rate of pay an operative receives.
(3) tax and deductions charged from an operative's wage.
(4) cost of welfare provided to operatives.
(5) cost of paid leave to operatives.

35. The purpose of a cavity in a cavity wall is to

- (1) allow space to install a DPC.
(2) give strength to the building walls.
(3) prevent moisture penetrating into the building.
(4) increase the wall thickness.
(5) prevent vermin entering the building.

36. A suspended floor consists of a

- (1) Pre-cast block and beams. (2) Solid concrete. (3) Laminate.
(4) Pile and ring beams. (5) Cast in situ beams and slab.

[See page nine

37. Three types of drill bits are shown below.

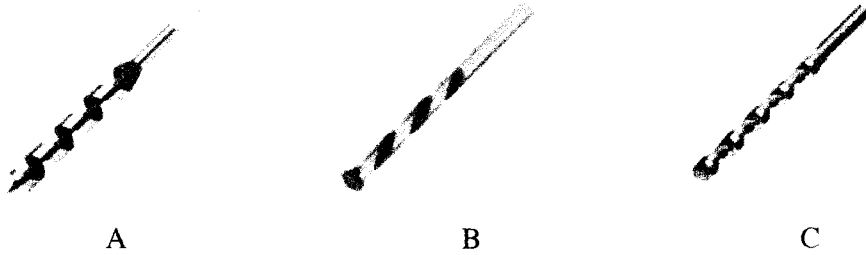

Figures A, B and C, respectively, show

- (1) Masonry bit, Auger bit and High speed steel drill bit.
 - (2) Auger bit, Masonry bit and High speed steel drill bit.
 - (3) High speed steel drill bit, Masonry bit and Auger bit.
 - (4) Auger bit, High speed steel drill bit and Masonry bit.
 - (5) Masonry bit, High speed steel drill bit and Auger bit.
38. The depth of an arch is the distance between the
- (1) ground level and springing line.
 - (2) crown and springing line.
 - (3) crown and ground level.
 - (4) crown and skewback.
 - (5) intrados and extrados.
39. The platform at the end of a series of steps in a stairway is called
- (1) a stop. (2) a rest. (3) a relief. (4) a landing. (5) a tread.
40. A level line is a
- (1) horizontal line between two points.
 - (2) plumb line between two points.
 - (3) line parallel to the mean spherical surface of earth.
 - (4) line passing through center of cross hairs and the center of eye piece.
 - (5) line passing through the objective lens and the eye piece of a levelling instrument.
41. From the traps shown below, the most suitable trap for a kitchen wash basin is,

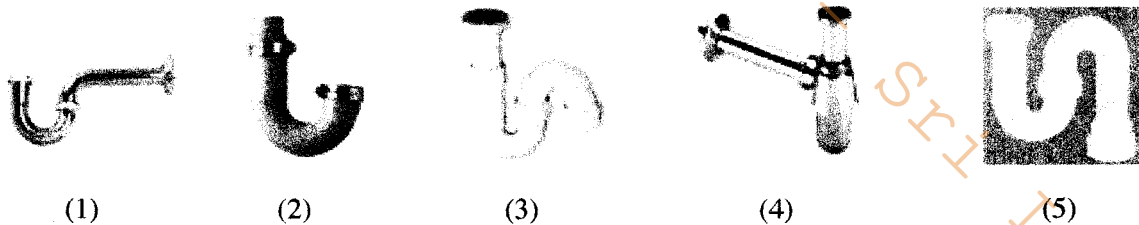

42. BOD for treated pipe-born water of potable quality should be
- (1) 0 ppm. (2) 10 ppm. (3) 50 ppm. (4) 100 ppm. (5) 150 ppm.
43. The two main causes of hardness in water is due to the presence of
- (1) gold and silver. (2) calcium and magnesium.
 (3) phosphate and nitrate. (4) oxygen and methane. (5) chlorine and alum.
44. The valve used to prevent water flowing in the opposite direction is a
- (1) Gate valve. (2) Stop valve. (3) Check valve. (4) Ball valve. (5) Globe valve.

45. Three types of valves used in water supply are shown below.

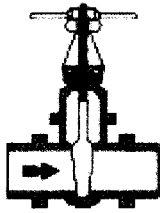

A



B



C

Figures A, B and C, respectively, are

- (1) Float valve, Ball valve and Gate valve.
- (2) Gate valve, Ball valve and Float valve.
- (3) Ball valve, Gate valve and Float valve.
- (4) Gate valve, Float valve and Ball valve.
- (5) Ball valve, Float valve and Gate valve.

46. Damaged power cables on portable tools must be

- (1) replaced.
- (2) taped.
- (3) soldered and taped.
- (4) spliced and taped.
- (5) twist jointed and taped.

47. The two most important safety concerns when entering a confined space is due to the presence of

- (1) corrosive chemicals and falls.
- (2) bad odours and claustrophobia.
- (3) extreme air temperatures and slippery surfaces.
- (4) oxygen deficiency and hazardous gasses.
- (5) poor light and insects.

48. Figure shows the elevation view of a road section. The respective elevations of the edge of the shoulder and the bottom of the ditch are,

- (1) 7499.6' and 7495.6'
- (2) 7504.0' and 7508.0'
- (3) 7496.0' and 7498.0'
- (4) 7496.6' and 7495.6'
- (5) 7499.6' and 7498.6'

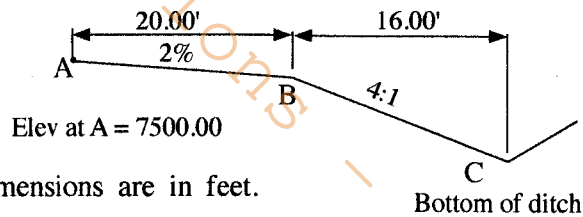

49. Linear method is one of the methods used in setting out a road curve.

- A. Chain B. Tape C. Theodolite D. Compass

Which of the above surveying instruments can be used in the linear method of curve setting?

- (1) A, B and C only.
- (2) A, B and D only.
- (3) A, C and D only.
- (4) B, C and D only.
- (5) A, B, C and D all.

50. Road shoulder is an integral part of a road section, provided at the road edge. A shoulder should be

- (1) rougher than the traffic lane.
- (2) smoother than the traffic lane.
- (3) having same roughness as the traffic lane.
- (4) of very low load bearing value.
- (5) of same colour that of the traffic lane.

* * *

සියලු ම හිමිකම් ඇවිරිණි / முழுப் பதிப்புரிமையுடையது / All Rights Reserved

නව/පැරණි නිර්දේශය - புதிய/பழைய பாடத்திட்டம் - New/Old Syllabus

NEW/OLD

ශ්‍රී ලංකා විභාග දෙපාර්තමේන්තුව ශ්‍රී ලංකා විභාග දෙපාර්තමේන්තුව ශ්‍රී ලංකා විභාග දෙපාර්තමේන්තුව ශ්‍රී ලංකා විභාග දෙපාර්තමේන්තුව ශ්‍රී ලංකා විභාග දෙපාර්තමේන්තුව
இலங்கைப் பரீட்சைத் திணைக்களம் இலங்கைப் பரීட்சைத் திணைக்களம் இலங்கைப் பரීட்சைத் திணைக்களம் இலங்கைப் பரීட்சைத் திணைக்களம் இலங்கைப் பரීட்சைத் திணைக்களம்
Sri Lanka Department of Examinations, Sri Lanka Department of Examinations, Sri Lanka Department of Examinations, Sri Lanka Department of Examinations, Sri Lanka Department of Examinations, Sri Lanka
இலங்கைப் பரීட்சைத் திணைக்களம் இலங்கைப் பரීட்சைத் திணைக்களம் இலங்கைப் பரීட்சைத் திணைக்களம் இலங்கைப் பரීட்சைத் திணைக்களம் இலங்கைப் பரīட்சைத் திணைக்களம்

අධ්‍යයන පොදු සහතික පත්‍ර (උසස් පෙළ) විභාගය, 2020
கல்விப் பொதுத் தராதரப் பத்திர (உயர் தர)ப் பரீட்சை, 2020
General Certificate of Education (Adv. Level) Examination, 2020

සිවිල් තාක්ෂණවේදය II
குடிசார்த் தொழினுட்பவியல் II
Civil Technology II

14 E II

පැය තුනයි
மூன்று மணித்தியாலம்
Three hours

අමතර කියවීමේ කාලය - මිනිත්තු 10 යි
மேலதிக வாசிப்பு நேரம் - 10 நிமிடங்கள்
Additional Reading Time - 10 minutes

Use additional reading time to go through the question paper, select the questions you will answer and decide which of them you will prioritise.

Index No. :

Important :

- * This question paper consists of 12 pages.
- * This question paper comprises Parts A, B and C. The time allotted for all parts is three hours. (Use of calculators is not allowed.)

Part A - Structured Essay (08 pages)

- * Answer all the questions on this paper itself.
- * Write your answers in the space provided for each question. Note that the space provided is sufficient for your answers and that extensive answers are not expected.

Part B and C - Essay (04 pages)

- * Select two questions from each of the parts B and C and answer four questions only. Use the papers supplied for this purpose. At the end of the time allotted for this paper, tie the three parts together so that Part A is on the top of Part B and C before handing over to the supervisor.
- * You are permitted to remove only Parts B and C of the question paper from the Examination Hall.

For Examiner's Use Only

Part	Q. No.	Marks
A	1	
	2	
	3	
	4	
B	5	
	6	
	7	
C	8	
	9	
	10	
Total		
Percentage		

Final Marks

In Numbers	
In Words	

Code Numbers

Marking Examiner 1	
Marking Examiner 2	
Checked by	
Supervised by	

PART A – Structured Essay
 Answer *all four* questions on this *paper itself*.
 (Each question carries 10 marks)

Do not
 write
 in this
 column

1. The diagram shows an isometric view of a bracket made of light steel. The bracket is symmetric along the vertical plane passing through X-X. Assuming any missing dimensions draw the following views to a suitable scale using first angle projection principles. Show all relevant dimensions in the sketches. Use the graph sheets given on page 3 and 4 to answer the questions. (All dimensions are in millimetres.)

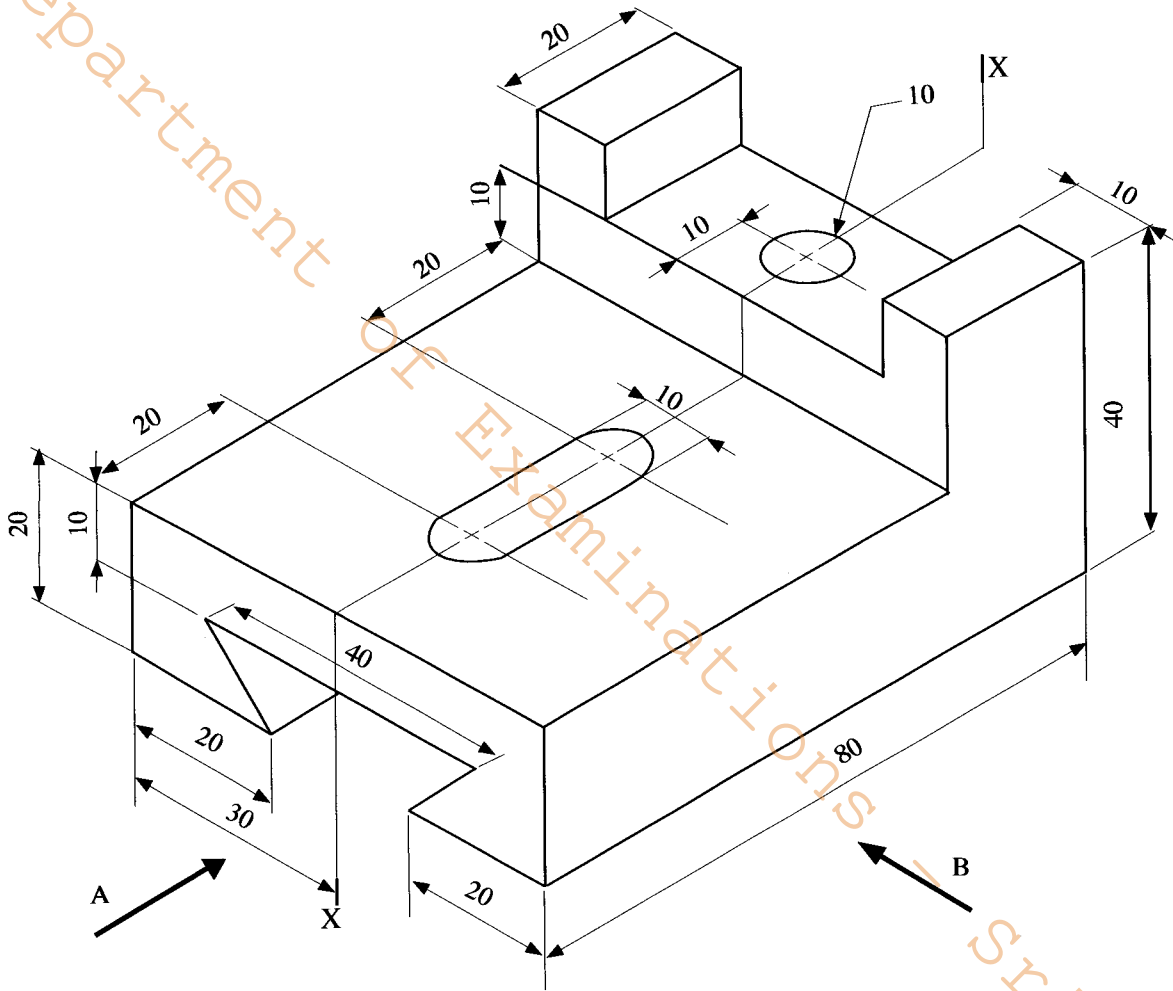

- (i) Front elevation seen through direction A
 (ii) End elevation seen through direction B
 (iii) Plan

DEPARTMENT OF
OK
SCHOOL EXAMINATIONS
SCHOOL
SCHOOL

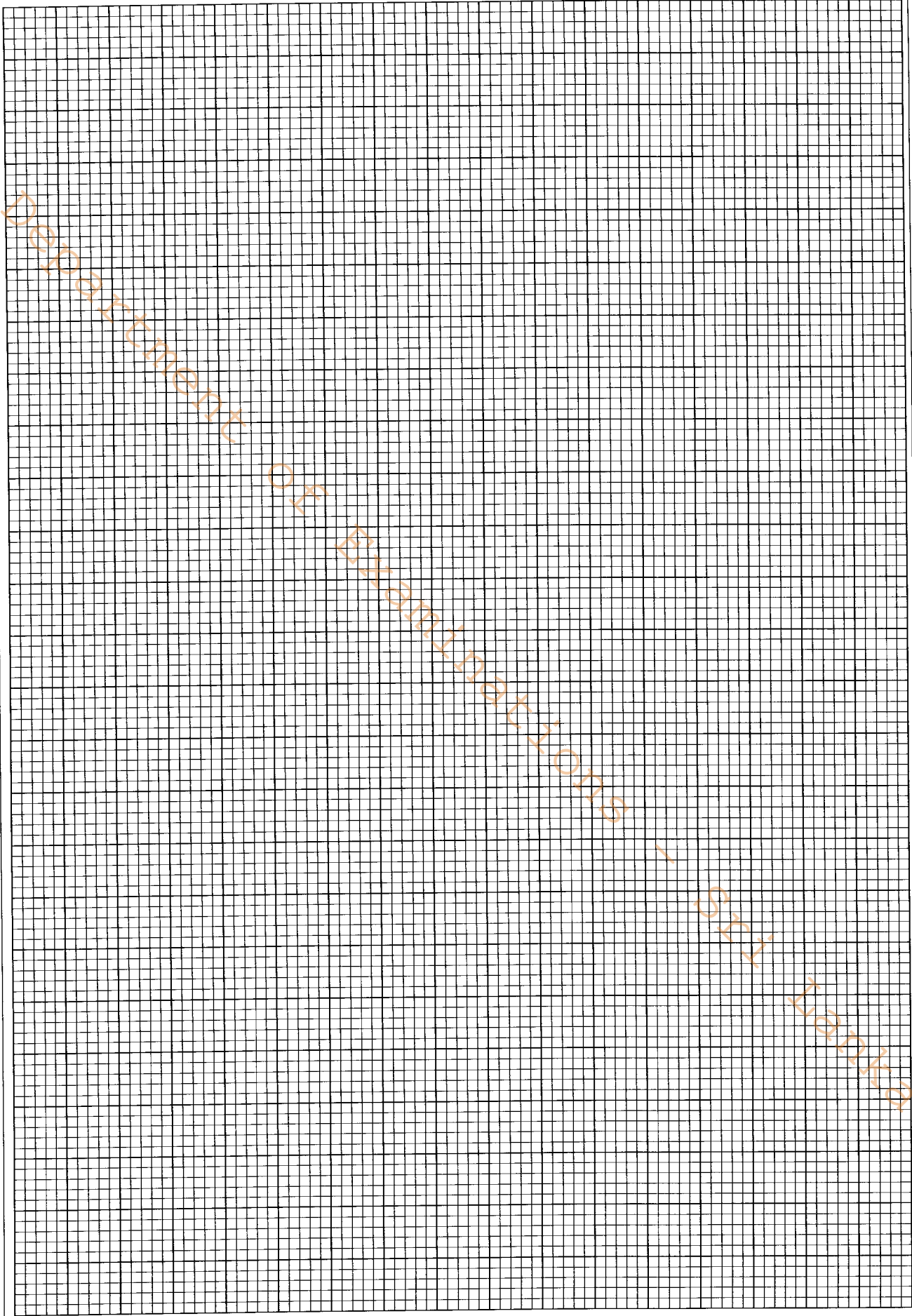

Do not write in this column

2. Assume that you are assigned to develop the Information Technology (IT) infrastructure for conducting online classes for a school during Covid-19 pandemic. The requirements are given below.

- * A recording room to record video lessons to be uploaded to the school website.
- * A room for teachers to conduct online classes, in realtime. Students should be able to participate in the classes interactively.
- * Computer station to prepare teaching materials, e.g. power point slide presentations.
- * Use of online storage and online documents during classes.

Assume that the school administration is designing a room with IT facilities.

(a) There are stations with desktop computers (main central processing unit-CPU, monitor, keyboard and mouse) in the room.

(i) Write **two** additional hardware items required for each station.

.....

.....

.....

(ii) Name **one** software item that can be used to conduct and record online classes, in realtime.

.....

(b) (i) Name **two** additional hardware items required by students to connect with online classes in realtime.

.....

.....

.....

(ii) List **one** facility required for students in addition to the hardware items mentioned in (b)(i) above, to connect with online classes.

.....

.....

(c) If the learning activities require students to interactively prepare a group project report online, suggest one online facility that they could use for this purpose.

.....

.....

(d) A teacher has requested a method to share additional reading materials with students. State **two** ways you would suggest to fulfill this purpose.

.....

.....

.....

Do not write in this column

3. Figure shows the layout of a single-story laboratory building of a school. This facility is used by all the students in the Science Stream.

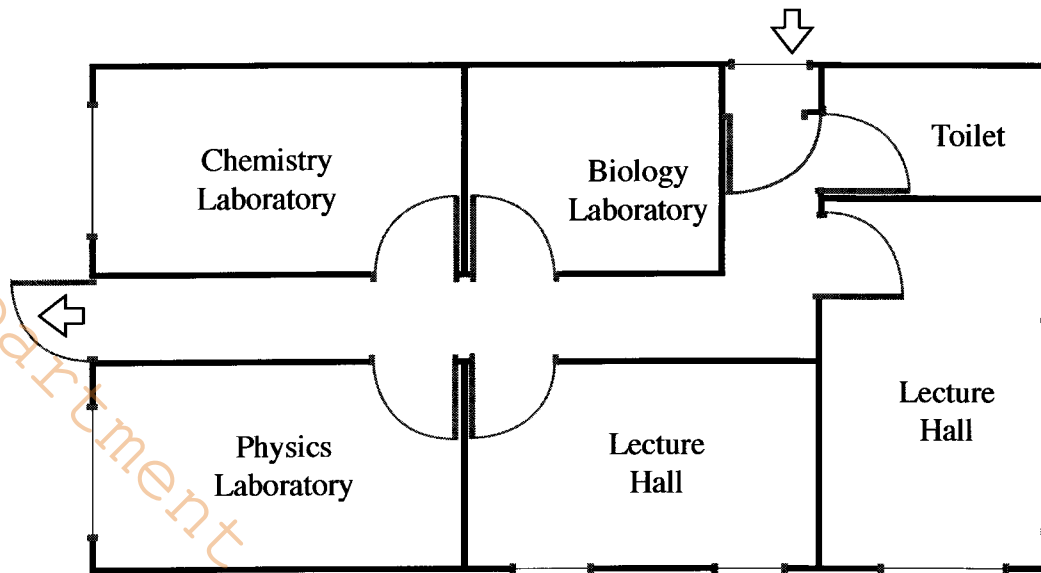

Legend:

(i) Explain the basis for the selection of locations for fire extinguishers in this building. Mark these locations in the building layout. Use a suitable symbol to identify these locations; Show the symbol in the legend.

.....
.....
.....
.....

(ii) Explain the basis for the selection of locations for hardwired smoke detecting devices in this building. Mark these locations in the building layout. Use a suitable symbol to identify these locations; Show the symbol in the legend.

.....
.....
.....
.....

Do not write in this column

(iii) Explain the basis for the selection of locations to install the first-aid boxes in this building. Mark these locations in the building layout. Use a suitable symbol to identify these locations; show the symbol in the legend.

.....
.....
.....
.....

(iv) Explain the basis for the selection of a communication method in an emergency. Show the communication equipment and accessories on the building layout. Use suitable symbols to identify these; show the symbol in the legend.

.....
.....
.....
.....

(v) State occupational health and safety measures to be incorporated in the Chemistry laboratory.

.....
.....
.....
.....



4. Figure shows a foot operated valve, which supplies water to a sink. When the foot pedal is made to slide forward horizontally (refer figure B) the ball valve is made to open via a simple lever mechanism connected to its axis of rotation. When the foot pedal is made to slide backwards the valve closes.

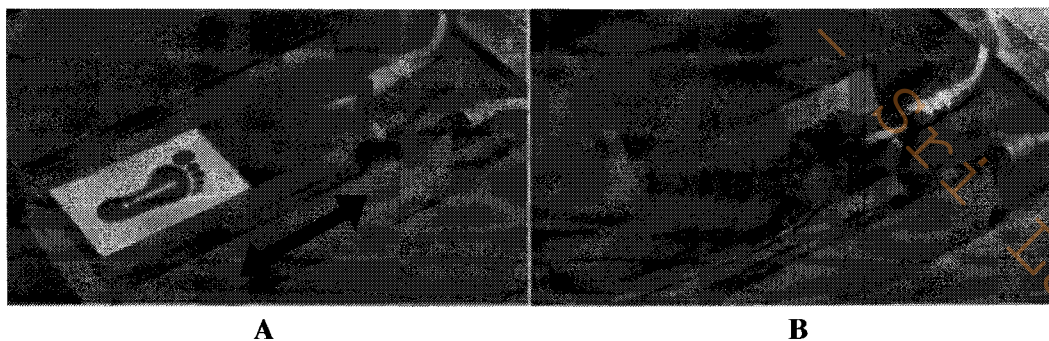

Fig. Foot operated valve <http://www.youtube.com/watch?v=bIPxSMUsqyA>

(a) Show a schematic view of the ball valve; show how it opens and closes during the movement of the foot pedal.

Do not write in this column

(b) Show a schematic view of the lever mechanism which gives the desired rotation to the ball valve axis.

(c) Describe the merits of this innovation.

.....
.....
.....
.....

(d) Mention the shortcomings of this innovation.

.....
.....
.....
.....
.....

* *



Department Of Examinations - Sri Lanka

(e) Describe **two** benefits for Sri Lanka in using solar PV plants.

7. Generation and unsafe disposal of plastic waste is an ongoing issue in Sri Lanka. Even though we use 'safe' plastics to wrap food, being poly-carbonate compounds, they tend to bond with harmful chemicals in unregulated disposal sites. The leachate (i.e. liquid waste) and micro-plastics produced tend to contaminate surface and groundwater bodies, and the marine environment. These pollutants enter the food chains of human beings and animals.

Figure shows the classification system developed by the Society of Plastic Industry, in 1988.

WHAT DO RECYCLING SYMBOLS ON PLASTICS MEAN?



PET, PETE
(Polyethylene Terephthalate)
● Soft drink, water and salad dressing bottles, peanut butter and jam jars...
● Suitable to store cold or warm drinks. Bad idea for hot drinks.



PP
(Polypropylene)
● Reusable microwaveable ware kitchenware, yogurt containers, microwaveable disposable take-away containers, disposable cups, plates...



HDPE
(High-density Polyethylene)
● Water pipes, milk, juice and water bottles, grocery bags, some shampoo/toiletry bottles...



PS
(Polystyrene)
● Egg cartons, packing peanuts, disposable cups, plates, trays and cutlery, disposable take away containers...
A void for food storage!



PVC
(Polyvinyl Chloride)
● Not used for food packaging
● Pipes, cables, furniture, cloths, toys...



Other
(Often Polycarbonate or ABS)
● Beverage bottles, baby milk bottles compact discs, "unbreakable" glazing, lenses including sunglasses, prescription glasses, automotive headlamps, riot shields, instrument panels...



LDPE
(Low-density Polyethylene)
● Frozen food bags, squeezable bottles, e.g. honey, mustard, cling films, flexible container lids...

<http://nowsaveouplanet.blogspot.com/2015/07/what-types-of-plastics-can-be-recycled.html>

The recycling rates of each type reduces with ascending numbers. This depends on the usage, the collection, the technology and the cost of processing of each type. The recycled products should also be used as a raw material for another finished product. The recycling percentage of each type in the developed world is around 20-40%. A small portion is burnt to produce energy, many end up in regulated and unregulated landfills, waste dumps, or in the sea.

- (i) Classify the different types of waste produced in your local government (Pradesheeya Sabha, Urban council or Municipal Council) division, based on the above classification.
- (ii) Propose to your local government institution as to how they should handle the different types of wastes. Identify their respective cost implications to the community.
- (iii) Discuss **three** strategy to influence your community to use alternate non-plastic products or to reduce plastic usage significantly.

Part C

8. Figure shows the sectional view and the plan view of a cylindrical overhead water storage tank made of reinforced concrete with 100 mm thick wall. It has a concrete base and cover 100 mm and 75 mm thick, respectively. Water supply to the tank is from the mains of the National Water Supply & drainage Board, through a 25 mm PVC pipe. The tank supplies water to a domestic household for its washrooms, kitchen, garden etc.

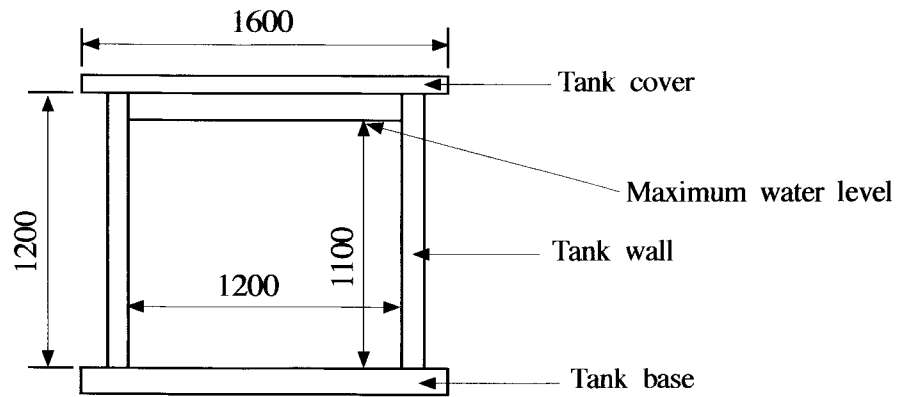
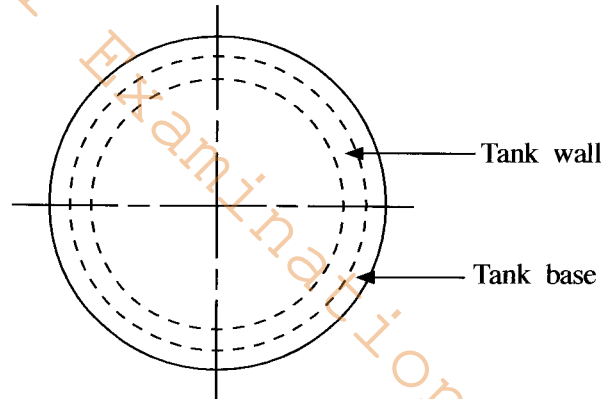
**SECTIONAL VIEW****PLAN**

(All dimensions in millimetres)

- (a) (i) Calculate the volume of water in litres that could be stored in the tank.
 (ii) Calculate the total volume of concrete required for the tank wall, tank base and tank cover.
 (iii) Show the connection locations, pipe sizes and names of all inlet and outlet pipes required for the tank.
 (iv) State the locations, types and sizes of all valves required for flow control.
 (v) Sketch the cross sectional view of any one of the valves you stated in (iv) above and explain how it functions.
- (b) Sketch the sectional view of a two chamber septic tank.
 (i) Name its parts and state their purpose.
 (ii) Describe how the septic tank functions.

9. Following figures show the plan and foundation detail of a small house. The pad foundation strip and plinth wall are made of random rubble masonry and the superstructure walls are made of cement blocks. Assume standard dimension for sizes when the dimension are not specified.

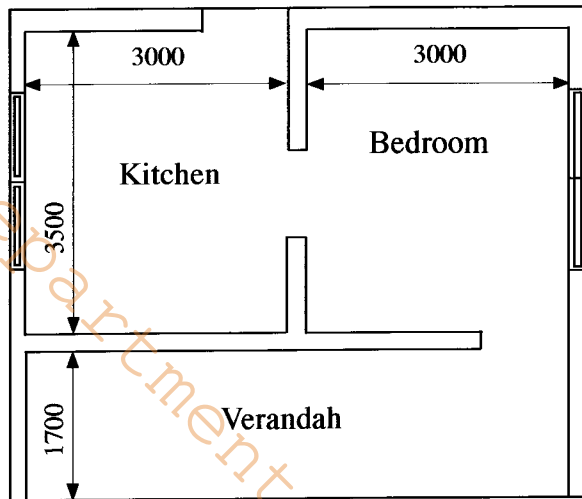

PLAN

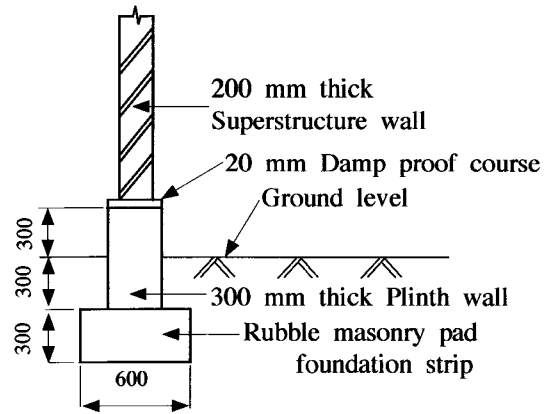

(All dimensions are in millimetres)

- (a) (i) Calculate the centreline length of superstructure walls in the building.
 (ii) Take off quantities for the excavation in foundation trenches.
 (iii) Take off quantities for random rubble work in pad foundation strip.
 (iv) Take off quantities for random rubble work in plinth wall.
 (v) Take off quantities for 20 mm thick damp proof course on top of plinth wall.
- (b) (i) State the elements of a unit rate.
 (ii) Differentiate between net unit rate and gross unit rate.
 (iii) List the cost items under each cost element for calculating the net unit rate and gross unit rate for mixing and placing 1m^2 of damp proof course on plinth wall.

10. The centre line levels of a road were checked at 11 points identified from points A to K in 20 m intervals for a 200 m length and following staff readings have been recorded. The Benchmark (B.M.) was 20.350 m above Mean Sea level and all the measurements are in meters.

From instrument Position 1: 2.455 (B.M.), 1.360 (A), 1.250 (B), 0.590 (C) and 0.690 (D)

From instrument Position 2: 1.745 (D), 1.530 (E), 1.320 (F) and 1.215 (G)

From instrument Position 3: 1.445 (G), 1.250 (H), 1.245 (I), 1.090 (J) and 0.890 (K)

- (i) Book the above readings in the standard form.
 (ii) Calculate the reduced levels of each centre point using rise and fall method.
 (iii) Apply relevant checks to verify your calculations.

* * *