

සියලු ම හිමිකම් ඇවිරිණි / முழுப் பதிப்புரிமையுடையது / All Rights Reserved]

ශ්‍රී ලංකා විභාග දෙපාර්තමේන්තුව
இலங்கைப் பரீட்சைத் திணைக்களம்
Department of Examinations, Sri Lanka

90 E I, II

අධ්‍යයන පොදු සහතික පත්‍ර (සාමාන්‍ය පෙළ) විභාගය, 2024(2025)
கல்வியப் பொதுத் தராதரப் பத்திர (சாதாரண தர)ப் பரீட்சை, 2024(2025)
General Certificate of Education (Ord. Level) Examination, 2024(2025)

නිර්මාණකරණය, විදුලිය හා ඉලෙක්ට්‍රොනික තාක්ෂණවේදය I, II
வடிவமைப்பும் மின் இலத்திரனியல் தொழினுட்பவியலும் I, II
Design, Electrical & Electronic Technology I, II

පැය තුනයි
மூன்று மணித்தியாலம்
Three hours

අමතර කියවීමේ කාලය - මිනිත්තු 10 යි
மேலதிக வாசிப்பு நேரம் - 10 நிமிடங்கள்
Additional Reading Time - 10 minutes

Use additional reading time to go through the question paper, select the questions and decide on the questions that you give priority in answering.

Design, Electrical & Electronic Technology I

Instructions:

- * Answer all questions.
- * In each of the questions 1 to 40, pick one of the alternatives (1), (2), (3), (4) which is correct or most appropriate.
- * Mark a cross (X) on the number corresponding to your choice in the answer sheet provided.
- * Further instructions are given on the back of the answer sheet. Follow them carefully.

1. If the sum of the interior angles of three geometrical figures are 180° , 360° and 540° , the geometrical figures matching for them respectively, are
 - (1) triangle, circle and pentagon.
 - (2) triangle, quadrilateral and hexagon.
 - (3) circle, quadrilateral and pentagon.
 - (4) semicircle, triangle and heptagon.
2. Consider the given below geometrical figure which is developed based on a hexagon with same sides.

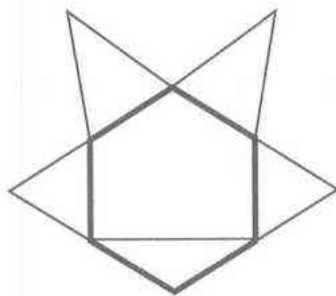

The figure includes

- (1) two equilateral triangles and three isosceles triangles.
 - (2) three equilateral triangles and two isosceles triangles.
 - (3) one equilateral triangle and three isosceles triangles.
 - (4) two scalene triangles and two equilateral triangles.
3. The radius of one circle is 40 mm and the radius of another circle is 30 mm. If these two circles are to be tangent at one point, the length of the line to be drawn equal to the length between the centers of those two circles is
 - (1) must be 40 mm.
 - (2) must be 60 mm.
 - (3) must be 70 mm.
 - (4) must be 80 mm.



4. A geometrical figure in which the construction lines are not shown, is given below.

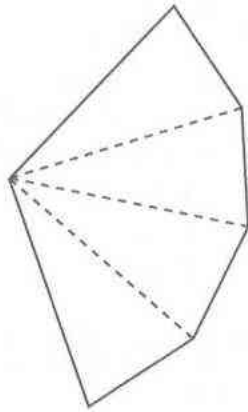

Above geometrical figure shows

- (1) a development of a prism in which the sides of the plan are equal in length.
 - (2) a development of a pyramid in which the sides of the plan are equal in length.
 - (3) a development of a tetrahedron in which the sides of the plan are equal in length.
 - (4) a development of a tetrahedron in which the sides of the plan are not equal in length.
5. What is the correct figure which shows the standard lines when drawn across the center of the circle included in the front view or the side view or the plan of orthogonal projections?

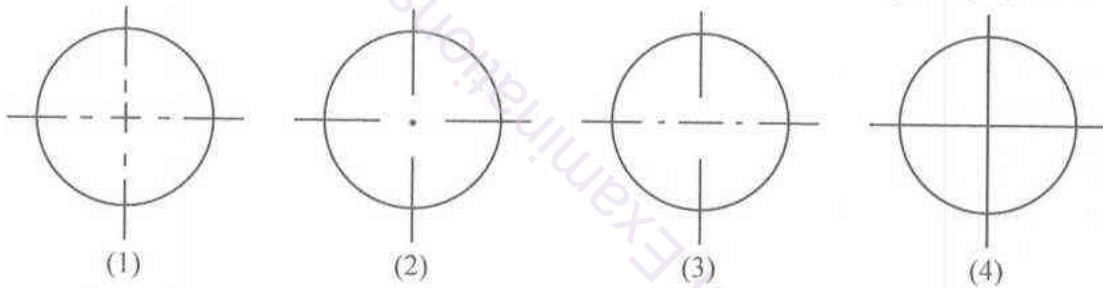

6. Some details of a geometrical figure are given below.

A – Opposite sides are equal.

B – Opposite angles are equal.

C – Though the diagonals are not equal in length, they bisect each other.

According to above details, this figure is

- (1) a rhombus. (2) a rhomboid. (3) a rectangle. (4) a trapezium.

7. Consider the following items.

A – A sheet tin

B – A cardboard box

C – A brick

D – A wooden block

E – A funnel

What are the items which can be developed out of the given above?

- (1) *A*, *B* and *C* only (2) *A*, *B* and *E* only
 (3) *A*, *B* and *D* only (4) *B*, *D* and *E* only
8. When piece of paper which has been cut in the shape of an equilateral triangle is divided into two symmetrically, the resultant figure is
- (1) an isosceles triangular shape.
 - (2) a scalene triangular shape.
 - (3) an equilateral triangular shape.
 - (4) a rectangular shape.

9. The standard colours of phase, neutral and earth conductors in three core wire which is used for a temporary extension code respectively are
 (1) brown, black and ash. (2) brown, blue and green/yellow.
 (3) red, black and green/yellow. (4) red, blue and green/yellow.
10. The main purpose of connecting a miniature circuit breaker to a circuit is
 (1) to protect the main switch.
 (2) personal safety.
 (3) to protect the cables of the house wiring circuit.
 (4) to protect the earth conductor.
11. The most suitable switch for personal safety in a domestic installation is
 (1) miniature circuit breaker. (2) isolator.
 (3) residual current circuit breaker. (4) two way switch.
12. An incident of receiving mechanical energy using electrical energy is
 (1) charging a battery by electric supply.
 (2) driving a vehicle by an engine.
 (3) operating a generator by an engine.
 (4) driving a small electric motor by a dry cell.
13. What is measured by an Electrical meter which fixed in a domestic installation?
 (1) Electric energy (2) Electric power
 (3) Time duration of electric energy intake (4) Maximum power
14. What is the percentage of direct current voltage having total rectified the output voltage of a stepdown transformer out of the square root mean value of transformer?
 (1) 45 (2) 50 (3) 90 (4) 100
15. DC voltage is needed to charge a lead acid battery. After AC rectification, a smoothing capacitor is **not** used here,
 (1) because it is unable to get required size capacitors.
 (2) because there are parallel plates with high capacitance value inside the battery.
 (3) because a ripple voltage is needed to charge the battery.
 (4) because capacitors are not needed to rechargeable batteries.
16. Which graph indicates the way of discharging with the time of a charged capacitor?

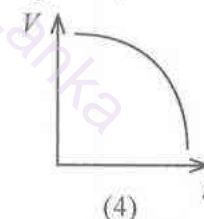
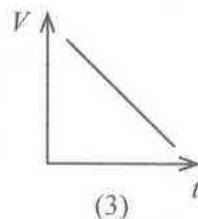
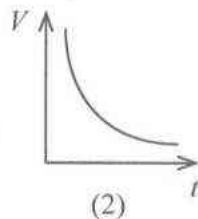
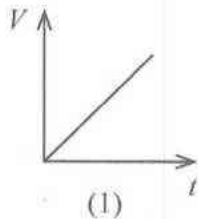

17. What is the equivalent capacitance of the below circuit?

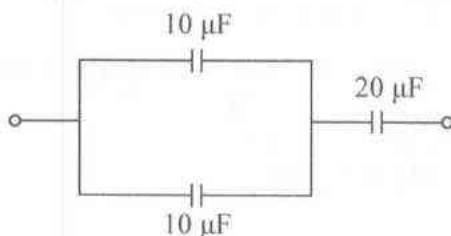

- (1) $10 \mu\text{F}$ (2) $20 \mu\text{F}$ (3) $30 \mu\text{F}$ (4) $40 \mu\text{F}$

40. The electricity supply for two types of electrical motors is provided through A and B circuits.

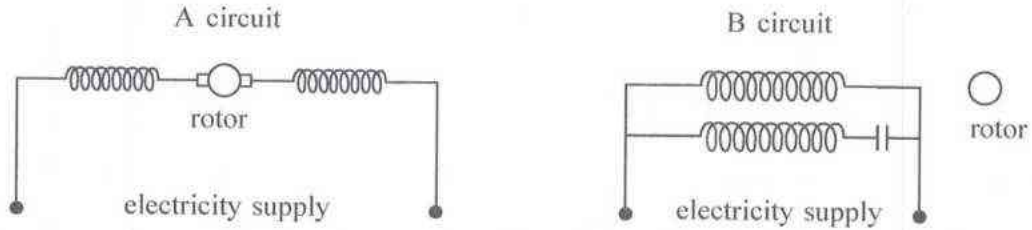

What is the correct way of supplying electricity for the two motor types given in the above circuit diagrams?

	A	B
(1)	DC current or AC current	DC current
(2)	DC current or AC current	DC current or AC current
(3)	DC current or AC current	AC current
(4)	AC current	AC current or DC current

**

සියලු ම හිමිකම් ඇවිරිණි / முழுப் பதிப்புரிமையுடையது / All Rights Reserved

ශ්‍රී ලංකා විභාග දෙපාර්තමේන්තුව
இலங்கைப் பரீட்சைத் திணைக்களம்
Department of Examinations, Sri Lanka

90 E I, II

අධ්‍යයන පොදු සහතික පත්‍ර (සාමාන්‍ය පෙළ) විභාගය, 2024(2025)
கல்விப் பொதுத் தராதரப் பத்திர (சாதாரண தர)ப் பரீட்சை, 2024(2025)
General Certificate of Education (Ord. Level) Examination, 2024(2025)

නිර්මාණකරණය, විදුලිය හා ඉලෙක්ට්‍රොනික තාක්ෂණවේදය I, II
வடிவமைப்பும் மின் இலத்திரனியல் தொழினுட்பவியலும் I, II
Design, Electrical & Electronic Technology I, II

Design, Electrical & Electronic Technology II

- * Answer five questions including the first question and four other selected questions.
- * Question No.1 carries 20 marks and each of the other questions carry 10 marks.

1. (i) The following figure shows an isometric view of an object.

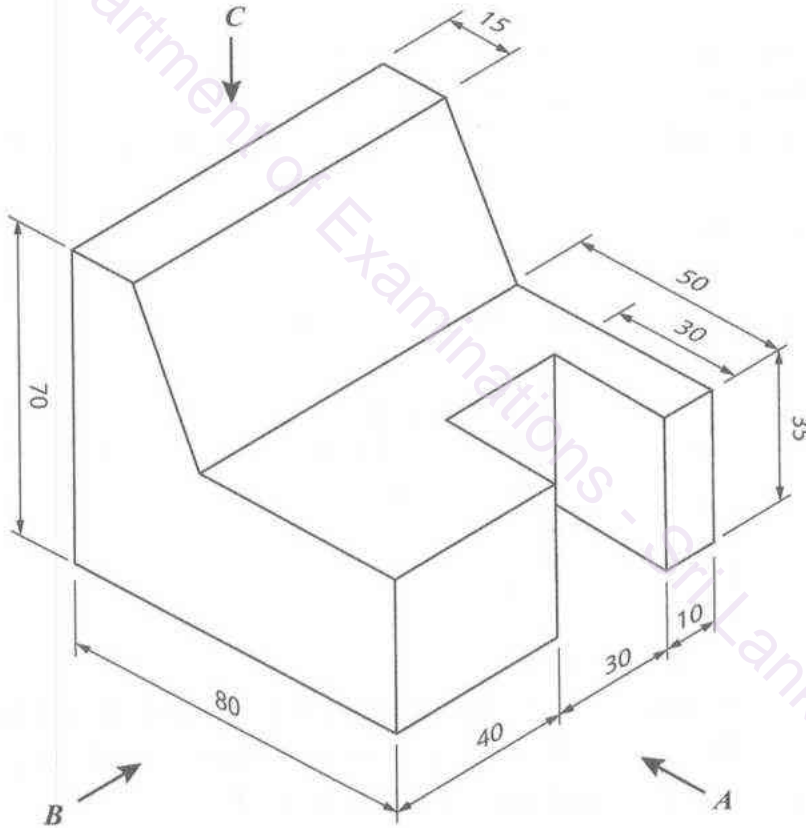

According to the above isometric figure, draw the followings elevations in third angle orthographic projection as per given measurement. The scale to be used is 1:1. (measurements are given in mm)

- (1) Front elevation by looking at arrow **A**
- (2) Side elevation by looking at arrow **B**
- (3) Plan by looking at arrow **C**

- (ii) According to any standard method, draw an ellipse with the major axis 80 mm and the minor axis 50 mm. Construction lines should be clearly shown. Name the relevant method used to construct the ellipse by you.

2. 13 A socket outlet and 2 lamps are included in a domestic electric installation circuit. Two separate sub circuits operate using 1.5 mm^2 cables for socket outlet and 1 mm^2 cables for lamps. These two lamps operate by two switches and in a case of emergency, both lamps must be able to operate with one switch.
- Mention the specifications of the Miniature Circuit Breaker which must be used in socket outlet circuit.
 - Mention specifications of a Miniature Circuit Breaker which must be used in lamp circuit.
 - Name the types of switch which must be used in lamp circuit.
 - Draw the wiring diagram for the lamp circuit using standard symbols.

3. Continuous Oxygen supply must be provided for a fish tank in a house. A 12 V oxygen motor which operates automatically as soon as the main supply is disconnected is used here. Below shows the function of it.

As soon as the main supply is disconnected motor operates by using a switch of 230 V relay. After reconnection of the main supply, the motor must be shutdown by using a push button switch.

Following components are given to assemble a suitable relay circuit for this.

- Normal Open Push button switch (230 V)
 - 230 V Relay (included an open switch and a closed switch in normal state)
 - 12 V Battery
 - 12 V Oxygen motor
- Draw the circuit which operates the relay.
 - Draw the circuit which is operated 12 V oxygen motor.
4. (i) Show using a circuit diagram how to assemble a low voltage Direct Current (DC) supply by using below mention components. (Use full wave rectification)
- 230 V / 0 – 12 V / 500 mA Transformer
 - 1N4007 Diodes
 - 230 V / 500 mA Fuse
 - 1000 μF / 50 V Capacitors
 - 12 V / 200 mA Electric lamp
- What is the RMS (Root Mean Square) voltage given by transformer output?
 - What is the output voltage with capacitor used and without electric lamp?
 - Draw the output wave diagram with electric lamp used.

5. (i) Mention the biasing method of silicon transistor circuit shown in the figure.
- Operation of a transistor is displayed by 3 regions of characteristic curve. Calculate base current (I_B) when a signal is not given to input signal.
 - Mention the regions where the transistor get activate to each voltage levels after giving the signal to the input of the above circuit.
 - Draw the output wave when a signal is given to the input of circuit.

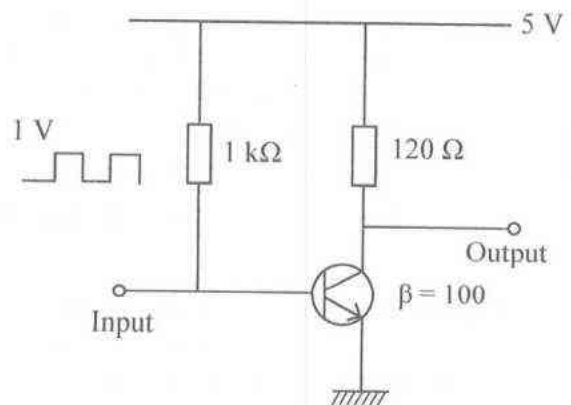

[see page eleven

6. Following circuit diagram illustrates a circuit with a NE555 Linear Integrated Circuit.

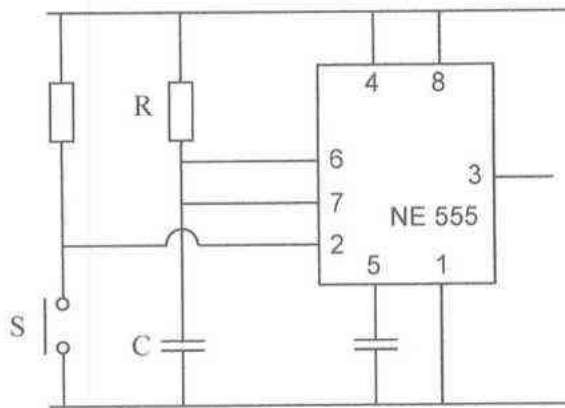

- (i) What is the name of this circuit?
- (ii) Describe a practical usage of this circuit.
- (iii) Draw the wave form of output 3 when 'S' switch is on for an instance.
- (iv) Explain the change occur in output by changing R and C.

7. The following figure illustrates a gate circuit.

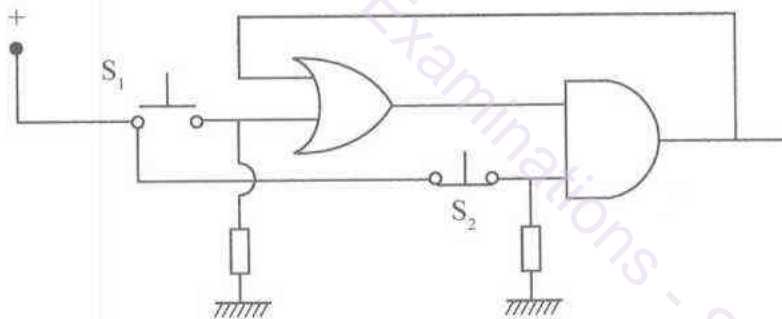

- (i) Write the logic of the output when switch S_1 and switch S_2 is on in the above gate circuit.
- (ii) According to the above (i) operation what is the usage of this circuit?
- (iii) Redraw the circuit with appropriate components to the input to operate 230 V electric lamp by above action.
- (iv) Describe a usage of above (iii) circuit.

(3)

(2)

(1)

Department of Examinations - Sri Lanka