

සියලු ම හිමිකම් ඇවිරිණි / முழுப் பதிப்புரிமையுடையது / All Rights Reserved]

ශ්‍රී ලංකා විභාග දෙපාර්තමේන්තුව ශ්‍රී ලංකා විභාග දෙපාර්තමේන්තුව ශ්‍රී ලංකා විභාග දෙපාර්තමේන්තුව ශ්‍රී ලංකා විභාග දෙපාර්තමේන්තුව ශ්‍රී ලංකා විභාග දෙපාර්තමේන්තුව
இலங்கைப் பரீட்சைத் திணைக்களம் இலங்கைப் பரීட்சைத் திணைக்களம் இலங்கைப் பரීட்சைத் திணைக்களம் இலங்கைப் பரීட்சைத் திணைக்களம் இலங்கைப் பரීட்சைத் திணைக்களம்
Department of Examinations, Sri Lanka Department of Examinations, Sri Lanka Department of Examinations, Sri Lanka Department of Examinations, Sri Lanka Department of Examinations, Sri Lanka
ශ්‍රී ලංකා විභාග දෙපාර්තමේන්තුව ශ්‍රී ලංකා විභාග දෙපාර්තමේන්තුව ශ්‍රී ලංකා විභාග දෙපාර්තමේන්තුව ශ්‍රී ලංකා විභාග දෙපාර්තමේන්තුව ශ්‍රී ලංකා විභාග දෙපාර්තමේන්තුව
இலங்கைப் பரීட்சைத் திணைக்களம் இலங்கைப் பரීட்சைத் திணைக்களம் இலங்கைப் பரීட்சைத் திணைக்களம் இலங்கைப் பரීட்சைத் திணைக்களம் இலங்கைப் பரීட்சைத் திணைக்களம்
Department of Examinations, Sri Lanka Department of Examinations, Sri Lanka Department of Examinations, Sri Lanka Department of Examinations, Sri Lanka Department of Examinations, Sri Lanka

88 E I, II

අධ්‍යයන පොදු සහතික පත්‍ර (සාමාන්‍ය පෙළ) විභාගය, 2024(2025)
கல்விப் பொதுத் தராதரப் பத்திர (சாதாரண தர)ப் பரீட்சை, 2024(2025)
General Certificate of Education (Ord. Level) Examination, 2024(2025)

නිර්මාණකරණය හා ඉදිකිරීම් තාක්ෂණවේදය I, II
வடிவமைப்பும் நிர்மாணத் தொழினுட்பவியலும் I, II
Design and Construction Technology I, II

පැය තුනයි
மூன்று மணித்தியாலம்
Three hours

අමතර කියවීම් කාලය - මිනිත්තු 10 යි
மேலதிக வாசிப்பு நேரம் - 10 நிமிடங்கள்
Additional Reading Time - 10 minutes

Use additional reading time to go through the question paper, select the questions and decide on the questions that you give priority in answering.

Design and Construction Technology I

Instructions:

- * Answer all questions.
- * In each of the questions 1 to 40, pick one of the alternatives (1), (2), (3), (4) which is correct or most appropriate.
- * Mark a cross (X) on the number corresponding to your choice in the answer sheet provided.
- * Further instructions are given on the back of the answer sheet. Follow them carefully.

1. If the sum of the interior angles of three geometrical figures are 180° , 360° and 540° , the geometrical figures matching for them respectively, are
 - (1) triangle, circle and pentagon.
 - (2) triangle, quadrilateral and hexagon.
 - (3) circle, quadrilateral and pentagon.
 - (4) semi circle, triangle and heptagon.
2. Consider the geometrical figure given below which is developed based on a hexagon with same sides.

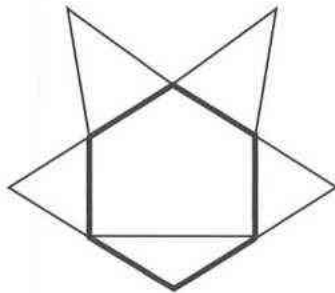

The figure includes

- (1) two equilateral triangles and three isosceles triangles.
 - (2) three equilateral triangles and two isosceles triangles.
 - (3) one equilateral triangle and three isosceles triangles.
 - (4) two scalene triangles and two equilateral triangles.
3. The radius of one circle is 40 mm and the radius of another circle is 30 mm. If these two circles are to be tangent at one point, the length of the line to be drawn equal to the length between the centers of those two circles is
 - (1) must be 40 mm.
 - (2) must be 60 mm.
 - (3) must be 70 mm.
 - (4) must be 80 mm.

4. A geometrical figure in which the construction lines are not shown, is given below.

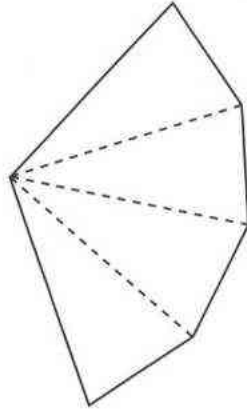

Above geometrical figure shows

- (1) a development of a prism in which the sides of the plan are equal in length.
 - (2) a development of a pyramid in which the sides of the plan are equal in length.
 - (3) a development of a tetrahedron in which the sides of the plan are equal in length.
 - (4) a development of a tetrahedron in which the sides of the plan are not equal in length.
5. What is the correct figure which shows the standard lines when drawn across the center of the circle included in the front view or the side view or the plan of orthogonal projections?

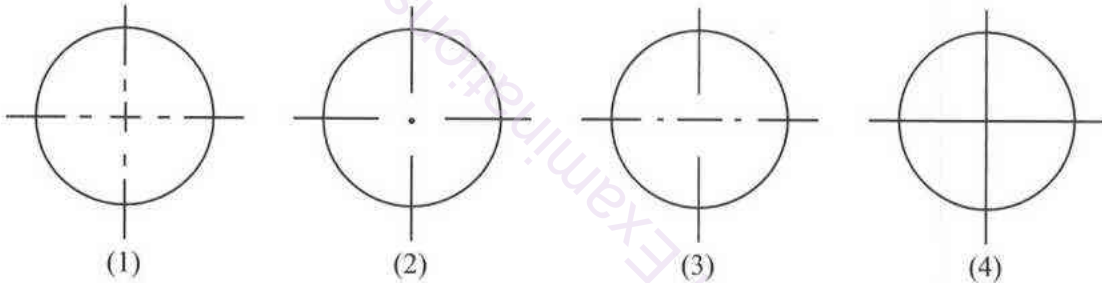

6. Some details of a geometrical figure are given below.

A – Opposite sides are equal.

B – Opposite angles are equal.

C – Though the diagonals are not equal in length, they bisect each other.

According to above details, this figure is

- (1) a rhombus.
- (2) a rhomboid.
- (3) a rectangle.
- (4) a trapezium.

7. Consider the following items.

A – A sheet tin

B – A cardboard box

C – A brick

D – A wooden block

E – A funnel

What are the items which can be developed from given above?

- (1) *A*, *B* and *C* only
 - (2) *A*, *B* and *E* only
 - (3) *A*, *B* and *D* only
 - (4) *B*, *D* and *E* only
8. When piece of paper which has been cut in the shape of an equilateral triangle is divided into two symmetrically, the resultant figure is
- (1) an isosceles triangular shape.
 - (2) a scalene triangular shape.
 - (3) an equilateral triangular shape.
 - (4) a rectangular shape.

9. The factors which influence technicians in transferring towards power tools and equipment than local hand tools and equipments are
- (1) rough state and increase of efficiency.
 - (2) increase of efficiency and accuracy of work.
 - (3) not having standard dimensions and easy purchasing.
 - (4) rough state and good finishing.
10. When constructing a brick wall the distance between the vertical joint of one brick course and the closest vertical joint of next brick course is called as
- (1) the bed joint. (2) the toothing end. (3) the lap length. (4) racking back end.
11. What is the rubble masonry method which can be constructed at low cost and within a short period of time?
- (1) coursed random rubble masonry wall (2) uncoursed random rubble masonry wall
 - (3) coursed square masonry wall (4) gabion wall
12. Select the correct choice which includes the tools and equipments used in fabricating of Aluminium.
- (1) Welding machine, Pop rivet gun (2) Mitre saw, Pop rivet gun
 - (3) Rotary Hammer, Mitre saw (4) Frame saw, Welding machine
13. Select the correct choice that includes the basic properties to be there in constructing structures.
- (1) strength, mass (2) stability, mechanical properties
 - (3) strength, stability (4) strength, plasticity
14. Which of the following is **not** a physical property of materials?
- (1) mass (2) viscosity (3) ductility (4) surface tension
15. Select the correct choice which includes the mechanical properties of materials.
- (1) boiling point, tension and plasticity. (2) tension, compression and viscosity.
 - (3) compression, elasticity and plasticity. (4) viscosity, brittleness and ductility.
16. Consider the following properties.
- A* – Having low compressive strength.
B – Finished with straight edges.
C – Non-uniform cross sectional colour.
D – Burnt as required.
- The most suitable characteristics should be available in bricks which are used to construct brick walls are
- (1) *A* and *B* only. (2) *A* and *C* only. (3) *A* and *D* only. (4) *B* and *D* only.
17. What is compaction of concrete?
- (1) Removing water trapped in the concrete mixture.
 - (2) Removing air trapped in the concrete mixture.
 - (3) Increasing the bond between the concrete and the reinforcement materials.
 - (4) Mixing properly the aggregate materials of the concrete mixture.
18. Light weighted uPVC pipes are manufactured to resilience the ultraviolet rays. Printed information on such a pipe is given in below figure.

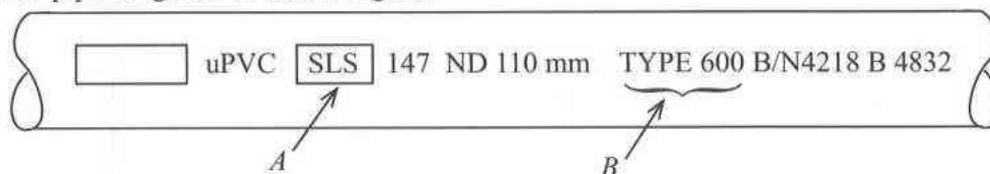

In above, *A* and *B* representing respectively

- (1) the standard number and nominal external diameter.
- (2) the pressure class and nominal external diameter.
- (3) manufacturing batch number and standard number.
- (4) standard number and pressure class.

19. The type of the pipe which is used to drain water with high pressure and high capacity is
(1) Copper pipes. (2) uPVC pipes. (3) GPVC pipes. (4) CPVC pipes.
20. Pipe wrench is an essential instrument when constructing water plumbing systems. Select the option which indicates the correct function of it.
(1) To hold tightly the circular pipes.
(2) To remove burrs from outside and inside of the cut pipe.
(3) To bend PVC pipes to the needed shapes.
(4) To stop water leaking when connecting pipes together.
21. The main factor to be considered in selecting a training institute in Sri Lanka to follow a vocational training course is
(1) be a registered course in the National Youth Services Council.
(2) be a registered course in the Ceylon German Training Technical Institute.
(3) be a registered and accredited course in the Tertiary and Vocational Education Commission.
(4) be a course conducted by a government training institute.
22. A load that **cannot** be considered as alive load acting on a structure is
(1) the furniture in the building.
(2) the people in the building.
(3) the load acting on the building due to rain.
(4) the different items stored.
23. What is the correct statement regarding English Bond method?
(1) Every course is header courses.
(2) Minimum thickness, which can be bound is half a brick.
(3) The lap length of a wall is half a brick.
(4) Use on load bearing walls.
24. The Hinge type to be used to semi-circularly open and shut windows is
(1) Tee Hinges. (2) Parliament Hinges.
(3) Pivot Hinges. (4) Back flap Hinges.
25. After construction it was noticed that the top course of the wall was not levelled and the wall was not vertical. The instrument which should be used to overcome both of these errors is
(1) try square. (2) straight edge.
(3) spirit level. (4) plumb bob with makily.
26. By keeping closed for a day or two, before using a lime mixture for plastering
(1) it increases the plasticity. (2) it increases the elasticity.
(3) it increases the beauty. (4) it increases the strength.
27. The reservoir constructed recently with two arched dam is
(1) Victoria reservoir. (2) Kothmale reservoir.
(3) Maduruoya reservoir. (4) Moragahakanda reservoir.
28. The immature part of a wooden log is
(1) inner skin. (2) outer skin.
(3) sap wood. (4) pith.
29. An example for smooth wood is
(1) Palu. (2) Lunumidella (3) Nadun. (4) Burutha.
30. A wooden joint that withstand the tension and compression is
(1) dovetail joint. (2) mortise joint.
(3) butt joint. (4) halving joint.

31. Consider the following statements on the use of plywood for concrete form work.

- A – It is easy to work with.
- B – It generates a uniform surface of a concrete.
- C – It generates defects in the concrete.
- D – It limits leakages.

Out of the above statements the correct statements are

- (1) A, B and C only. (2) A, B and D only. (3) A, C and D only. (4) B, C and D only.

32.



The defect in timber marked by the arrows in the figure is

- (1) star shake. (2) ring shake. (3) cup shake. (4) heart shake.

33. Corrugated asbestos sheets are used to construct roofs. The materials used to produce asbestos are

- (1) fibre of Asbestos and Portland cement.
- (2) Portland cement and PVC glue.
- (3) Lime and Portland cement.
- (4) Clay and lime.

34. The instrument to be used to draw parallel lines to the side of a planed wood is

- (1) marking gauge. (2) bevel square.
- (3) try square. (4) marking knife.

35. Spokeshave is used in timber industry for

- (1) smoothing. (2) planning after circling wood.
- (3) fitting. (4) rebating.

36. In planning a board, the first side to be planned is

- (1) wider edge. (2) chamfer.
- (3) top wide side. (4) bottom wide side.

37. What is the practiced use of scarf joint in lengthening the wooden parts?

- (1) Making a table drawer. (2) Making a kitchen bench.
- (3) Making window frames. (4) Joining two wall plates together.

38. A mitre joint is used for

- (1) framing pictures. (2) making a door frame.
- (3) making a timber ceiling. (4) making a dining chair.

39. The area of a timber plank having 200 mm width and 5 m length is (thickness of the plank is 25 mm)

- (1) 1 m². (2) 2 m². (3) 3 m². (4) 4 m².

40. Volume of a timber truss which is having the dimensions of 4500 mm length, 200 mm thickness and 250 mm width is

- (1) 0.125 m³. (2) 0.155 m³. (3) 0.225 m³. (4) 0.275 m³.

**

සියලු ම හිමිකම් ඇවිරිණි / முழுப் பதிப்புரிமையுடையது / All Rights Reserved]

ශ්‍රී ලංකා විභාග දෙපාර්තමේන්තුව ශ්‍රී ලංකා විභාග දෙපාර්තමේන්තුව ශ්‍රී ලංකා විභාග දෙපාර්තමේන්තුව ශ්‍රී ලංකා විභාග දෙපාර්තමේන්තුව
இலங்கைப் பரீட்சைத் திணைக்களம் இலங்கைப் பரීட்சைத் திணைக்களம் இலங்கைப் பரීட்சைத் திணைக்களம் இலங்கைப் பரීட்சைத் திணைக்களம்
Department of Examinations, Sri Lanka Department of Examinations, Sri Lanka Department of Examinations, Sri Lanka Department of Examinations, Sri Lanka
இலங்கைப் பரීட்சைத் திணைக்களம் இலங்கைப் பரීட்சைத் திணைக்களம் இலங்கைப் பரීட்சைத் திணைக்களம் இலங்கைப் பரීட்சைத் திணைக்களம்
Department of Examinations, Sri Lanka Department of Examinations, Sri Lanka Department of Examinations, Sri Lanka Department of Examinations, Sri Lanka

88 E I, II

අධ්‍යයන පොදු සහකික පත්‍ර (සාමාන්‍ය පෙළ) විභාගය, 2024(2025)
கல்விப் பொதுத் தராதரப் பத்திர (சாதாரண தர)ப் பரீட்சை, 2024(2025)
General Certificate of Education (Ord. Level) Examination, 2024(2025)

නිර්මාණකරණය හා ඉදිකිරීම් තාක්ෂණවේදය	I, II
வடிவமைப்பும் நிருமாணத் தொழினுட்பவியலும்	I, II
Design and Construction Technology	I, II

Design and Construction Technology II

- * Answer **five** questions including the **first** question and **four** other selected questions.
- * Question No.1 carries **20** marks and each of the other selected questions carry **10** marks each.

1. (i) The following figure shows an isometric view of an object.

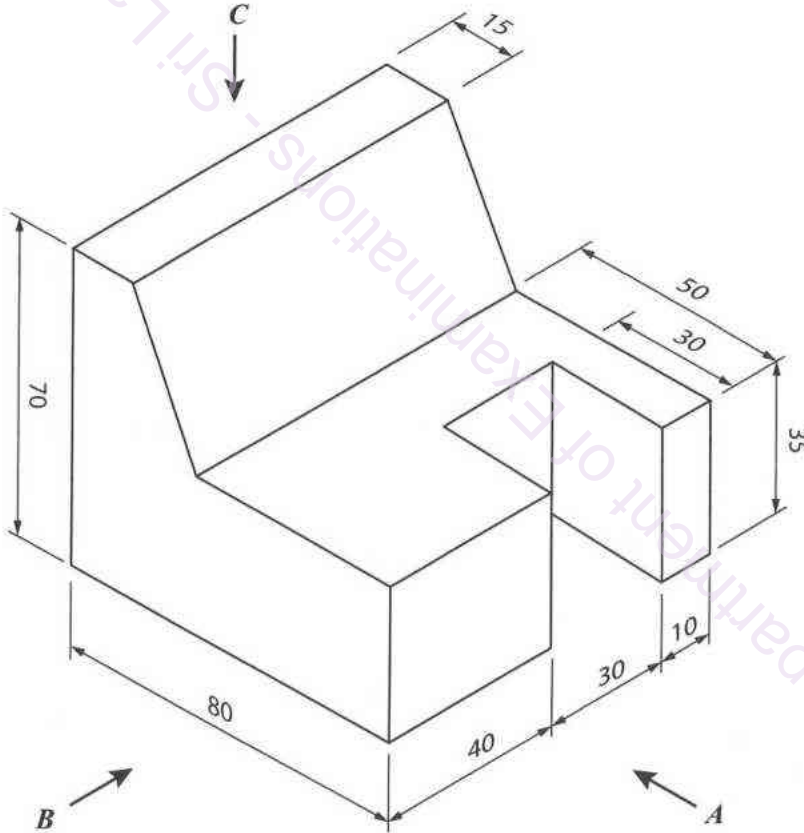

According to the above isometric figure, draw the followings elevations in third angle orthographic projection as per given measurement. The scale to be used is 1:1.
(measurements are given in mm)

- (1) Front elevation by looking at arrow **A**
- (2) Side elevation by looking at arrow **B**
- (3) Plan by looking at arrow **C**

- (ii) According to any standard method, draw an ellipse with the major axis 80 mm and the minor axis 50 mm. Construction lines should be clearly shown. Name the relevant method used to construct the ellipse by you.

2. Different joints are used in timber industry.

- (i) Name the joint type that used to make a wooden door frame.
 - (ii) Describe the process of preparing the joint named in above (i) in order.
 - (iii) A carpenter who was constructing a timber frame was unable to get an entire length of door post by a single timber. The carpenter decides to joint an another part of timber portion to extend the door post adequately. Draw a figure and describe the timber joint that can be used to extend the door post.
3. (i) Which facts are considered in deciding a cross section area of a roof truss that are used according to the load imposed by the roof in a school building?
- (ii) State **two** natural characteristics of timber that should be considered in selecting timber for the roof truss in above (i) and explain briefly that **two** characteristics.
- (iii) After sometime of using the timber selected for the above (i) purpose it can be observed that a crack occurred longitudinally on growth ring of timber. Explain the strategies that are used to avoid the development of this defect.

4.

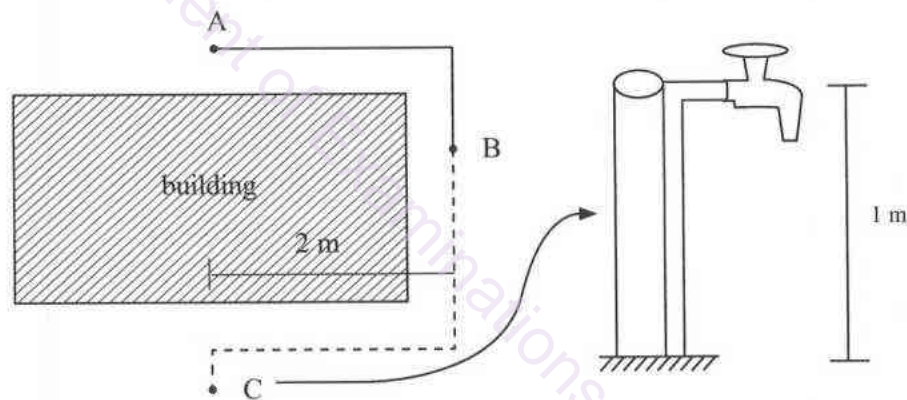

As given in the above figure, there is a water pipe system from A to B which is constructed close to the building. A Bib tap is to be fixed at point C and the system is expected to be extend from B to C in order to supply water for the front area of the building. The Bib tap is to be fixed in a post from 1 m above the ground level.

- (i) Write the necessary PVC water fittings and its required quantity which are needed to construct the water pipe extension from B to C.
- (ii) State **two** problems which can be arise by using galvanize pipes to the water pipe extension from B to C.

5. Following figure shows the way how several workers are working in a site.

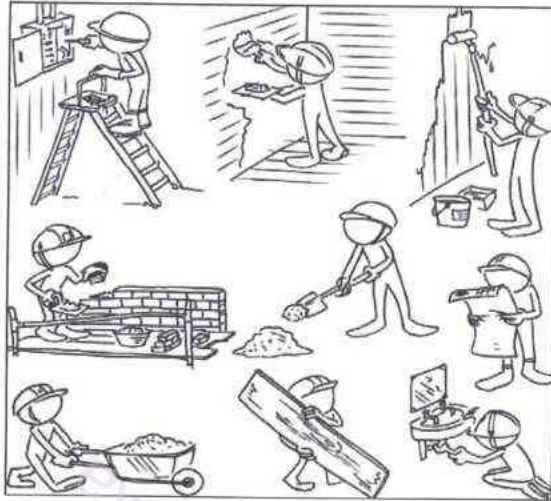

- (i) Name **four** hazards which could be faced by these people according to the figure.
 - (ii) Name **one** personal safety instrument/tool each to be used to prevent from those hazards.
 - (iii) Explain with **three** points how to behave safely in a work site.
6. Bricks are used commonly to construct walls in house construction. Different patterns are used for laying bricks for brick walls.
- (i) Name **two** types of brick bonds and write **two** instances where one bond type used.
 - (ii) Write **three** essential instruments in constructing brick walls.
 - (iii) Draw the front view of **three** consecutive courses for one brick type you mentioned in above (i).
7. The material list, price list, labour cost per day are given below to construct 10 reinforced concrete fence posts of 900 mm height as shown in the figure. For this task, mason and the labour needs two days. Considering the profit is 25%, calculate the selling price of one fence post.

● For cement	Rs. 5000.00
● For sand	Rs. 450.00
● 18 mm rubble	Rs. 500.00
● 6 mm tor steel	Rs. 800.00
● Cost for the mason per day	Rs. 3500.00
● Labour cost per day	Rs. 2500.00
● Transport cost	Rs. 2000.00

